



A Brighter Solution

AMP DISPLAY INC.

SPECIFICATIONS

4.3-in AMOLED MODULE W/ TOUCH

CUSTOMER:	
CUSTOMER PART NO.	
AMP DISPLAY PART NO.	AE-480272KOFET-00H
APPROVED BY:	
DATE:	

APPROVED FOR SPECIFICATIONS

APPROVED FOR SPECIFICATION AND PROTOTYPES

AMP DISPLAY INC

9856 SIXTH STREET RANCHO CUCAMONGA CA 91730
TEL: 909-980-13410 FAX: 909-980-1419
WWW.AMPDISPLAY.COM

RECORD OF REVISION

Revision Date	Page	Contents	Editor
2009/1/16	--	New Release	Edward

1. FEATURES

- (1) Driving Mode : Active Matrix.
- (2) Color Mode : Full Color (16M color)
- (3) Driver IC : HX5116, COG Assembly
- (4) Interface : 8bit serial RGB and 24bit parallel RGB interface
- (5) RoHS Compatible

2. PHYSICAL SPECIFICATIONS

Item	Specifications	unit
Display size	4.3"	inch
Resolution	480 (W) x RGB x 272 (H)	dot
Pixel pitch	0.198 (W) x 0.198 (H)	mm
Active Area	95.0 (W) x 53.8 (H)	mm
Outline Area	103.5 (W) x 67 (H)	mm
Thickness	2.05 (typ.)	mm
Weight	39.6	g

3. ABSOLUTE MAXIMUM RATINGS

Item	Symbol	Min.	Max.	Unit	Note
Logic Supply Voltage	VCC	-0.3	3.6	V	
Analog Supply Voltage	VCI	-0.3	3.6	V	
Operating Temperature	Top	-40	60	°C	
Storage Temperature	Tstg	-40	85	°C	

Note : Maximum ratings are those values beyond which damages to the device may occur. Functional operation should be restricted to the limits in the Electrical Characteristics tables or Pin Description section. Unused outputs must be left open.

4. OPTICAL CHARACTERISTICS

Items	Symbol	Min	Typ.	Max	Unit	Note	
Operating Luminance	L	170	200	230	Cd/m ²	(1)(5)	
Power Consumption	Pon	--	700	950	mW	30% pixels on (1)	
Max. Current	Icc	--	220	302	mA	(1)	
Response Time	Tres	--	--	50	us	(2)	
Color chromaticity	White	Wx	0.26	0.31	0.36	--	(5)
		Wy	0.28	0.33	0.38	--	(5)
	Red	Rx	0.62	0.66	0.70	--	(5)
		Ry	0.30	0.34	0.38	--	(5)
	Green	Gx	0.25	0.29	0.33	--	(5)
		Gy	0.62	0.66	0.70	--	(5)
	Blue	Bx	0.11	0.15	0.19	--	(5)
By		0.12	0.16	0.20	--	(5)	
Viewing Angle	VA	160	170	--	Degree	(3)	
Contrast	CR	5000:1	10000:1	--		(4)	
Operation Lifetime	LTop	20000	--	--	Hrs	(1)(6)	

Note:

Measuring surrounding : Dark room

Surrounding temperature : 25°C

1. Test condition :

a. AR_VDD = 5.2V±0.03V, AR_VSS = -4.8V±0.03V

b. IC Initial Register Setting:

24-bit parallel RGB (DE)
Index_out(0x04); Parameter_out(0x23); //set display mode 24-bit parallel RGB (DE)
Index_out(0x05); Parameter_out(0x82); //set display mode
Index_out(0x07); Parameter_out(0x0F); //set driver capability
Index_out(0x34); Parameter_out(0x18); //set display timing
Index_out(0x35); Parameter_out(0x28); //set display timing
Index_out(0x36); Parameter_out(0x16); //set display timing
Index_out(0x37); Parameter_out(0x01); //set display timing
Index_out(0x02); Parameter_out(0x02); //OTP On
Index_out(0x0A); Parameter_out(0x79); //VGHVGL=±6V
Index_out(0x09); Parameter_out(0x26); //VGAM1OUT=5.0V
Index_out(0x10); Parameter_out(0x07); //set R slop
Index_out(0x11); Parameter_out(0x08); //set G slop

Index_out(0x12); Parameter_out(0x07); //set B slop
Index_out(0x13); Parameter_out(0x00); //set R_0
Index_out(0x14); Parameter_out(0x01); //set R_10
Index_out(0x15); Parameter_out(0x02); //set R_36
Index_out(0x16); Parameter_out(0x01); //set R_80
Index_out(0x17); Parameter_out(0x02); //set R_124
Index_out(0x18); Parameter_out(0x02); //set R_168
Index_out(0x19); Parameter_out(0x03); //set R_212
Index_out(0x1A); Parameter_out(0x06); //set R_255
Index_out(0x1B); Parameter_out(0x00); //set G_0
Index_out(0x1C); Parameter_out(0x02); //set G_10
Index_out(0x1D); Parameter_out(0x00); //set G_36
Index_out(0x1E); Parameter_out(0x01); //set G_80
Index_out(0x1F); Parameter_out(0x02); //set G_124
Index_out(0x20); Parameter_out(0x03); //set G_168
Index_out(0x21); Parameter_out(0x03); //set G_212
Index_out(0x22); Parameter_out(0x05); //set G_255
Index_out(0x23); Parameter_out(0x00); //set B_0
Index_out(0x24); Parameter_out(0x03); //set B_10
Index_out(0x25); Parameter_out(0x06); //set B_36
Index_out(0x26); Parameter_out(0x07); //set B_80
Index_out(0x27); Parameter_out(0x06); //set B_124
Index_out(0x28); Parameter_out(0x05); //set B_168
Index_out(0x29); Parameter_out(0x05); //set B_212
Index_out(0x2A); Parameter_out(0x08); //set B_255
Index_out(0x06); Parameter_out(0x03); //set display on
AR_VDD= +5.2V
AR_VSS= -4.8V

8-bit serial RGB (DE)
Index_out(0x04); Parameter_out(0x21); //set display mode 8-bit serial RGB (DE)
Index_out(0x05); Parameter_out(0x82); //set display mode
Index_out(0x07); Parameter_out(0x0F); //set driver capability
Index_out(0x34); Parameter_out(0x48); //set display timing
Index_out(0x35); Parameter_out(0x78); //set display timing
Index_out(0x36); Parameter_out(0x42); //set display timing
Index_out(0x37); Parameter_out(0x01); //set display timing
Index_out(0x02); Parameter_out(0x02); //OTP On
Index_out(0x0A); Parameter_out(0x79); //VGHVGL=+/-6V
Index_out(0x09); Parameter_out(0x26); //VGAM1OUT=4.85V
Index_out(0x10); Parameter_out(0x07); //set R slop
Index_out(0x11); Parameter_out(0x08); //set G slop
Index_out(0x12); Parameter_out(0x07); //set B slop

Index_out(0x13); Parameter_out(0x00); //set R_0
Index_out(0x14); Parameter_out(0x01); //set R_10
Index_out(0x15); Parameter_out(0x02); //set R_36
Index_out(0x16); Parameter_out(0x01); //set R_80
Index_out(0x17); Parameter_out(0x02); //set R_124
Index_out(0x18); Parameter_out(0x02); //set R_168
Index_out(0x19); Parameter_out(0x03); //set R_212
Index_out(0x1A); Parameter_out(0x06); //set R_255
Index_out(0x1B); Parameter_out(0x00); //set G_0
Index_out(0x1C); Parameter_out(0x02); //set G_10
Index_out(0x1D); Parameter_out(0x00); //set G_36
Index_out(0x1E); Parameter_out(0x01); //set G_80
Index_out(0x1F); Parameter_out(0x02); //set G_124
Index_out(0x20); Parameter_out(0x03); //set G_168
Index_out(0x21); Parameter_out(0x03); //set G_212
Index_out(0x22); Parameter_out(0x05); //set G_255
Index_out(0x23); Parameter_out(0x00); //set G_0
Index_out(0x24); Parameter_out(0x03); //set B_10
Index_out(0x25); Parameter_out(0x06); //set B_36
Index_out(0x26); Parameter_out(0x07); //set B_80
Index_out(0x27); Parameter_out(0x06); //set B_124
Index_out(0x28); Parameter_out(0x05); //set B_168
Index_out(0x29); Parameter_out(0x05); //set B_212
Index_out(0x2A); Parameter_out(0x08); //set B_255
Index_out(0x06); Parameter_out(0x03); //set display on
AR_VDD= +5.2V
AR_VSS= -4.8V

2. Response Time test condition :

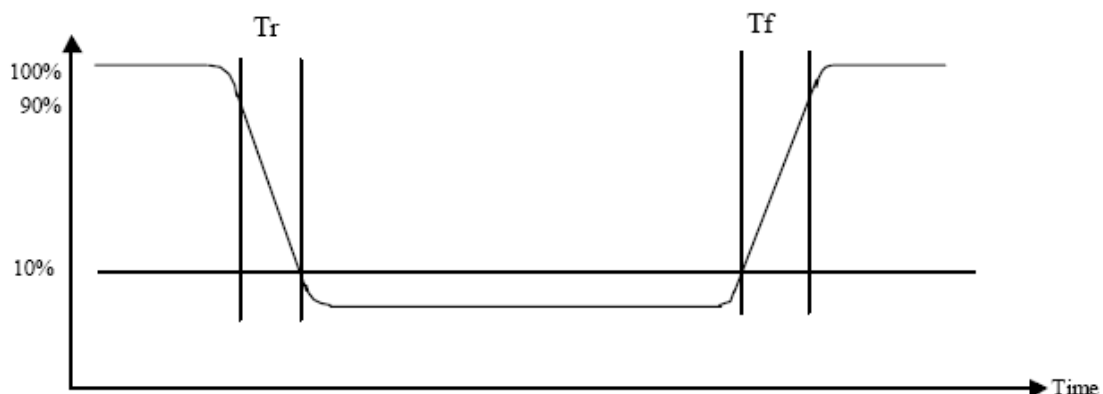

3. Viewing angle test condition :

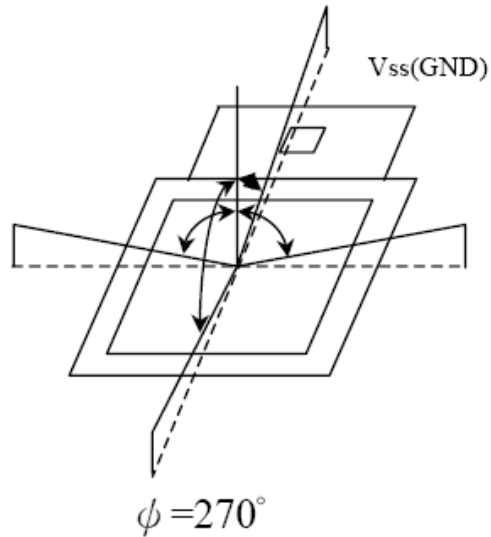

Viewing Angle = CR > 10

4. Contrast :

$$CR = \frac{\text{Luminance with all pixels white}}{\text{Luminance with all pixels black}}$$

5. Optical tester : CA210

6. Brightness of 30% power consumption. Operating Life Time is defined when the luminance has decayed to less than 50% of the initial measured luminance before life test.

5. ELECTRICAL CHARACTERISTICS

5.1 DC Characteristics

(Voltage Referenced to VSS = 0V, VCC = 1.5 to 3.6V, T_A = -20 to 70C)

Item	Symbol	Condition	Min	Typ	Max	Unit
System power supply pins of the logic block	VCC	--	1.5	--	3.6	V
Booster Reference Supply Voltage Range	VCI	--	3.0	--	3.6	V
DDVDH Output Voltage 1	DDVDH	Set CP1X=0	4.9	5.1	5.3	V
DDVDH Output Voltage 2	DDVDH	Set CP1X=1	5.8	6.0	6.2	V
VGAM1OUT Output Voltage 1	VGAM1OUT	Set CP1X=0	4.7	4.8	4.9	V
VGAM1OUT Output Voltage 2	VGAM1OUT	Set CP1X=1	5.7	5.8	5.9	V
Gate driver High Output Voltage	VGH	--	+3	--	+8	V
Gate driver Low Output Voltage	VGL	--	-8	--	-3	V
OLED Diode Refer Voltage	ARREF	--	-8	--	+8	V
Logic High Output Voltage	VOH	I _{out} =400uA	0.8* VCC	--	VCC	V
Logic Low Output Voltage	VOL	I _{out} =400uA	0	--	0.2* VCC	V
Logic High Input Voltage	VIH	--	0.8* VCC	--	VCC	V
Logic Low Input Voltage	VIL	--	0	--	0.2* VCC	V
Logic Input Current	IIL/IIH	No pull up or pull low	-1	--	1	uA
Pull high resistance	RH	Pull up pins	600	900	1200	KΩ
Pull low resistance	RL	Pull low pins	600	900	1200	KΩ
High Output Current	IOH	S1~S107, Vo=4.9V vs. 4V	50	--	--	uA
Low Output Current	IOL	S1~S107, Vo=0.1V vs. 1V	--	--	-50	uA
Output leakage Current	IOZ	--	-1	--	1	uA
Output voltage offset	VOS	S1~S107, Vo=0.1V~ DDVDH-0.1V	--	±10	--	mV

Output voltage deviation	VOD	S1~S107, Vo=0.1V~ DDVDH-0.1V	--	±10	--	mV
Analog standby current	ISTB	VCI=3.0V, Stand by mode	--	--	10	uA
Analog operation current	IVCI	VCI=3.0V, S1~S160 no load	--	--	20	mA
Logic Pins Input Capacitance	CIN	--	--	5	7.5	pF

6. System Diagram

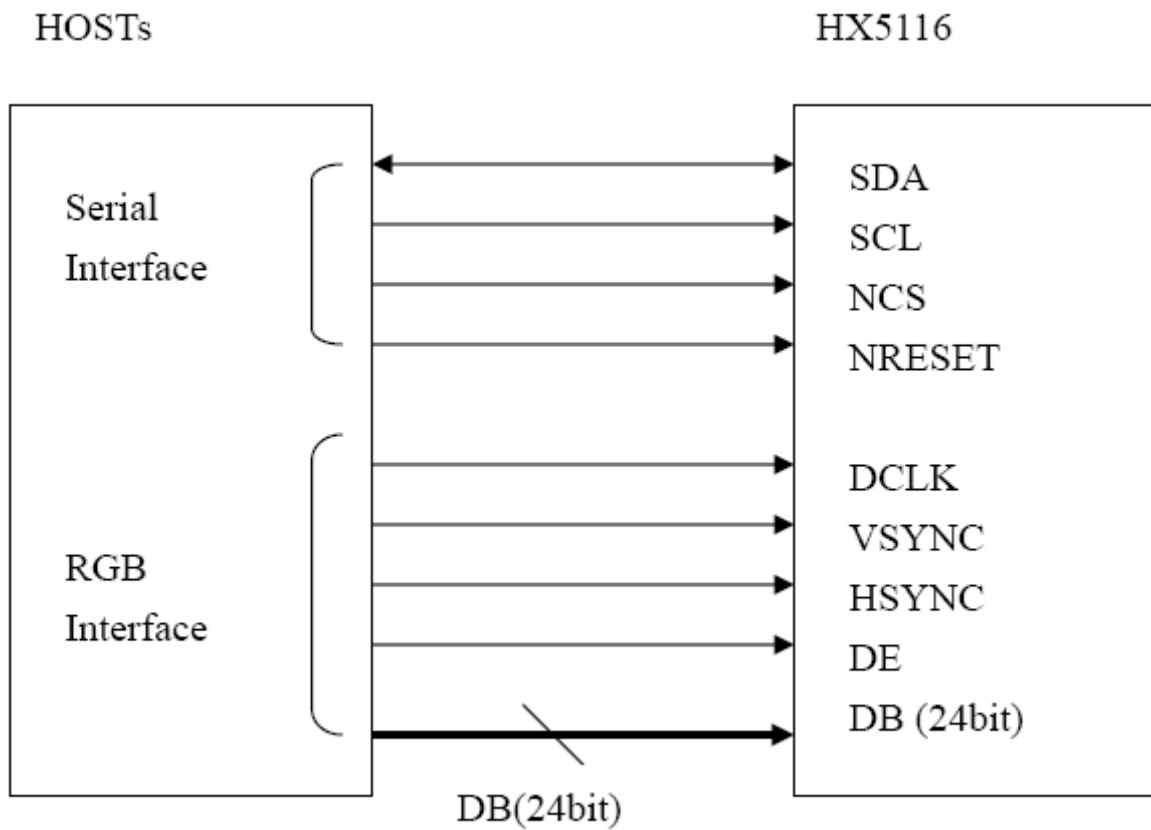

7. INTERFACE PIN ASSIGNMENT

Pin No	Symbol	I/O	Function
1	TP1	I	Touch Panel P1
2	TP2	I	Touch Panel P2
3	TP3	I	Touch Panel P3
4	TP4	I	Touch Panel P4
5	AR_VSS	I	Negative voltage for OLED
6	AR_VSS	I	Negative voltage for OLED
7	TEST1_VS	open	Test pin, it must be open.
8	AR_VDD	I	Positive voltage for OLED
9	AR_VDD	I	Positive voltage for OLED
10	TEST2_VD	open	Test pin, it must be open.
11	ARREF	I/O	Panel refers voltage of the regulator ARREF or external input voltage. (-8V~+8V)
12	VGL	I/O	Low Voltage output of regulator VGL or external input voltage. (-3V~-8V)
13	VGH	I/O	High Voltage output of regulator VGH or external input voltage. (+3V~+8V)
14	LVO	I/O	Negative output voltage of the booster2. (-8.5V)
15	C22N	I/O	Connect to the step-up circuit, capacitors according to the step-up factor. Leave this pin open if the internal step-up circuit is not used.
16	C22P		
17	HVO	I/O	Positive output voltage of the booster2. (8.5V)
18	C21P	I/O	Connect to the step-up circuit, capacitors according to the step-up factor. Leave this pin open if the internal step-up circuit is not used.
19	C21N		
20	C11N	I/O	Connect to the step-up circuit, 4 capacitors according to the step-up factor. Leave this pin open if the internal step-up circuit is not used.
21	C11P		
22	C12N		
23	C12P		
24	PVSS	P	Charge pump ground pin, it must connect to external ground.
25	DDVDH	I/O	Output voltage of the booster1. (5.1V/6.0V)
26	VSSA	P	Analog ground pin. It must connector to external ground.
27	VSSA	P	
28	VCI	P	A power supply for the Analog circuit. (3.0V~3.6V)
29	VCI	P	
30	VGAM1OUT	I/O	Output voltage of the VGAM1OUT regulator and used positive power of source driver. (4.8V / 5.8V)
31	VDDD	I/O	Internal logic voltage input or output pin. VDC_ENB=0, VDDD is output, please connect to 1uF capacitor.

				VDC0	VDDD	Status
				0	1.8V	Normal display
				1	2.5V	OPT program
				VDC-ENB=1, VDDD is input. (Input range = 1.6V~2.75V)		
32	VCC	P	A power supply for the Digital circuit. (1.5V~3.6V)			
33	VSSD	P	Digital ground pin. It must connector to external ground.			
34	NRESET	I	Reset pin. Setting either pin low initializes the LSI. Must be reset after power is supplied. (Normally pull high)			
35	NCS	I	Serial Interface chip enable pin. (Normally pull high)			
36	SCL	I	Serial Interface clock input pin. (Normally pull high)			
37	SDA	I	Serial Interface data line. (Normally pull high)			
38	DE	I	Data enable: When VSYNC+HSYNC+DE mode, DE=H: Data enable, DE=L: Data disable (Black). (Normally pull low)			
39	VSYNC	I	Frame synchronizing signal. If VSPL=0: Active low. If VSPL=1: Active high.			
40	HSYNC	I	Line synchronizing signal. If HSPL=0: Active low. If HSPL=1: Active high.			
41	DCLK	I	Dot clock signal. If DPL=0: Data are input on the rising edge of DOTCLK. If DPL=1: Data are input on the falling edge of DOTCLK.			
42	D27	I	Digital data input. DX0 is LSB and DX7 is MSB. (Normally pull low) 1. If parallel RGB input mode is used, D0X, D1X, and D2X indicate R, G, and B data in turn. 2. If serial RGB or RGBD or CCIR601 or CCIR656 input mode is selected, only D07~D00 are used, and others short to GND. DX7~DX0 has 8-bit width, respectively to compose 16,777,216 color and 256 gray scale of 1 pixel.			
43	D26					
44	D25					
45	D24					
46	D23					
47	D22					
48	D21					
49	D20					
50	D17					
51	D16					
52	D15					
53	D14					
54	D13					
55	D12					
56	D11					

57	D10		
58	D07		
59	D06		
60	D05		
61	D04		
62	D03		
63	D02		
64	D01		
65	D00		
66	TEST3_W	open	Test pin, it must be open.
67	AR_VDD	I	Positive voltage for OLED
68	AR_VDD	I	Positive voltage for OLED
69	AR_VSS	I	Negative voltage for OLED
70	AR_VSS	I	Negative voltage for OLED
71	TEST4_P	open	Test pin, it must be open.

8. TIMING CHARACTERISTICS

8.1. AC Electrical Characteristics

PARAMETER	Symbol	Min.	Typ.	Max.	Unit
HSYNC setup time	T_{hst}	10	-	-	ns
HSYNC hold time	T_{hhd}	10	-	-	ns
VSYNC setup time	T_{vst}	10	-	-	ns
VSYNC hold time	T_{vhd}	10	-	-	ns
Data setup time	T_{dsu}	10	-	-	ns
Data hold time	T_{dhd}	10	-	-	ns
DE setup time	T_{esu}	10	-	-	ns
VSYNC falling to HSYNC falling time on odd field @ RGB mode	T_{HV_O}	-4	0	+4	T_{CPH}
VSYNC falling to HSYNC falling time on even field @ RGB mode	T_{HV_E}	0.4	0.5	0.6	T_H
Source output settling time	T_{ST}	-	3	-	μs
Gate signals settling time (90%)	T_{GL}	-	0.5	-	μs
SW signals settling time (90%)	T_{SW}	-	0.6	-	μs

Clock and Data input waveforms

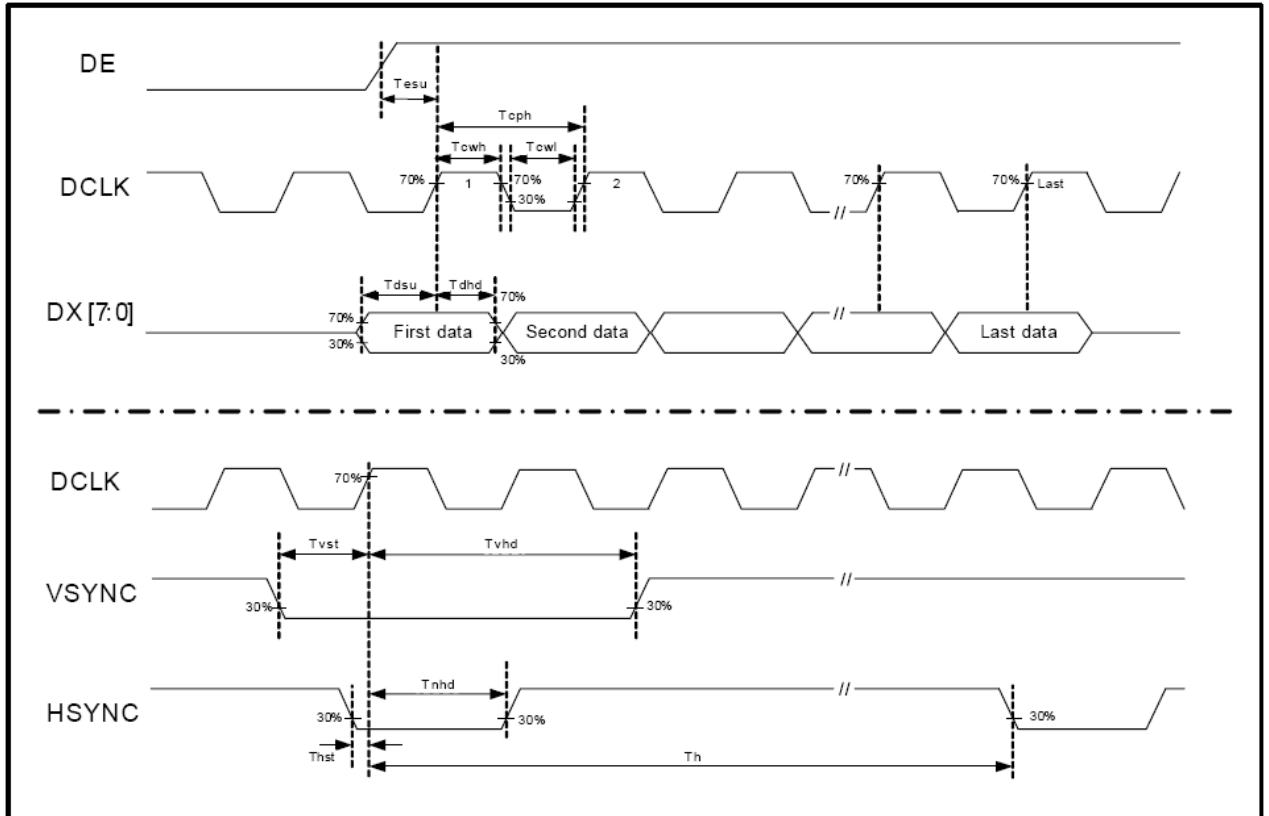

Define the HSYNC to VSYNC timing for RGB mode

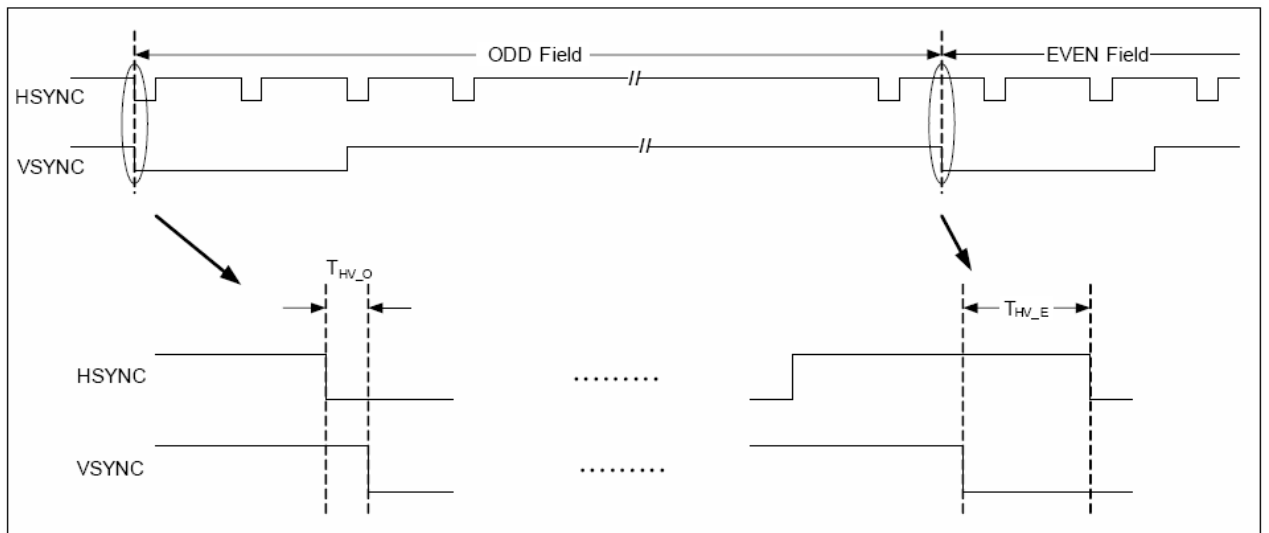

8.2. 480RGB X 272 serial RGB interface

PARAMETER	Symbol	Min.	Typ.	Max.	Unit
DCLK frequency	F_{CPH}	33.3	-	-	MHz
DCLK period	T_{CPH}	-	-	30	ns
DCLK pulse duty	T_{CWH}	40	50	60	%
HSYNC period	T_H	-	1836	-	T_{CPH}
HSYNC pulse width	T_{WH}	5	90	-	T_{CPH}
HSYNC-first horizontal data time	T_{HBP}	274	306	337	T_{CPH}
DE pulse width	T_{EP}	-	1440	-	T_{CPH}
VSYNC pulse width	T_{WV}	1	3	5	T_H
VSYNC-1 st Data input (DE) time	T_{VBP}	4	20	35	T_H
VSYNC period	T_V	302	-	-	T_H

8.3. 480RGB X 272 parallel RGB interface

PARAMETER	Symbol	Min.	Typ.	Max.	Unit
DCLK frequency	F_{CPH}	11.1	-	-	MHz
DCLK period	T_{CPH}	-	-	90	ns
DCLK pulse duty	T_{CWH}	40	50	60	%
HSYNC period	T_H	-	612	-	T_{CPH}
HSYNC pulse width	T_{WH}	5	30	-	T_{CPH}
HSYNC-first horizontal data time	T_{HBP}	70	102	133	T_{CPH}
DE pulse width	T_{EP}	-	480	-	T_{CPH}
VSYNC pulse width	T_{WV}	1	3	5	T_H
VSYNC-1 st Data input (DE) time	T_{VBP}	4	20	35	T_H
VSYNC period	T_V	302	-	-	T_H

Serial RGB Horizontal Data Format

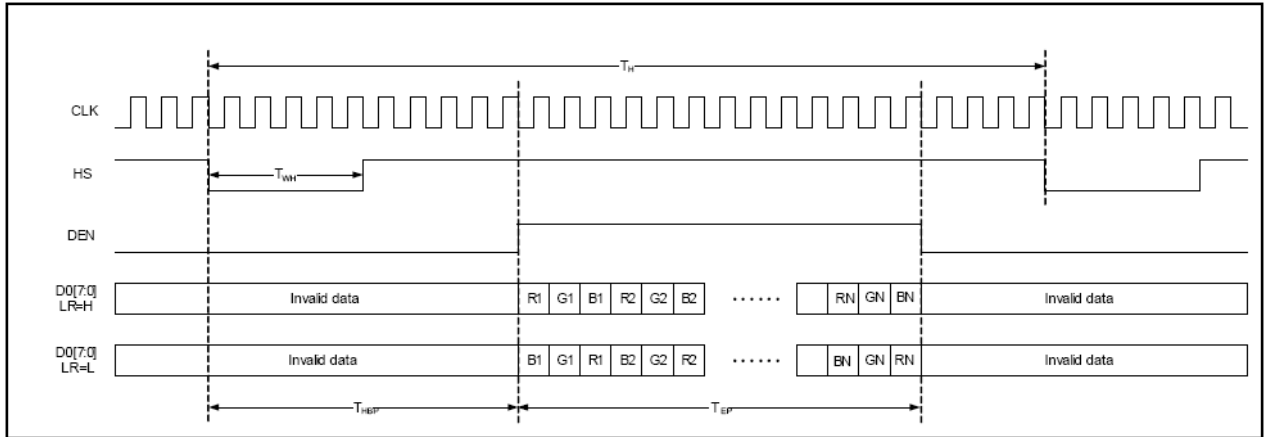

Parallel RGB Horizontal Data Format

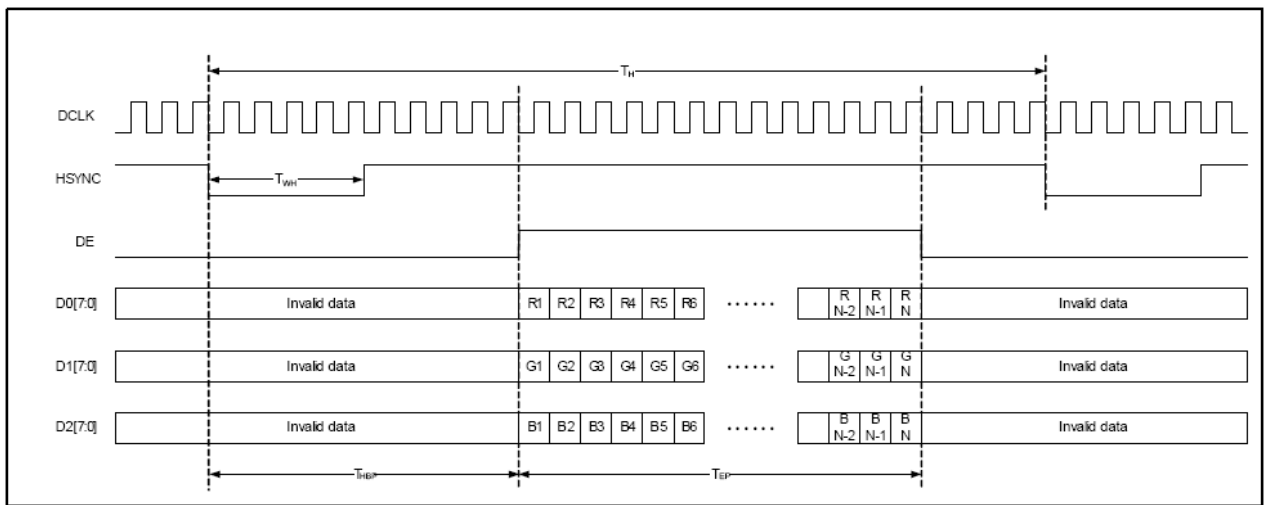

Digital RGB Vertical Data Format

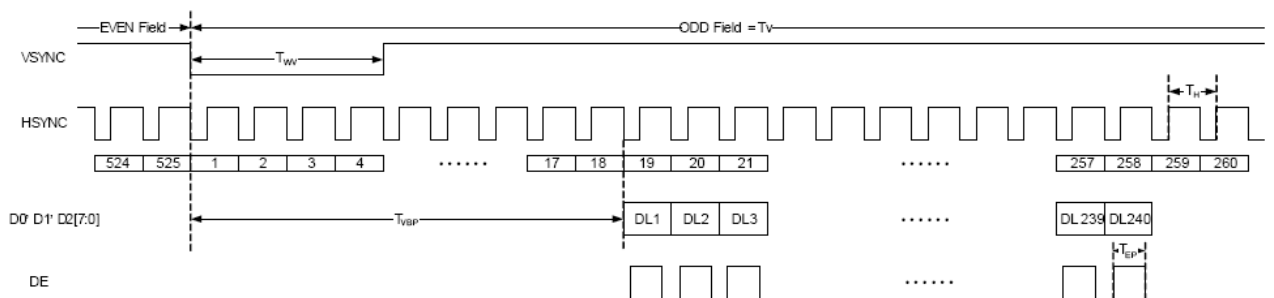

9. DISPLAYED COLOR AND INPUT DATA

	Color & Gray Scale	DATA SIGNAL																	
		R5	R4	R3	R2	R1	R0	G5	G4	G3	G2	G1	G0	B5	B4	B3	B2	B1	B0
Basic Color	Black	0	0	0	0	0	0	0	0	0	0	0	0	0	0	0	0	0	0
	Red(63)	1	1	1	1	1	1	0	0	0	0	0	0	0	0	0	0	0	0
	Green(63)	0	0	0	0	0	0	1	1	1	1	1	1	0	0	0	0	0	0
	Blue(63)	0	0	0	0	0	0	0	0	0	0	0	0	1	1	1	1	1	1
	Cyan	0	0	0	0	0	0	1	1	1	1	1	1	1	1	1	1	1	1
	Magenta	1	1	1	1	1	1	0	0	0	0	0	0	1	1	1	1	1	1
	Yellow	1	1	1	1	1	1	1	1	1	1	1	1	0	0	0	0	0	0
	White	1	1	1	1	1	1	1	1	1	1	1	1	1	1	1	1	1	
Red	Black	0	0	0	0	0	0	0	0	0	0	0	0	0	0	0	0	0	
	Red(1)	0	0	0	0	0	1	0	0	0	0	0	0	0	0	0	0	0	
	Red(2)	0	0	0	0	1	0	0	0	0	0	0	0	0	0	0	0	0	
	:	:	:	:	:	:	:	:	:	:	:	:	:	:	:	:	:	:	
	Red(31)	0	1	1	1	1	1	0	0	0	0	0	0	0	0	0	0	0	
	:	:	:	:	:	:	:	:	:	:	:	:	:	:	:	:	:	:	
	Red(62)	1	1	1	1	1	0	0	0	0	0	0	0	0	0	0	0	0	
Red(63)	1	1	1	1	1	1	0	0	0	0	0	0	0	0	0	0	0		
Green	Black	0	0	0	0	0	0	0	0	0	0	0	0	0	0	0	0	0	
	Green(1)	0	0	0	0	0	0	0	0	0	0	1	0	0	0	0	0	0	
	Green(2)	0	0	0	0	0	0	0	0	0	0	1	0	0	0	0	0	0	
	:	:	:	:	:	:	:	:	:	:	:	:	:	:	:	:	:	:	
	Green(31)	0	0	0	0	0	0	0	1	1	1	1	0	0	0	0	0	0	
	:	:	:	:	:	:	:	:	:	:	:	:	:	:	:	:	:	:	
	Green(62)	0	0	0	0	0	0	1	1	1	1	1	0	0	0	0	0	0	
Green(63)	0	0	0	0	0	0	1	1	1	1	1	1	0	0	0	0	0		
Blue	Black	0	0	0	0	0	0	0	0	0	0	0	0	0	0	0	0	0	
	Blue(1)	0	0	0	0	0	0	0	0	0	0	0	0	0	0	0	0	1	
	Blue(2)	0	0	0	0	0	0	0	0	0	0	0	0	0	0	0	1	0	
	:	:	:	:	:	:	:	:	:	:	:	:	:	:	:	:	:	:	
	Blue(31)	0	0	0	0	0	0	0	0	0	0	0	0	0	1	1	1	1	
	:	:	:	:	:	:	:	:	:	:	:	:	:	:	:	:	:	:	
	Blue(62)	0	0	0	0	0	0	0	0	0	0	0	0	1	1	1	1	0	
Blue(63)	0	0	0	0	0	0	0	0	0	0	0	0	1	1	1	1	1		

10. QUALITY AND RELIABILITY

10.1. Inspection provision

MIL-STD-105E/inspection level II/normal inspection/single sample inspection
AQL: Major 0.65; minor 1.0

10.2. The environmental condition of inspection

The environmental condition and visual inspection shall be conducted as below.

- (1) Ambient temperature : 15~25°C
- (2) Humidity: 25~75 %RH
- (3) External appearance inspection shall be conducted by using a single 20W fluorescent lamp or equivalent illumination.
- (4) Panel visual inspection on the operation condition for cosmetic shall be conducted at the distance 30cm or more between the OLED module and eyes of inspector. And, the viewing angle shall be 90 degree to the front surface of display panel.
Ambient Illumination: 400 ~ 500 Lux for external appearance inspection
Ambient Illumination: 100 ~ 200 Lux for light on inspection

10.3. Classification of defects

Defects are classified two types, major defect and minor defect according to the defect. And, the definition of defects is classified as below.

(1) Major defect

Any defect may result in functional failure, or reduce the usability of product for its purpose. For example, electrical failure, deformation and etc..

(2) Minor defect

A defect that is not to reduce the usability of product for its intended purpose and un-uniformity, dot defect and etc..









The criteria on major and/or minor judgment will be according with the classification of defects.

10.4. Specification for quality check

(1) Electrical/Outline characteristics

Level	Inspection item	Defect	Note
Major	Displaying	Non-displaying	
		Line defects	
		Power consumption	
		Malfunction	
	Panel	Glass cracked	
	FPC / COG	FPC dimension out of specification	
		Other function defects	
Outline dimension	Outline dimension out of specification		
Minor	Displaying	Dim spot \ Bright spot \ dust	Appearance defect
		Non-uniformity	
		Mura	
	Panel	Glass scratch	
		Glass cutting NG	
		Glass chip	
	Polarizer	Polarizer scratch	
		Stains on surface	
		Polarizer bubbles	
	FPC / COG	Damage	
		Foreign material	
	Metal Frame	Appearance	



(2) Test Pattern



Item	Pattern
White	
Black	
Red	
Green	
Blue	
Border	
50% White	
Crosstalk	

(3) Definition of dot defect induced from the panel inside

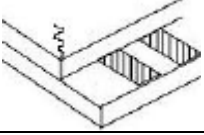
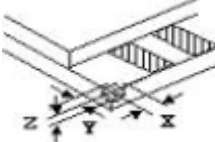
- a) The definition of dot: The size of a defective dot over 1/2 of whole dot is regarded as one defective dot.
- b) Bright dot: Dots appear bright and unchanged in size in which module is displaying under black pattern.
- c) Dark dot: Dots appear dark and unchanged in size in which module is displaying under pure red, green, blue picture.

(4) External appearance defect

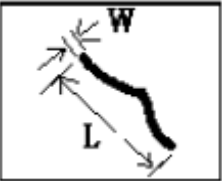
Item	Description	Criterion								
Panel	Glass scratch	0.05<W≤0.1mm, 0.3<L≤2.0mm , N≤3								
	Glass crack	Crack : Propagation crack is not acceptable 								
	Glass chip	Chip on corner	 <table border="1" data-bbox="991 555 1305 674"> <tr> <td>X</td> <td>≤ 1.5 mm</td> </tr> <tr> <td>Y</td> <td>≤ 2.0 mm</td> </tr> <tr> <td>Z</td> <td>≤ t</td> </tr> </table> <p>1.) t = Glass thickness 2.) Chip on the corner extending into the ITO contact is not acceptable 3.) Chip on the corner is not acceptable when it extends into the seal or makes the exposure</p>		X	≤ 1.5 mm	Y	≤ 2.0 mm	Z	≤ t
		X	≤ 1.5 mm							
	Y	≤ 2.0 mm								
Z	≤ t									
	Lead & customer alignment mark can't be damaged.									
Glass burr		y ≤ 0.5mm								
Polarizer	Scratch	Line type in accordance with criteria of "Glass item"								
	Stains on surface	Stains which cannot be moved even when wiped lightly with a soft cloth or similar cleaning are not acceptable								
	Polarizer bubble	Size	Number of pieces permitted							
		φ ≤ 0.3mm	Ignore							
0.3mm < φ ≤ 0.5mm		2								
φ > 0.5mm	0									
Displaying	Power consumption	The module operating current consumption should not go beyond the standard indicated in product specification								
	Pixel size	The tolerance of display pixel dimension should be within ±25% of specification								
	Non-displaying	Not allowable								
	Line defect	Not allowable								

	Black line / White line / Particle / Scratch		$0.05 < W \leq 0.1 \text{ mm}$, $0.3 < L \leq 2.0 \text{ mm}$, $N \leq 3$
	Color	Refer to the spec	
	Luminance	Refer to the spec	
	Dimming spot, Lighting spot, Dust		$0.1 \text{ mm} < D \leq 0.3 \text{ mm}$, $N \leq 3$ $D = (a+b)/2$
	Dot defect	Bright dot	$N \leq 0$
		Dark dot	$N \leq 5$
	Mura	Serious mura not allowable	
FPC / COG	Dimension out of spec.	FPC dimension out of spec	
	Damage	Crack on the FPC/COG deep scratch on the FPC/COG, deep fold on the FPC, deep pressure mark on the FPC/COG or other damage are not acceptable	
	Foreign material	Conductive foreign material sticking to the leads, foreign material and pin-hole between the FPC/COG and the glass are not acceptable.	
Metal Frame	Appearance	Any scratch or contamination outside the viewing can be ignored.	
Dimension	Dimension out of spec.	Refer to the drawing of the spec	

10.5. Reliability Test

No	Test Item	Test Conditions
1	High Temperature Storage	85°C , 240hrs
2	Low Temperature Storage	-40°C ,240hrs
3	High Temperature Operation	60°C , 240hrs
4	Low Temperature Operation	-40°C , 240hrs
5	High Temperature / Humidity Storage	85°C , 85%RH, 240hrs
6	High Temperature / Humidity Operation	60°C , 90%RH, 240hrs
7	Thermal Shock storage	-40°C~85°C (-40°C / 30min; transit/3min; 85°C /30min; transit /3min) 1 cycle : 66min, 100cycles
8	ESD	(1) Contact discharge mode : +/-2KV, 3 times/FPC pin (2) Air discharge mode : +/-8kV, 10 times/central area
9	Packing Test	Drop 1 corner, 3 sides, 6 faces, 1 time for each; Height : follow ISTA standard. Frequency : 5~50Hz, 0.5G Scan rate : 1 oct/min Time : 2 hrs/axis Test axis : X, Y, Z

Test and measurement conditions

- All measurements shall not be started until the specimens attain to temperature stability.
- The degradation of Polarizer is ignored for item 1, 5 & 6.
- The test pattern at operation condition is 30%P.C. alternating pictures.

Evaluation Criteria

- No damage to glass or encapsulation
- No drastic change to display
- Defects / Mura follow product specification
- Luminance : Within +/- 50% of initial value
- Current consumption : within +/- 50% of initial value

10.6. Other

AMIPRE will provide one year warrantee for all products and three months warrantee for all repairing products.

11. OUTLINE DIMENSION

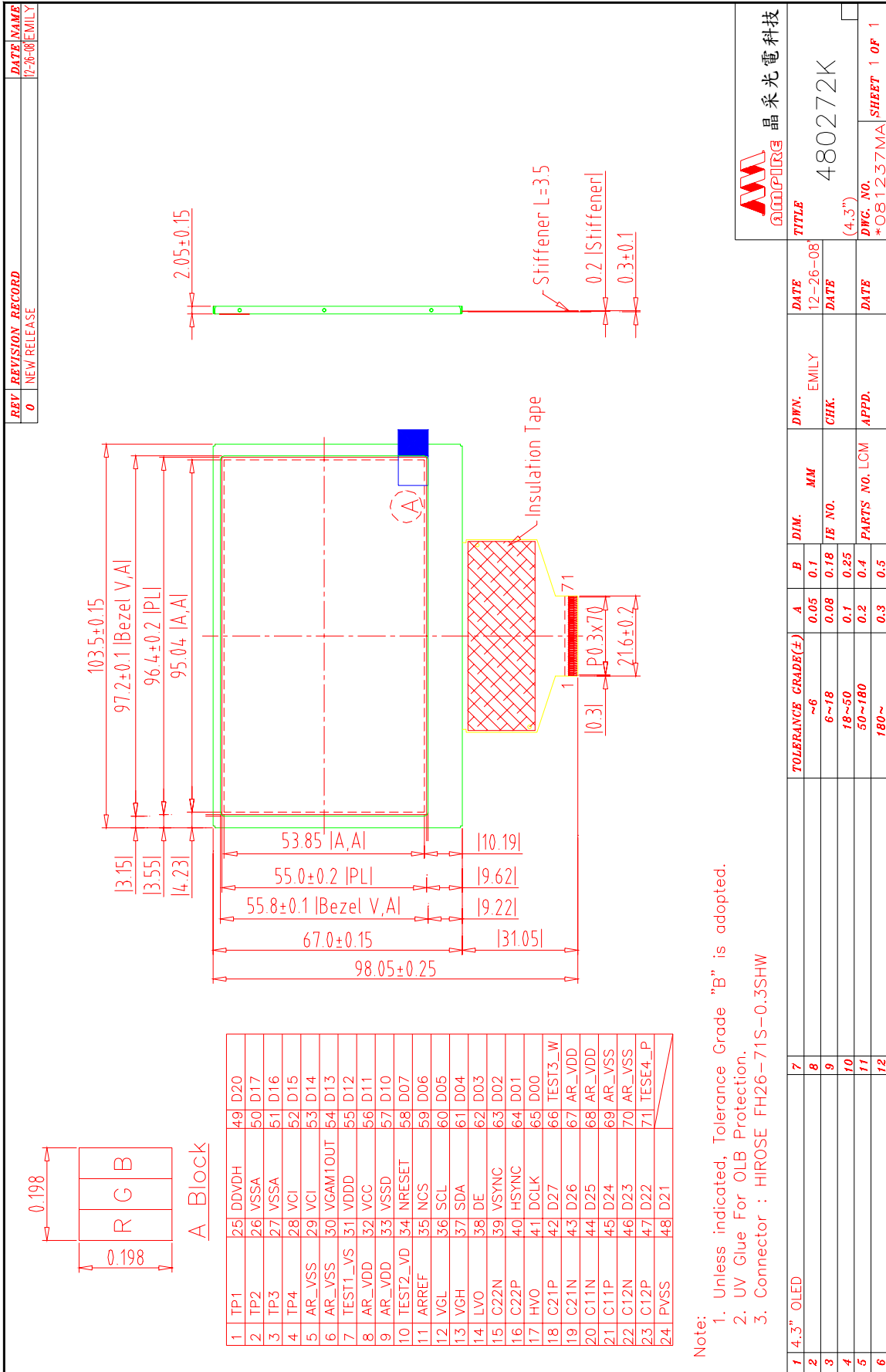

Note:

1. Unless indicated, Tolerance Grade "B" is adopted.
2. UV Glue For OLB Protection.
3. Connector : HIROSE FH26-71S-0.3SHW