



晶采光電科技股份有限公司
AMPIRE CO., LTD.

SPECIFICATIONS FOR LCD MODULE

CUSTOMER	
CUSTOMER PART NO.	
AMPIRE PART NO.	AG-640480C2FTCW
APPROVED BY	
DATE	

AMPIRE CO., LTD.

**TOWER A, 4F, No.114, Sec. 1, HSIN-TAI 5th RD., HIS-CHIH,
TAIPEI HSIEN, TAIWAN(R.O.C.)**

台北縣汐止鎮新台五路一段114號4樓(東方科學園區A棟)

TEL:886-2-26967269, FAX:886-2-26967196 or 886-2-26967270

APPROVED BY	CHECKED BY	ORGANIZED BY

RECORD OF REVISION

Revision Date	Page	Contents
2004/12/22	-	New Release

1. GENERAL SPECIFICATIONS

Item	Contents
Display Contents[pixels]	640(W)×480(H)
Dimensional Outline[mm]	205.5(W)×141.0(H)×7.0 max(D)
Display mode	Transmissive Type (Viewing Direction 6 o'clock)
Circuits	X-Driver, Y-Driver
Interface	Data(UD ₀ ~UD ₃ , LD ₀ ~LD ₃), SCP, FP, LP, DISP

2. ABSOLUTE MAXIMUM RATING

(1) ELECTRICAL ABSOLUTE RATINGS

ITEM	SYMBOL	MIN	MAX	UNIT	NOTE
Power Supply for Logic	V _{DD} -V _{SS}	-0.3	6.5	V	
Input Voltage	V _{EE}	0	27	V	
Static Electricity	-	-	-	-	Note 1

Note 1 LCM should be grounded during handling LCM.

(2) ENVIRONMENTAL ABSOLUTE MAXIMUM RATINGS

ITEM	NORMAL TEMP.			
	OPERATING		STORAGE	
	MIN	MAX	MIN	MAX
Ambient Temperature	0	50	-20	70
Humidity (without Condensation)	Note 2,4		Note 3,5	

Note 2 Ta≤50°C:85%RH max

Ta>50°C:Absolute humidity must be lower than the humidity of 85%RH at 50°C

Note 3 Ta at -20°C will be < 48hrs at 70°C will be < 120hrs

Note 4 Background color changes slightly depending on ambient temperature. This phenomenon is reversible.

Note 5 Ta≤70°C:75RH max

Ta>70°C:absolute humidity must be lower than the humidity of 75%RH at 70°C

3. ELECTRICAL SPECIFICATION (Condition : Ta=25°C)

Item	Symbol	Conditions	Specifications			Unit
			min	typ	max	
Supply Voltage	V _{DD}	-	3.0	3.3	3.6	V
		-	4.75	5.0	5.25	
	V _{EE}	-	21	22.5	24	
Input Voltage (Data,SCP,LP,FP)	V _{IH}	V _{DD} =5V	0.8 V _{DD}	V _{DD}	-	V
	V _{IL}		-	V _{SS}	0.2V _{DD}	
Power Supply Current for LCM (Typical case)	I _{DD}	VDD=5.0V VEE-VDD=22.5V	-	3.0	6.0	mA
	I _{EE}	FLM=70Hz	-	15	30	
Power Supply Current for CCFL B.L.	I _{CCFL}	Vin=10.4V (TDK) CXA-L10L	-	5	-	mA

Note(3) : Life time of backlight will change according to the FL input current.

Note(4) : FL Starting Voltage should be 1400 Vo-p min..

4. CCFL B/L ELECTRICAL SPECIFICATION (Condition : Ta=25°C)

Item	Symbol	Conditions	Specifications			Unit
			min	typ	max	
Lamp Voltage	V _L	-	--	350	--	Vrms
Lamp Current	I _L	V _L =350Vrms	4	5	6	mArms
Lamp Power consumption	P _L	(note 1)	-	1.75	-	W
Lamp Frequency	F _L		--	35	--	KHz
Lamp Life time	L _L	At I _L = 5mArms (note 2)	10000	--	--	hrs

(Note 1) Power consumption exclude inverter loss

(Note 2) Lamp life time : The final brightness is at 50% of original brightness.

4. MECHANICAL SPECIFICATION

(1)Product No.	AG-640480C1FTCW	
(2)Module Size	205.5(W) × 141.0(V) × 7.0 max(D)	
(3)Dot Size	0.21(W)mm × 0.21(H)mm	
(4)Dot Pitch	0.23(W)mm × 0.23(H)mm	
(5)Number of Dots	640(W) × 480(H)Dots	
(6)Duty	1/240 Dual Scan	
(7)Bias	1/13	
(8)LCD Display Mode	STN:	<input type="checkbox"/> Gray Mode <input type="checkbox"/> Yellow Mode <input type="checkbox"/> Blue Mode
	FSTN:	<input type="checkbox"/> Black and White (Normally White/Positive Image) <input checked="" type="checkbox"/> Black and White (Normally Black/Negative Image)
	Rear Polarizer :	Reflective <input type="checkbox"/> Transflective <input checked="" type="checkbox"/> Transmissive <input type="checkbox"/> Transflective(High Transmissive)
(9)Viewing Direction	<input checked="" type="checkbox"/> 6 O'clock <input type="checkbox"/> 12 O'clock <input type="checkbox"/> 3 O'clock	
(10)Backlight	<input type="checkbox"/> W/O <input checked="" type="checkbox"/> CCFL <input type="checkbox"/> EL <input type="checkbox"/> LED	
(11)Controller	-	
(12)DC/DC Converter	-	
(13)Data connector	-	
(14)CCFL connector	WTA-M10L	
(15)Inverter	-	
(16)Weight	(310) g	

5. OPTICAL SPECIFICATIONS

ITEM	SYMBOL	CONDITION	MIN.	TYP.	MAX.	UNIT	NOTE
Contrast	K	25°C	7.0	10.0	-	-	6
Response Time	Tr	0°C	440	550	820	ms	7
		25°C	180	234	350		
		50°C	90	110	165		
	Tf	0°C	200	250	375		
		25°C	90	110	165		
		50°C	75	95	140		
Viewing angle range	θf	25°C	-	50	-	Degree	8
	θb		-	26	-		
	θr		-	45	-		
	θl		-	45	-		
Frame frequency	Fr	25°C	-	70	-	Hz	
Colour	x	25°C	-	0.31	-	-	
	y		-	0.34	-	-	
Luminance	L	25°C Vin=10.4V IL=5mA (TDK) CXA-L10L All dots ON	70.0	85.5	-	cd/m²	9
		All dots OFF	--	13.3	20.0	cd/m²	

[Note 6] Definition of Operation Voltage (V_{EE})

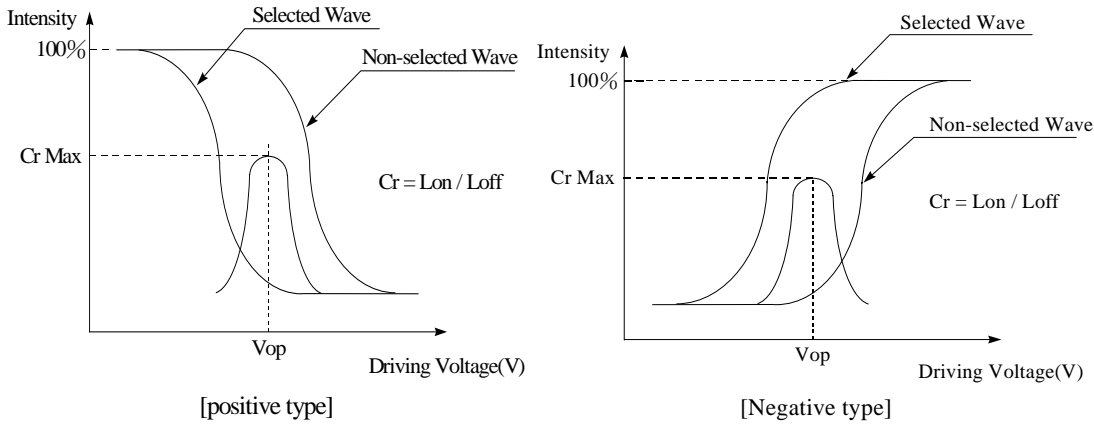

[Note 7] Definition of Response Time (T_r , T_f)

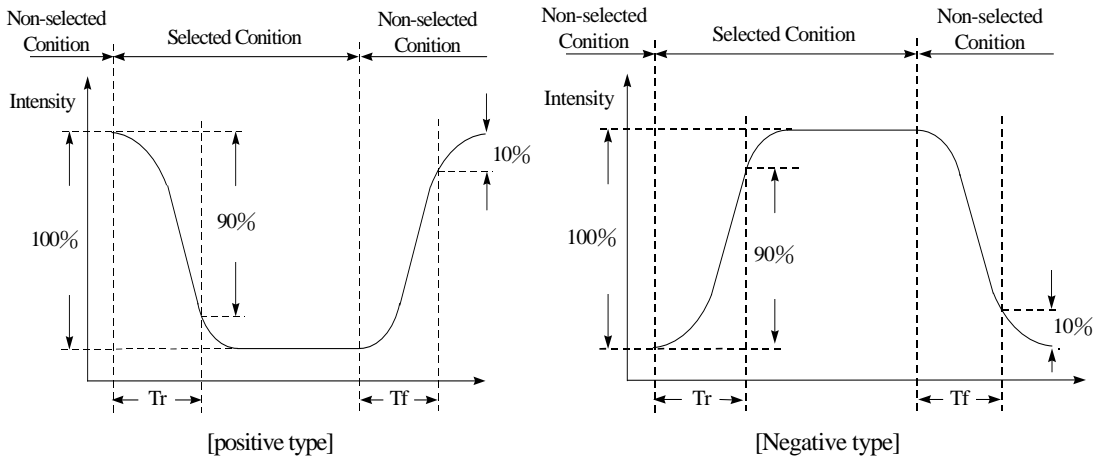

Conditions :

Operating Voltage : V_{LCD}
 Frame Frequency : 64 HZ

Viewing Angle(θ , ϕ) : 0° , 0°
 Driving Waveform : 1/N duty , 1/a bias

[Note 8] Definition of viewing angle($CR \geq 2$)

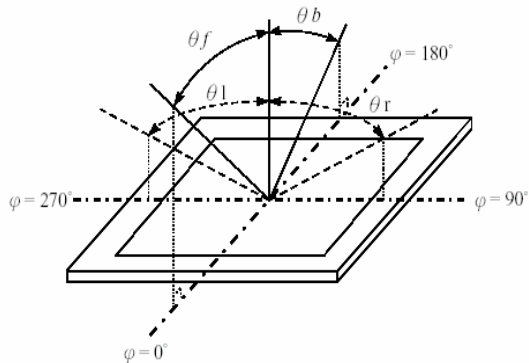

[Note 9] Definition of measuring points

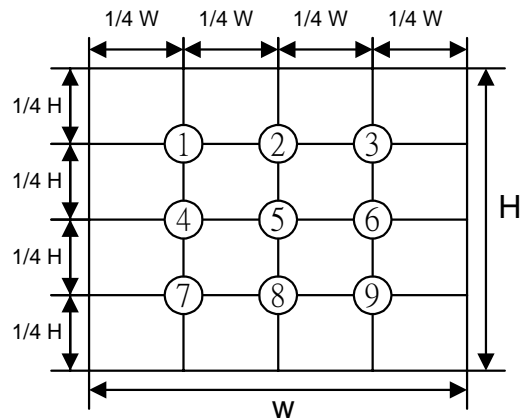

6. INTERFACES

6.1 Interface Pin Assignment

LCD Connector : MOLEX 53261-1590

Pin No.	Signal	Function
1	FLM	Frame Pulse Scan start-up signal
2	CL1(LP)	Latch Pulse in one line
3	CL2(SCP)	Shift Clock Pulse for X-Drivers
4	/DISP	Sequence Signal of Power Supply("L":OFF)
5	VDD	Power Supply for Logic(+5V)
6	VSS	Ground(0 V)
7	VEE	Power Supply for Contrast Control
8	UD0	Data Input for Upper Screen
9	UD1	Data Input for Upper Screen
10	UD2	Data Input for Upper Screen
11	UD3	Data Input for Upper Screen
12	LD0	Data Input for Lower Screen
13	LD1	Data Input for Lower Screen
14	LD2	Data Input for Lower Screen
15	LD3	Data Input for Lower Screen

**Mating Connector : MOLEX 51021-1500 (HOUSING) x 1 +
MOLEX 50058-8000(TERMINAL) x 15**

6.2 CCFL B/L Pin Assignment

FL Connector MITSUMI : M63-M83-04

Pin No.	Signal	Function
1	HV	Power Supply for FL(Hot) High Voltage Line
2	NC	No Connection
3	NC	No Connection
4	GND	Power Supply for FL(Ground) Ground Line

Mating Connector : MITSUMI : M63M83

M60-04-30-114P(MITSUMI)

M60-04-30-134P(MITSUMI)

M61M73-04(MITSUMI)

7. BLOCK DIAGRAM

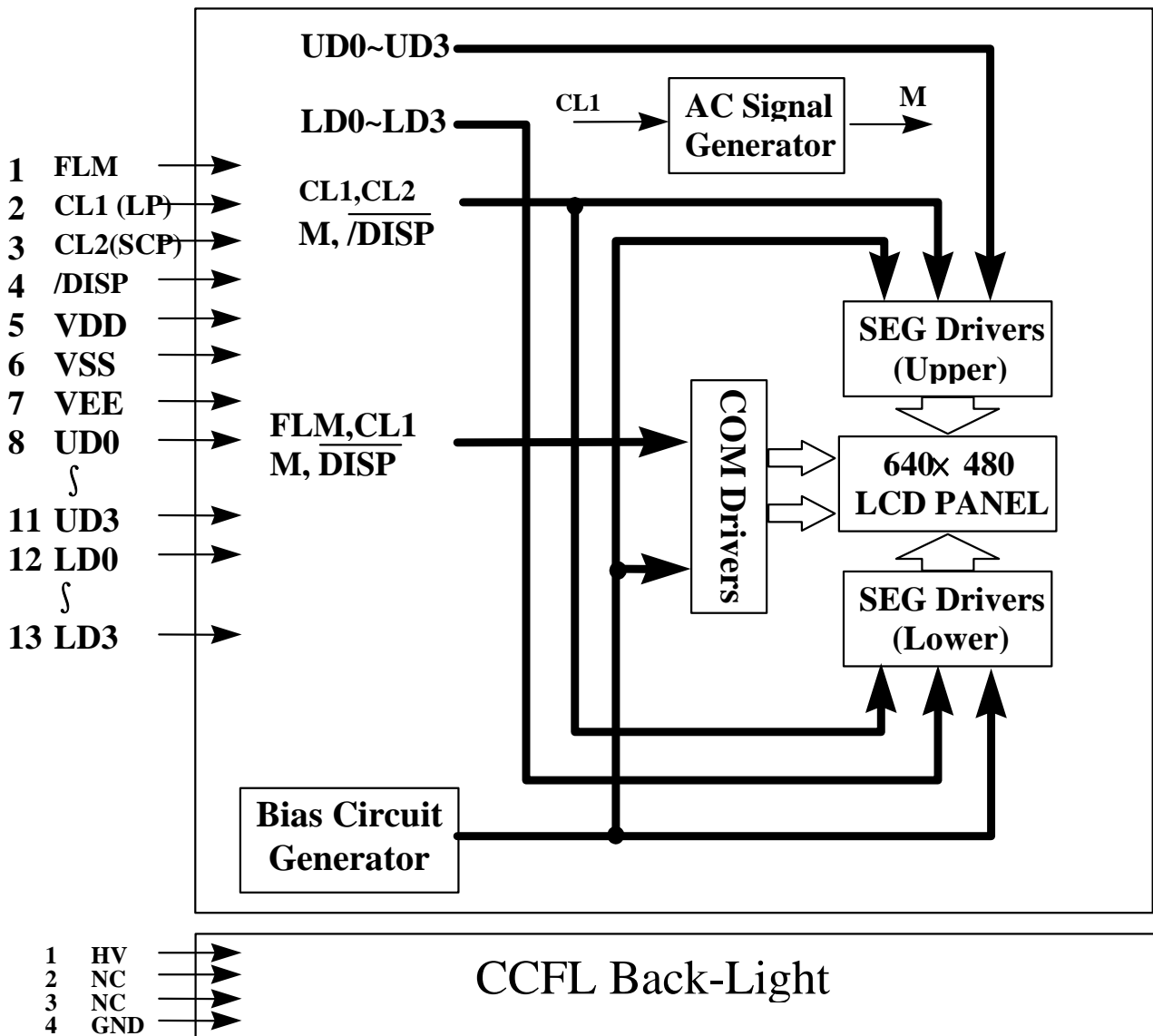

8. POWER SUPPLY

LCM

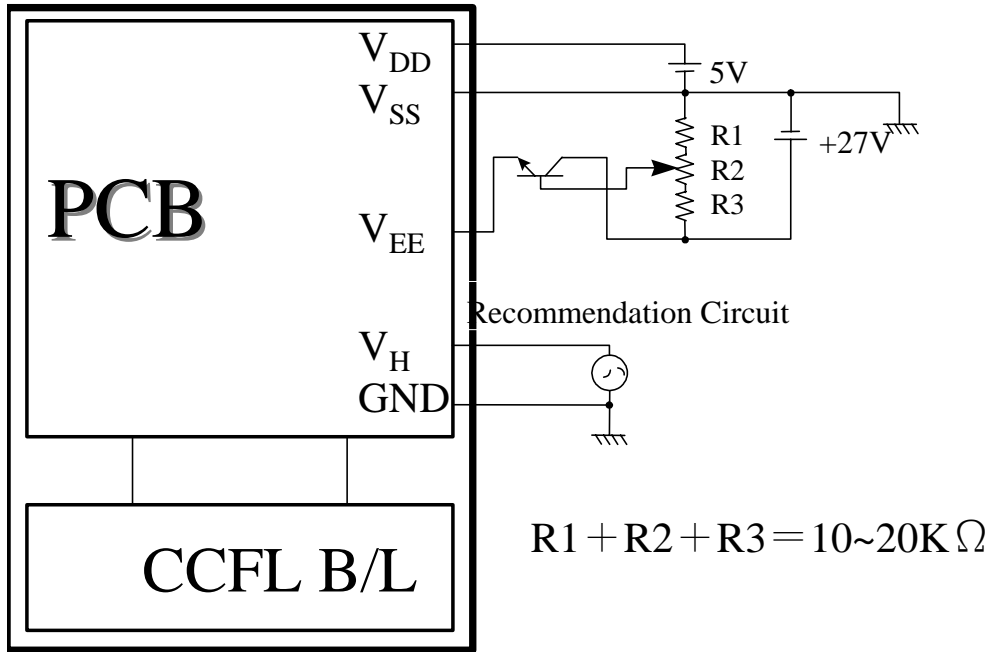

9. TIMING CHARACTERISTICS

9-1. Interface timing:

@VDD=2.5~5.5V

ITEM	SYMBOL	MIN.	TYP.	MAX.	UNIT
Shift Clock Period	t_{cp}	152	—	—	ns
"CL2" PULSE WIDTH	t_w	65	—	—	ns
CLOCK RISE, FALL TIME	t_r, t_f	—	—	50	ns
DATA SETUP TIME	t_{dsu}	50	—	—	ns
DATA HOLD TIME	t_{dhd}	40	—	—	ns
"CL2" → "CL1" FALL TIME	t_{lsu}	65	—	—	ns
"CL1" → "CL2" FALL TIME	t_{lc}	65	—	—	ns
"FLM" SETUP TIME	t_{setup}	100	—	—	ns
"FLM" HOLD TIME	t_{hold}	100	— <td —	ns	
"CL1" PULSE WIDTH	t_{wc}	65	—	—	ns

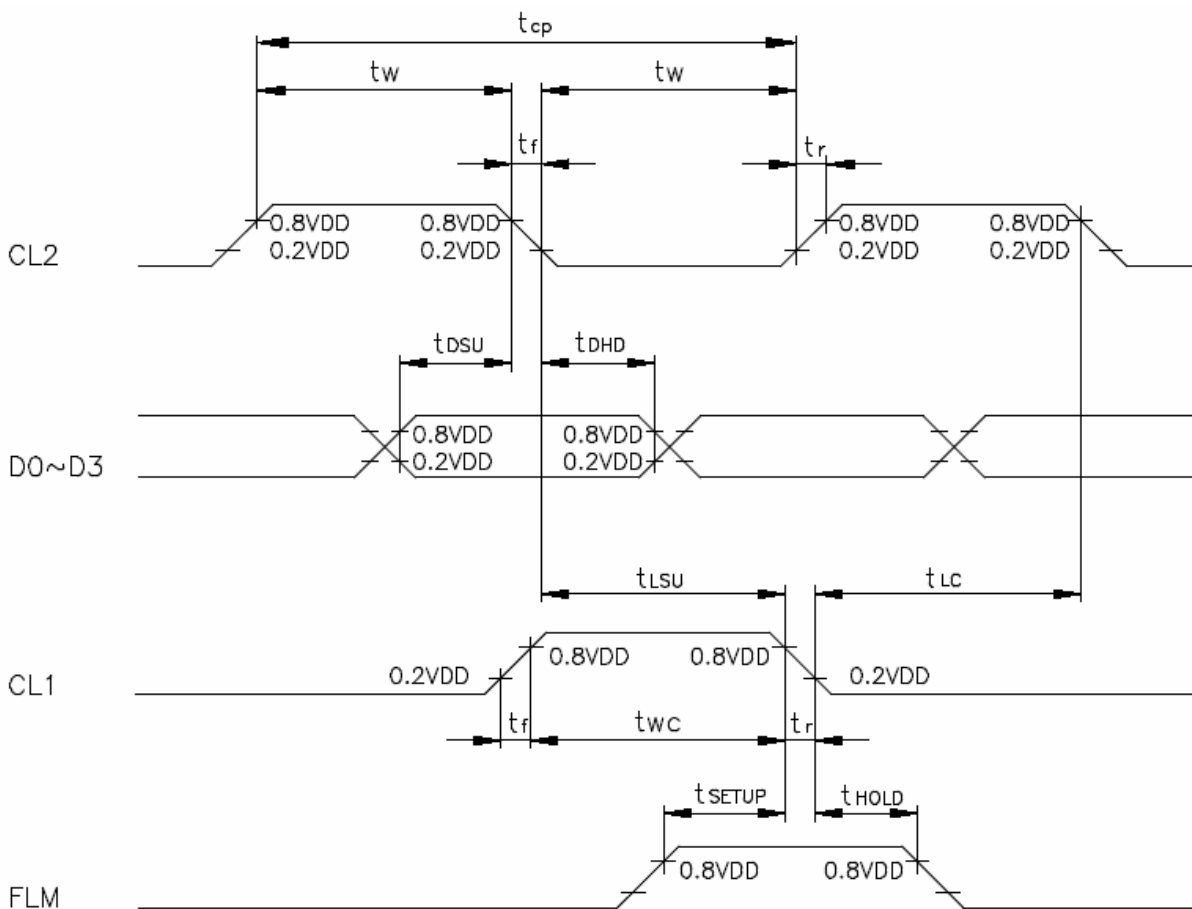

10. DISPLAY PATTERN

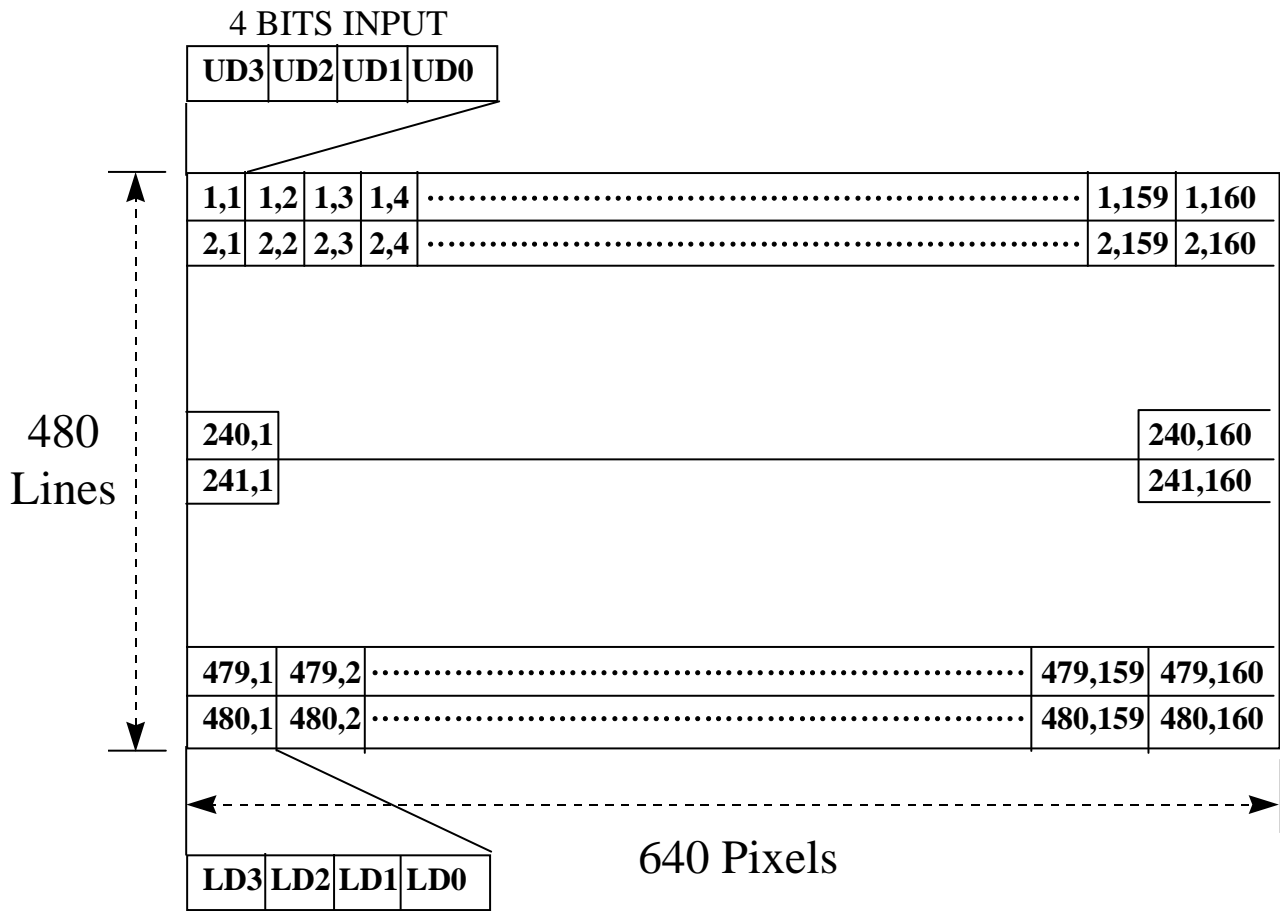

11. RELIABILITY TEST

No	ITEM	Conditions		Note
1	HIGH TEMP. Operation	50°C	120 HR	
2	HIGH TEMP. Storage	70°C	120 HR	
3	LOW TEMP. Operation	0°C	120 HR	
4	LOW TEMP. Storage	-20°C	120 HR	
5	HIGH TEMP/HUMID Storage	50°C 90% RH	120 HR	
6	THERMAL SHOCK	-20°C,30 min 60°C,30 min	10 cycle	
7	SHOCK	70G , 11ms Dir-±x , y , z	3 time/dir	

Definitions of life end point

- (1) Current consumption is more than specified value
- (2) Function of the module is not maintained
- (3) There is visible degradation of appearance and display quality
- (4) Contrast ratio is less than 50 % of specified value
- (5) Brightness is less than 50 % of specified minimum valued

12. APPEARANCE CHECK

CONDITION OF APPEARANCE CHECK :

- (1) Specimen shall be checked by eyes in distance of 30cm under 40w fluorescence lamp.
- (2) Checking direction shall be in 45 degree from perpendicular line of specimen surface.

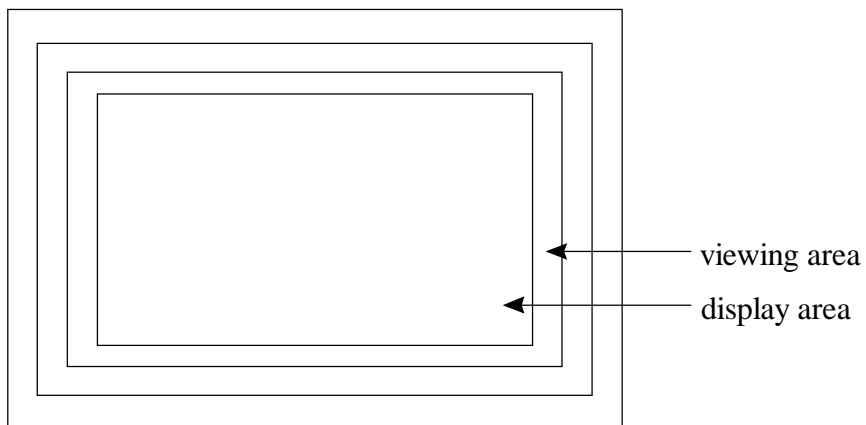

13. HANDLING PRECAUTIONS

- (1) Treat polarizer very carefully since it is easy to be damaged.
- (2) When cleaning the display surface, use soft cloth (e.g. wiper) with a solvent (recommended below) and wipe lightly.

- ethyl alcohol
- iso-propanol

Do not wipe the display surface with dry or hard materials that will damage the polarizer surface.

Do not use the following solvents :

- water
- ketone
- aromatics

- (3) Direct current causes electro-chemical reaction with remarkable degradation of the display quality. Give careful consideration to prevent direct current at ON/OFF timing and during operation.
- (4) Avoid strong shock and drop from a height.
- (5) To prevent LCD panels from degradation, do not operate or store them exposed directly to sunshine or high temperature/humidity.
- (6) Give careful consideration to avoid electrical static discharge with causes uneven contrast.
- (7) Even a small condensation on the contact pads (terminals) causes electro-chemical reaction which makes missing row and column. Give careful attention to avoid condensation. When assembling with zebra connector, clean the surface of the pads with alcohol and keep the air very clean.

14. LCD PRODUCT QUALITY STANDARD

(1) SAMPLING : MIL-STD-105E Serial II · AQL = 0.65(Major defect), 1.0(Minor defect)

(2) DISPLAY APPEARANCE

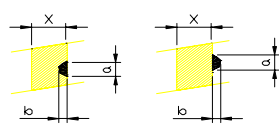
NO	ITEM	CRITERIA	CLASS																				
1.	INCLUSIONS (BLACK SPOT, WHITE SPOT, DUST)	(1) ROUND TYPE <table border="1" style="margin-left: 20px;"> <thead> <tr> <th>DIAMETER mm(a*)</th> <th>NO. OF DEFECT*</th> </tr> </thead> <tbody> <tr> <td>a ≤ 0.20</td> <td>NEGLECT</td> </tr> <tr> <td>0.20 < a ≤ 0.35</td> <td>5 MAX</td> </tr> <tr> <td>0.35 < a</td> <td>NONE</td> </tr> </tbody> </table> (2) LINEAR TYPE <table border="1" style="margin-left: 20px;"> <thead> <tr> <th>LENGTH mm(L)</th> <th>WIDTH mm(W)</th> <th>NO. OF DEFECT</th> </tr> </thead> <tbody> <tr> <td>NA</td> <td>w ≤ 0.03</td> <td>NEGLECT</td> </tr> <tr> <td>1 ≤ L ≤ 3</td> <td>0.03 < w ≤ 0.08</td> <td>6 MAX</td> </tr> <tr> <td>3 < L</td> <td>0.08 < w</td> <td>NONE</td> </tr> </tbody> </table>	DIAMETER mm(a*)	NO. OF DEFECT*	a ≤ 0.20	NEGLECT	0.20 < a ≤ 0.35	5 MAX	0.35 < a	NONE	LENGTH mm(L)	WIDTH mm(W)	NO. OF DEFECT	NA	w ≤ 0.03	NEGLECT	1 ≤ L ≤ 3	0.03 < w ≤ 0.08	6 MAX	3 < L	0.08 < w	NONE	Minor
DIAMETER mm(a*)	NO. OF DEFECT*																						
a ≤ 0.20	NEGLECT																						
0.20 < a ≤ 0.35	5 MAX																						
0.35 < a	NONE																						
LENGTH mm(L)	WIDTH mm(W)	NO. OF DEFECT																					
NA	w ≤ 0.03	NEGLECT																					
1 ≤ L ≤ 3	0.03 < w ≤ 0.08	6 MAX																					
3 < L	0.08 < w	NONE																					
2.	SCRATCH	1. SCRATCH ON PROTECTIVE FILM IS PERMITTED 2. SCRATCH ON POLARIZER SHALL BE AS FOLLOW: (1) ROUND TYPE <table border="1" style="margin-left: 20px;"> <thead> <tr> <th>DIAMETER mm(a*)</th> <th>NO. OF DEFECT</th> </tr> </thead> <tbody> <tr> <td>a ≤ 0.15</td> <td>NEGLECT</td> </tr> <tr> <td>0.15 < a ≤ 0.20</td> <td>2 MAX</td> </tr> <tr> <td>0.20 < a</td> <td>NONE</td> </tr> </tbody> </table> (2) LINEAR TYPE BE JUDGED BYE 1.-(2) LINEAR TYPE	DIAMETER mm(a*)	NO. OF DEFECT	a ≤ 0.15	NEGLECT	0.15 < a ≤ 0.20	2 MAX	0.20 < a	NONE	Minor												
DIAMETER mm(a*)	NO. OF DEFECT																						
a ≤ 0.15	NEGLECT																						
0.15 < a ≤ 0.20	2 MAX																						
0.20 < a	NONE																						
3.	DENT	DIAMETER < 1.5mm	Minor																				
4.	BUBBLE	NOT EXCEEDING 0.5mm AVERAGE DIAMETER IS ACCEPTABLE BETWEEN GLASS AND POLARIZING FILM.	Minor																				
5.	PIN HOLE	(a+b)/2 ≤ 0.15mm MAXIMUM NUMBER: IGNORED 0.15 < (a+b)/2 ≤ 0.20mm MAXIMUM NUMBER: 10 	Minor																				
6.	DOT DEFECT	(a+b)/2 ≤ 0.20mm MAXIMUM NUMBER: IGNORED 0.20 < (a+b)/2 ≤ 0.30mm MAXIMUM NUMBER: 5 X=WIDTH 	Minor																				
7.	CONTRAST IRREGULARITY(S POT)	<table border="1" style="margin-left: 20px;"> <thead> <tr> <th>DIAMETER SPEC</th> <th>NO. OF DEFECT</th> </tr> </thead> <tbody> <tr> <td>A ≤ 0.50mm</td> <td>NEGLECT</td> </tr> <tr> <td>0.50 < a ≤ 0.75</td> <td>5</td> </tr> <tr> <td>0.75 < a ≤ 1.00</td> <td>3</td> </tr> <tr> <td>1.00 < a</td> <td>NONE</td> </tr> </tbody> </table>	DIAMETER SPEC	NO. OF DEFECT	A ≤ 0.50mm	NEGLECT	0.50 < a ≤ 0.75	5	0.75 < a ≤ 1.00	3	1.00 < a	NONE	Minor										
DIAMETER SPEC	NO. OF DEFECT																						
A ≤ 0.50mm	NEGLECT																						
0.50 < a ≤ 0.75	5																						
0.75 < a ≤ 1.00	3																						
1.00 < a	NONE																						
8.	DOT WIDTH	DESIGN WIDTH ±15%	Minor																				
9.	COLOR TONE AND UNIFORMITY	OBVIOUS UNEVEN COLOR IS NOT PERMITTED	Minor																				

15. OUTLINE DIMENSIONS

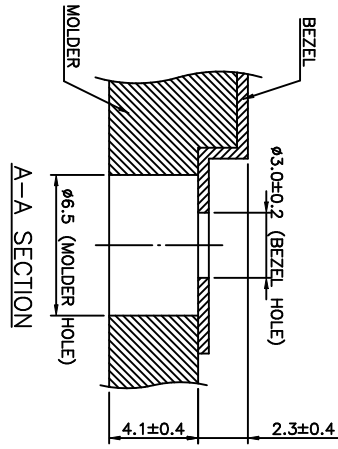

NOTE:

1. Resolution: 640X480 DOTS
 2. Backlight: CCFT
 3. Frame Material: SECC (0.5mmt)
 4. LCD Connector: 53261-1590 (MOLEX)
 5. CCT Connector: M63M83-04 (MITSUMI)
- correspondable CCFT connector : M60-04-30-114P (MITSUMI)
M60-04-30-134P (MITSUMI)
M61M73-04 (MITSUMI)
6. Tolerance No Specified: ±0.5mm

Pin No.	Symbol	Signal Level	Function
1	FLM	H	Scan Start-up Signal
2	CL1	H+L	Data Latch Pulse
3	CL2	H+L	Data Shift Pulse
4	DISP	H/L	Display Off ("H"=ON, "L"=OFF)
5	VDD	-	Power Supply for Logic (+5V)
6	VSS	-	Signal Ground (GND)
7	VEE	-	Power Supply for LCD (+V)
8	UD0	H/L	Display Data (Upper Half)
9	UD1	H/L	
10	UD2	H/L	
11	UD3	H/L	Display Data (Lower Half)
12	LD0	H/L	
13	LD1	H/L	
14	LD2	H/L	
15	LD3	H/L	

Pin No.	Symbol	Signal Level	Function
1	HV	-	High Voltage Line (Inverter)
2~3	NC	-	Non Connection
4	GND	-	Ground Line (Inverter)

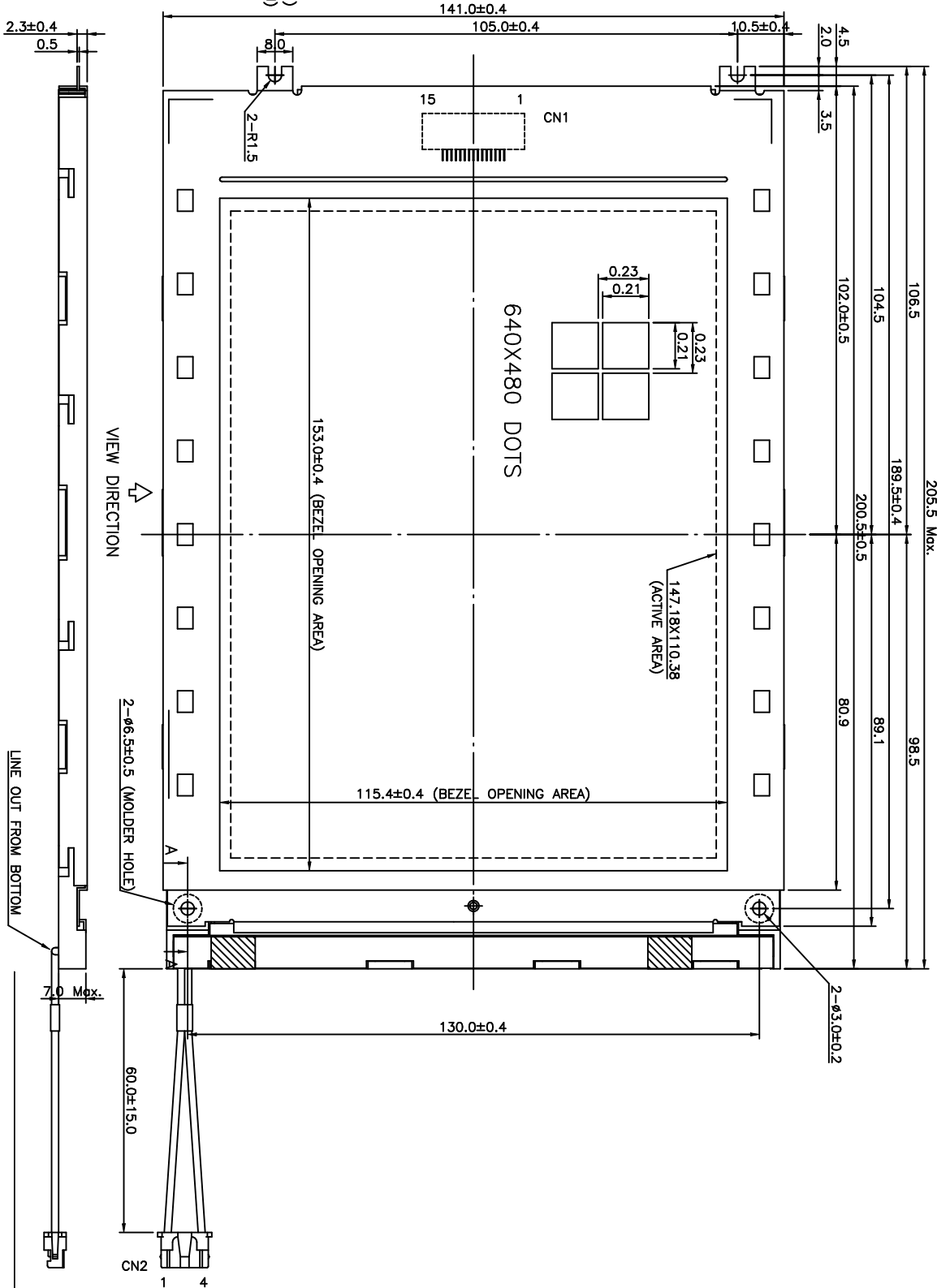

VIEW DIRECTION

LINE OUT FROM BOTTOM

CN2