



A Brighter Solution

# AMP DISPLAY INC.

## SPECIFICATIONS

### GRAPHIC LCD MODULE

CUSTOMER:	
CUSTOMER PART NO.	
AMP DISPLAY PART NO.	A G - 2 4 0 1 2 8 B
APPROVED BY:	
DATE:	

APPROVED FOR SPECIFICATIONS

APPROVED FOR SPECIFICATION AND PROTOTYPES

## AMP DISPLAY INC

9856 SIXTH STREET RANCHO CUCAMONGA CA 91730  
TEL: 909-980-13410 FAX: 909-980-1419  
WWW.AMPDISPLAY.COM

## RECORD OF REVISION

Revision Date	Contents
1999/11/24	New Release
2000/3/10	Remove the DC/DC converter
2000/10/6	Add power on / off sequence Modify sampling plan
2001/12/12	Modify LED characteristic
2007/2/7	Modify EL Back-light Characteristics(Page 6)

## 1 FEATURES

- (1) Display format : 240 × 128 dot-matrix ; 1/ 128 duty.
- (2) Construction : STN/FSTN LCD, Bezel, Zebra , Heat Seal and PCB.
- (3) Optional EL or CCFL back-light
- (4) Controller : T6963C.
- (5) Besides +5V for logic circuit, -20V is needed for LCD driving. DC/DC converter (for negative power supply) is available if special order.
- (6) Normal / Extended temperature type.

## 2 NUMBERING SYSTEM

**AG-240128B** \_ \_ \_ \_ - \_  
                   **1 2 3 4 5**

No	Code Value	Description	Remark
1	G	STN gray type LCD	LCD Type
	Y	STN yellow green type LCD	
	S	STN negative type LCD	
	F	FSTN type LCD	
2	A	Reflective type / 6:00 view	Polarizer / Viewing Angel
	B	Reflective type / 12:00 view	
	I	Transflective type / 6:00 view	
	J	Transflective type / 12:00 view	
	T	Negative type / 6:00 view	
	U	Negative type / 12:00 view	
3	None	Without backlight	Backlight type
	E	EL	
	C	CCFL	
4	None	Without backlight	Backlight color
	B	Blue	
	W	White	
5	None	Normal temperature type	LCM temperature type
	H	Extended temperature type	

### 3 MECHANICAL DATA

Parameter	Stand Value	Unit
Dot size	0.47(W) × 0.47(H)	mm
Dot pitch	0.50(W) × 0.50(H)	mm
Viewing area	132.0(W) × 76.0(H)	mm
Module size	170.0(W) × 103.2(H) × 14.0max (T)	mm

### 4 ABSOLUTE MAXIMUM RATINGS

Parameter		Symbol	Min	Max	Unit
Logic Circuit Supply Voltage		VDD-VSS	-0.3	7.0	V
LCD Driving Voltage		VDD-VO	-0.3	26.0	V
Input Voltage		VI	-0.3	VDD+0.3	V
Normal temp. type	Operating Temp.	TOP	0	50	°C
	Storage Temp.	TSTG	-20	70	°C
Extended temp. type	Operating Temp.	TOP	-20	70	°C
	Storage Temp.	TSTG	-30	80	°C

## 5 ELECTRO-OPTICAL CHARACTERISTICS

Parameter	Symbol	Condition	Min	Typ	Max	Unit	Note
<b>----- Electronic Characteristics -----</b>							
Logic Circuit Supply Voltage	VDD-VSS	--	4.5	5.0	5.5	V	
LCD Driving Voltage	VDD-VO	-20 °C	--	20.8	--	V	0 ~ 50 °C for Normal Temp. type -20 ~ 70 °C for Extended Temp. type
		0 °C	--	19.6	--		
		25 °C	--	18.5	--		
		50 °C	--	17.5	--		
		70 °C	--	16.6	--		
Input Voltage	VIH	--	0.7 VDD	--	VDD	V	
	VIL	--	VSS	--	0.3 VDD	V	
Logic Supply Current	IDD	VDD = 5V	--	15	--	mA	
<b>----- Optical Characteristics -----</b>							
Contrast	CR	STN type	--	5	--		Note 1
		FSTN type	--	8	--		
Rise Time	tr	25°C	--	200	400	ms	Note 2
Fall Time	tf	25°C	--	150	300	ms	
Viewing Angle Range	$\theta f$	25°C & CR $\geq$ 2	--	40	--	Deg.	Note 3
	$\theta b$		--	35	--		
	$\theta l$		--	35	--		
	$\theta r$		--	35	--		
Frame Frequency	fF	25°C	--	70	--	Hz	

(NOTE 1) Contrast ratio :

$$CR = (\text{Brightness in OFF state}) / (\text{Brightness in ON state})$$

(NOTE 2) Response time :

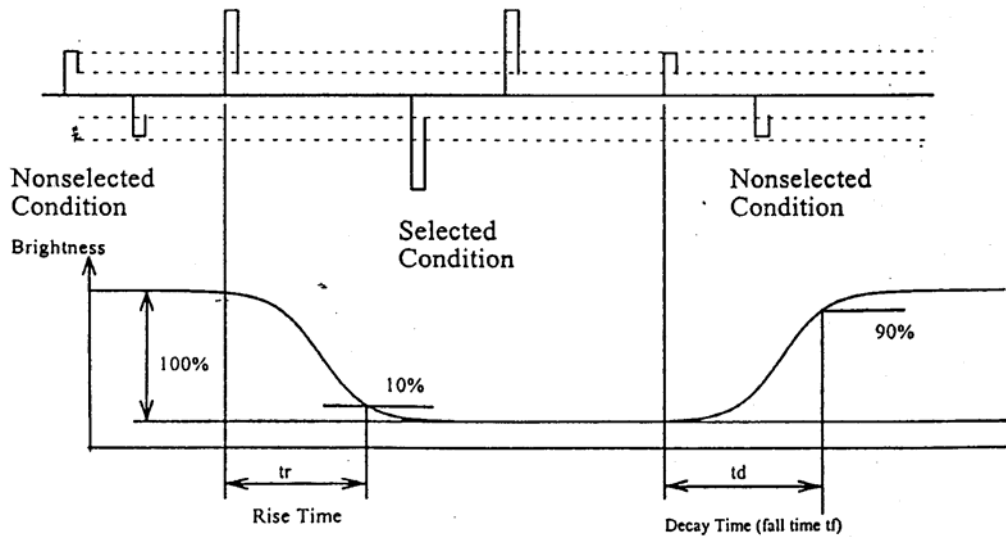

(NOTE 3) Viewing angle

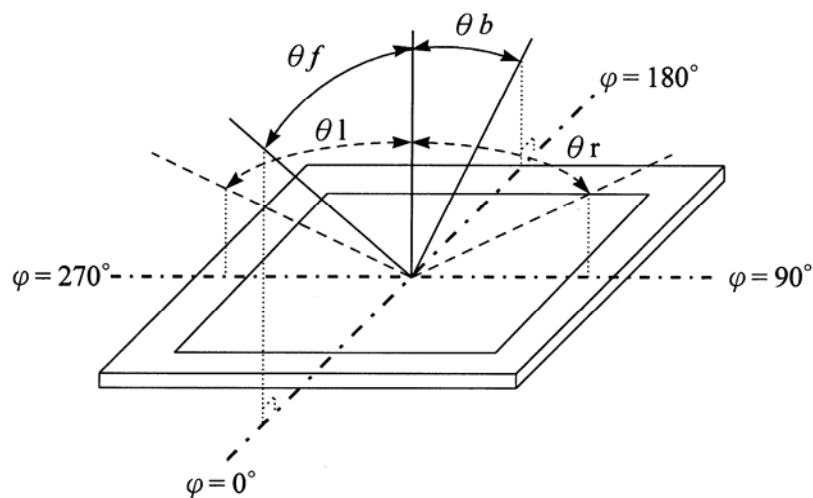

Parameter	Min	Typ	Max	Unit	Note
----- EL Back-light Characteristics -----					
Driving Voltage	--	110	--	Vrms	
Frequency	--	400	--	Hz	
LCM Luminous intensity	--	5	--	cd/m <sup>2</sup>	

## 5.1 C.C.F.L. BACK-LIGHT SPECIFICATION

(1) The half-brightness life of the back light shall be kept as specified under the following absolute maximum conditions:

Power Consumption	1.8 W
TA = 25°C, fL = 30KHz	(with TDK CXA-L10L Inverter)
Tube current	3mArms min
TA = 25°C, fL = 30KHz	5mArms max.

(2) Electrical Characteristics

The following operating conditions are recommended for the back light unit.

Start Voltage	1000 Vrms min, at Ta=0 °C
Tube Voltage	360 Vrms typ, at Ta=25 °C
Tube Current	5 mArms typ, at Ta=25 °C
Drive Frequency	30 KHz typ, at Ta=25 °C

(3) Initial Optical Characteristics

The unit shall satisfy the following criteria at 25±2°C ambient temperature, 30% - 85% relative humidity, no air flow and with applying rating input voltage and input current by using TDK CXA-L10L inverter.

Item	Min	Typ	Max	Unit	Note
LCD Module Brightness	--	140	--	Cd/m <sup>2</sup>	1
Brightness Uniformity	75%	--	--	%	
Chromaticity X	0.331	0.336	0.340		
Y	0.371	0.376	0.382		

NOTE 1: Ave. brightness should be measured 30 min. after initial power on.

(4) Life

Half-Brightness Life of Unit 10,000 Hours min.

The definition of half-brightness life is either average brightness reach to 50% of initial average brightness or lamp stopping light emission.

## 6 BLOCK DIAGRAM & POWER SUPPLY

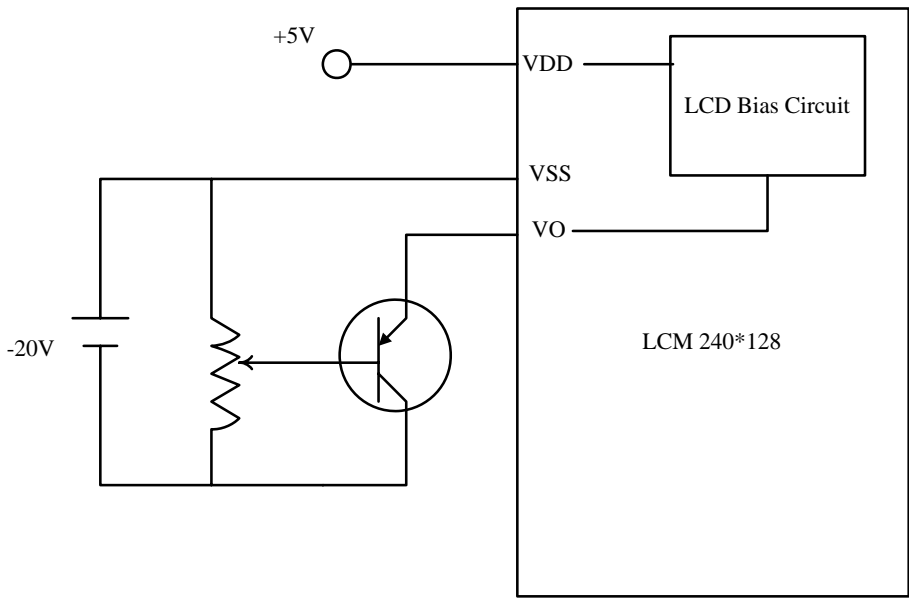
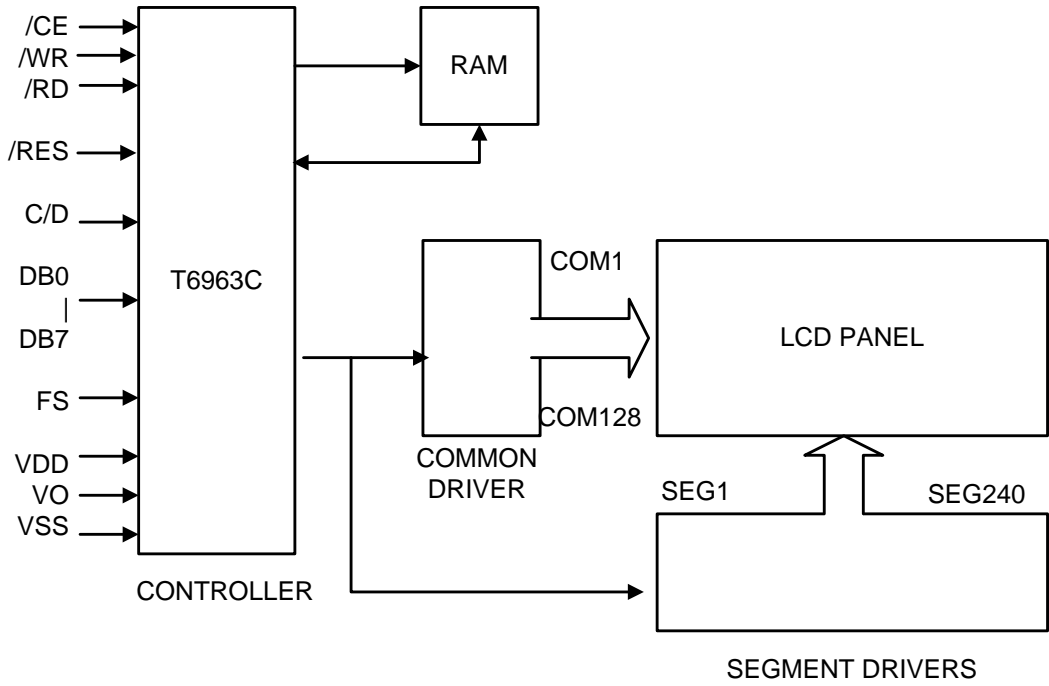

Using EL Back-light

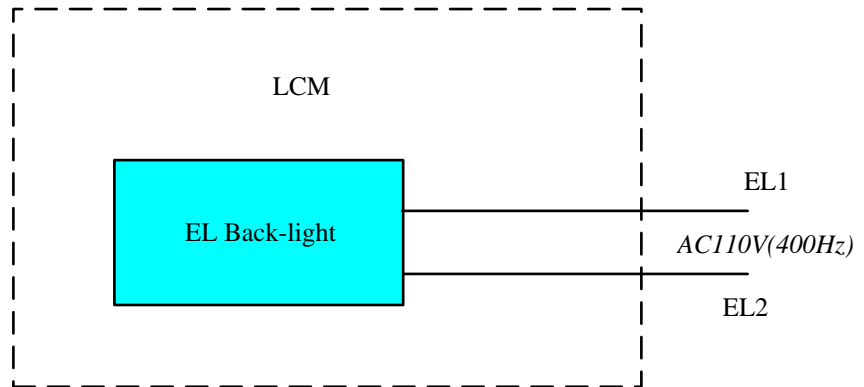

Using CCFL Back-light

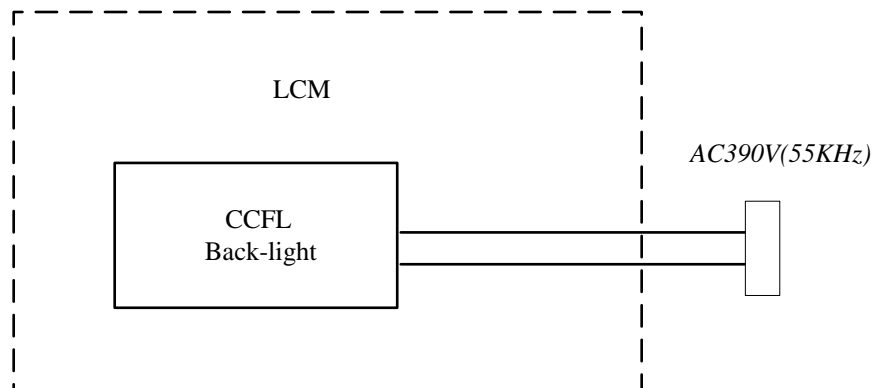

## 7 PIN CONNECTIONS

Pin No.	Symbol	Function
1	FG	Frame Ground
2	VSS	Power Supply (0V)
3	VDD	Power Login Supply Voltage(+5V)
4	VO	LCD supply voltage (-)
5	/WR	Write data when WR = L
6	/RD	Read data when RD = L
7	/CE	Chip Enable
8	C/D	WR = L --- C/D = H : Command Write    C/D = L : Data Write RD = L --- C/D = H : Status Read        C/D = L : Data Read
9	NC	No Connection
10	/RES	H --- Normal    L --- Initialize T6963C
11 - 18	DB0 - DB7	Data Bus Line
19	FS	Pin for selection of font    H --- Font 6x8    L --- Font 8x8
20	NC	No Connection

## 8 TIMING CHARACTERISTICS

### Bus Timing

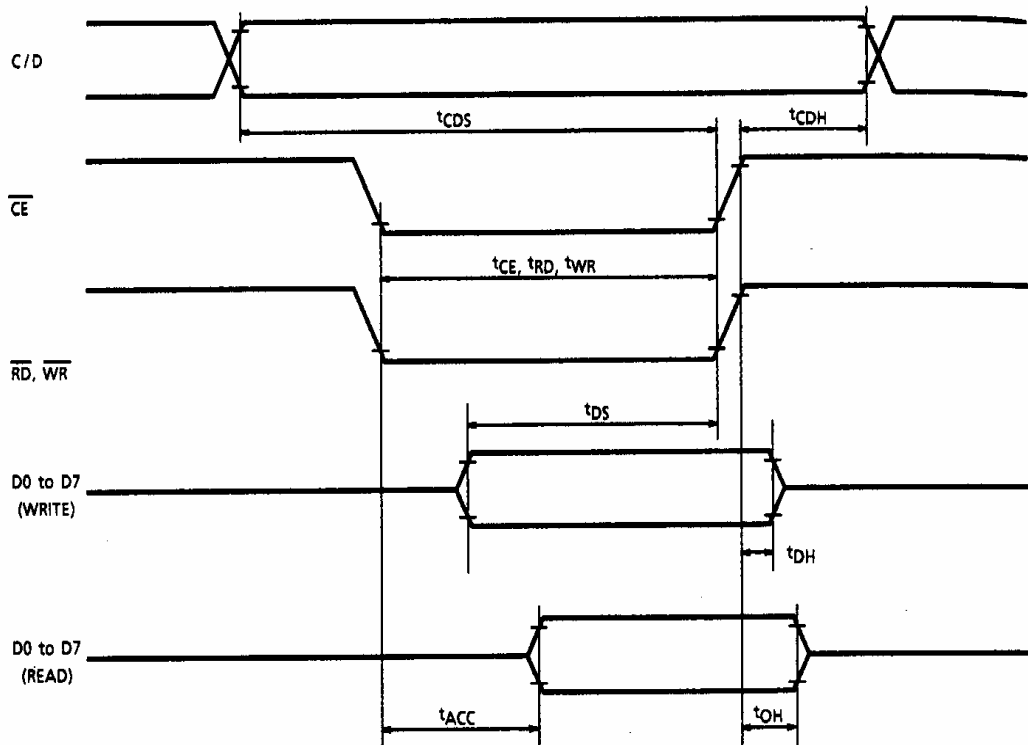

TEST CONDITIONS (Unless otherwise noted,  $V_{DD} = 5.0V \pm 10\%$ ,  $V_{SS} = 0V$ ,  $T_a = -20$  to  $75^\circ C$ )

ITEM	SYMBOL	TEST CONDITIONS	MIN	MAX	UNIT
C/D Set-up Time	$t_{CDS}$	—	100	—	ns
C/D Hold Time	$t_{CDH}$	—	10	—	ns
CE, RD, WR Pulse Width	$t_{CE, t_{RD}, t_{WR}}$	—	80	—	ns
Data Set-up Time	$t_{DS}$	—	80	—	ns
Data Hold Time	$t_{DH}$	—	40	—	ns
Access Time	$t_{ACC}$	—	—	150	ns
Output Hold Time	$t_{OH}$	—	10	50	ns

# 8.1 Power ON/OFF Sequence

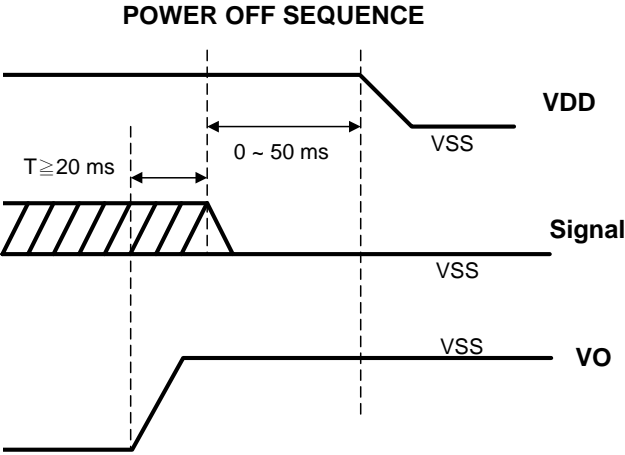
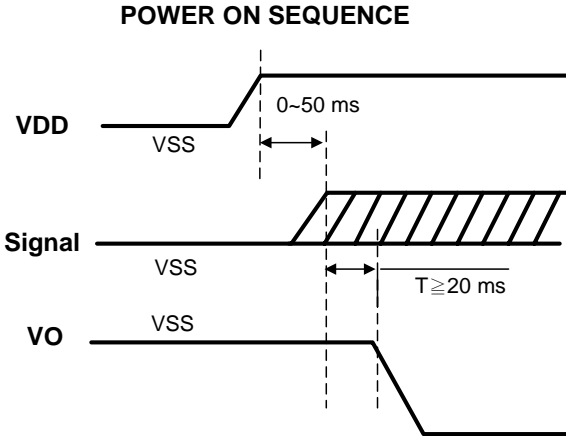

## **9 QUALITY AND RELIABILITY**

### **9.1 TEST CONDITIONS**

Tests should be conducted under the following conditions :

Ambient temperature :  $25 \pm 5^{\circ}\text{C}$

Humidity :  $60 \pm 25\% \text{ RH}$ .

### **9.2 SAMPLING PLAN**

Sampling method shall be in accordance with MIL-STD-105E , level II, normal single sampling plan .

### **9.3 ACCEPTABLE QUALITY LEVEL**

A major defect is defined as one that could cause failure to or materially reduce the usability of the unit for its intended purpose. A minor defect is one that does not materially reduce the usability of the unit for its intended purpose or is an infringement from established standards and has no significant bearing on its effective use or operation.

### **9.4 APPEARANCE**

An appearance test should be conducted by human sight at approximately 30 cm distance from the LCD module under fluorescent light. The inspection area of LCD panel shall be within the range of following limits.

## 9.5 INSPECTION QUALITY CRITERIA

Item	Description of defects			Class of Defects	Acceptable level (%)
Function	Short circuit or Pattern cut			Major	0.65
Dimension	Deviation from drawings			Major	1.5
Black spots	Ave . dia . D	area A	area B	Minor	2.5
	$D \leq 0.2$	Disregard			
	$0.2 < D \leq 0.3$	3	4		
	$0.3 < D \leq 0.4$	2	3		
	$0.4 < D$	0	1		
Black lines	Width W, Length L	A	B	Minor	2.5
	$W \leq 0.03$	disregard			
	$0.03 < W \leq 0.05$	3	4		
	$0.05 < W \leq 0.07, L \leq 3.0$	1	1		
	See line criteria				
Bubbles in polarizer	Average diameter D $0.2 < D < 0.5$ mm for N = 4 , D > 0.5 for N = 1			Minor	2.5
Color uniformity	Rainbow color or newton ring.			Minor	2.5
Glass Scratches	Obvious visible damage.			Minor	2.5
Contrast ratio	See note 1			Minor	2.5
Response time	See note 2			Minor	2.5
Viewing angle	See note 3			Minor	2.5

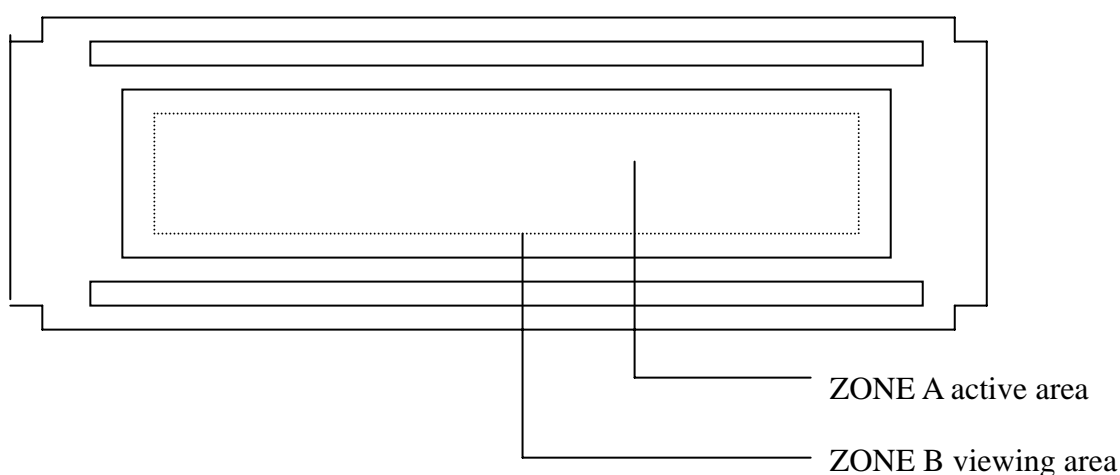

## 9.6 RELIABILITY

Test Item	Test Conditions		Note
	Normal Temp. type	Extended Temp. type	
High Temperature Operation	50±3°C , t=96 hrs	70±3°C , t=96 hrs	
Low Temperature Operation	0±3°C , t=96 hrs	-20±3°C , t=96 hrs	
High Temperature Storage	70±3°C , t=96 hrs	80±3°C , t=96 hrs	1,2
Low Temperature Storage	-20±3°C , t=96 hrs	-30±3°C , t=96 hrs	1,2
Temperature Cycle	-20°C ~ 25°C ~ 70°C 30 m in. 5 min. 30 min. ( 1 cycle ) Total 5 cycle	-30°C ~ 25°C ~ 80°C 30 min. 5 min. 30 min. ( 1 cycle ) Total 5 cycle	1,2
Humidity Test	40 °C, Humidity 90%, 96 hrs		1,2
Vibration Test (Packing)	Sweep frequency : 10 ~ 55 ~ 10 Hz/1min Amplitude : 0.75mm Test direction : X.Y.Z/3 axis Duration : 30min/each axis		2

Note 1 : Condensation of water is not permitted on the module.

Note 2 : The module should be inspected after 1 hour storage in normal conditions  
(15-35°C , 45-65%RH).

Definitions of life end point :

- Current drain should be smaller than the specific value.
- Function of the module should be maintained.
- Appearance and display quality should not have degraded noticeably.
- Contrast ratio should be greater than 50% of the initial value.

## **10 HANDLING PRECAUTIONS**

- (1) A LCD module is a fragile item and should not be subjected to strong mechanical shocks.
- (2) Avoid applying pressure to the module surface. This will distort the glass and cause a change in color.
- (3) Under no circumstances should the position of the bezel tabs or their shape be modified.
- (4) Do not modify the display PCB in either shape or positioning of components.
- (5) Do not modify or move location of the zebra or heat seal connectors.
- (6) The device should only be soldered to during interfacing. Modification to other areas of the board should not be carried out.
- (7) In the event of LCD breakage and resultant leakage of fluid do not inhale, ingest or make contact with the skin. If contact is made rinse immediately.
- (8) When cleaning the module use a soft damp cloth with a mild solvent, such as Isopropyl or Ethyl alcohol. The use of water, ketone or aromatic is not permitted.
- (9) Prior to initial power up input signals should not be applied.
- (10) Protect the module against static electricity and observe appropriate anti-static precautions.

