



晶采光電科技股份有限公司  
AMPIRE CO., LTD.

## SPECIFICATIONS FOR LCD MODULE

|                          |                      |
|--------------------------|----------------------|
| <b>CUSTOMER</b>          |                      |
| <b>CUSTOMER PART NO.</b> |                      |
| <b>AMPIRE PART NO.</b>   | <b>AC-161JYILY-H</b> |
| <b>APPROVED BY</b>       |                      |
| <b>DATE</b>              |                      |

**AMPIRE CO., LTD.**

**TOWER A, 4F, No.114, Sec. 1, HSIN-TAI 5th RD., HIS-CHIH,  
TAIPEI HSIEN, TAIWAN(R.O.C.)**

**台北縣汐止鎮新台五路一段114號4樓(東方科學園區A棟)**

**TEL:886-2-26967269, FAX:886-2-26967196 or 886-2-26967270**

| <b>APPROVED BY</b> | <b>CHECKED BY</b> | <b>ORGANIZED BY</b> |
|--------------------|-------------------|---------------------|
|                    |                   |                     |

## RECORD OF REVISION

| Revision Date | Page | Contents    |
|---------------|------|-------------|
| 2002/7/22     | -    | New Release |

## 1 FEATURES

- (1) Display format : 16 characters × 1 lines
- (2) Construction : LCD panel, Bezel, Zebra , Yellow-green LED back-light and PCB.
- (3) Display type ; STN , Yellow-green mode , Transflective, 6 o'clock view.
- (4) Controller : *ST7066U-0A*.
- (5) 5V single power input.
- (6) Extended temperature type.

## 2 MECHANICAL DATA

| Parameter      | Stand Value                       | Unit |
|----------------|-----------------------------------|------|
| Dot size       | 1.152 (W) × 1.765(H)              | mm   |
| Dot pitch      | 1.158(W) × 1.171(H)               | mm   |
| Character size | 6.0(W) × 14.54(H)                 | mm   |
| Viewing area   | 120.0(W) × 23.0(H)                | mm   |
| Module size    | 151.0(W) × 40.0(H) × 14.7 max (T) | mm   |

## 3 ABSOLUTE MAXIMUM RATINGS

| Parameter                    | Symbol          | Min  | Max     | Unit |    |
|------------------------------|-----------------|------|---------|------|----|
| Logic Circuit Supply Voltage | VDD-VSS         | -0.3 | 7.0     | V    |    |
| LCD Driving Voltage          | VDD-VO          | -0.3 | 10.0    | V    |    |
| Input Voltage                | VI              | -0.3 | VDD+0.3 | V    |    |
| Extended temp. type          | Operating Temp. | TOP  | -20     | 70   | °C |
|                              | Storage Temp.   | TSTG | -30     | 80   | °C |

## 4 ELECTRO-OPTICAL CHARACTERISTICS

| Parameter   | Symbol  | Condition   | Min     | Typ  | Max     | Unit              | Note                             |
|---|---------|-------------|---------|------|---------|-------------------|----------------------------------|
| <b>----- Electronic Characteristics -----</b>               |         |             |         |      |         |                   |                                  |
| Logic Circuit Supply Voltage                                | VDD-VSS | --          | 2.7     | --   | 5.5     | V                 |                                  |
| LCD Driving Voltage ( STN )                                 | VDD-VO  | -20 °C      | 4.75    | 5.0  | 5.25    | V                 | -20~70°C for Extended Temp. type |
|   |         | 0 °C        | 4.75    | 5.0  | 5.25    |                   |                                  |
|   |         | 25 °C       | 4.75    | 5.0  | 5.25    |                   |                                  |
|   |         | 50°C        | 4.75    | 5.0  | 5.25    |                   |                                  |
|   |         | 70 °C       | 4.75    | 5.0  | 5.25    |                   |                                  |
| Input Voltage   | VIH     | --          | 0.7 VDD | --   | VDD     | V                 |                                  |
|   | VIL     | --          | VSS     | --   | 0.3 VDD | V                 |                                  |
| Logic Supply Current  | IDD     | VDD = 5V    | --      | 2.0  | 2.4     | mA                |                                  |
| <b>----- Optical Characteristics ( STN ) -----</b>          |         |             |         |      |         |                   |                                  |
| Contrast  | CR      | 25°C        | --      | 5    | --      |                   | Note 1                           |
| Rise Time   | tr      | 25°C        | --      | 80   | 120     | ms                | Note 2                           |
| Fall Time   | tf      | 25°C        | --      | 150  | 300     | ms                |                                  |
| Viewing Angle Range   | θ f     | 25°C & CR≥2 | --      | 40   | --      | Deg.              | Note 3                           |
|   | θ b     |             | --      | 35   | --      |                   |                                  |
|   | θ l     |             | --      | 35   | --      |                   |                                  |
|   | θ r     |             | --      | 35   | --      |                   |                                  |
| Frame Frequency   | fF      | 25°C        | --      | 64   | --      | Hz                |                                  |
| <b>-----Array type LED Back-light Characteristics -----</b> |         |             |         |      |         |                   |                                  |
| Parameter   | Symbol  | Condition   | Min     | Typ  | Max     | Unit              | Note                             |
| Forward Voltage   | VF      | --          | --      | 4.05 | 4.3     | V                 | Supply Voltage between A&K       |
| Forward Current   | IF      | VF=4.05V    | --      | 420  | --      | mA                |                                  |
| Bare LED Luminous intensity                                 |         | VF=4.05V    | --      | 100  | --      | cd/m <sup>2</sup> |                                  |
| LCM Luminous intensity                                      |         | VF=4.05V    | --      | 30   | --      | cd/m <sup>2</sup> |                                  |

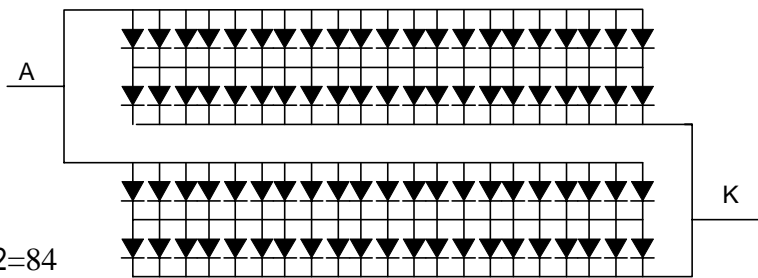

\* LED Dice number =  $2 \times 42 = 84$

(NOTE 1) Contrast ratio :  $CR = (\text{Brightness in OFF state}) / (\text{Brightness in ON state})$

(NOTE 2) Response time :

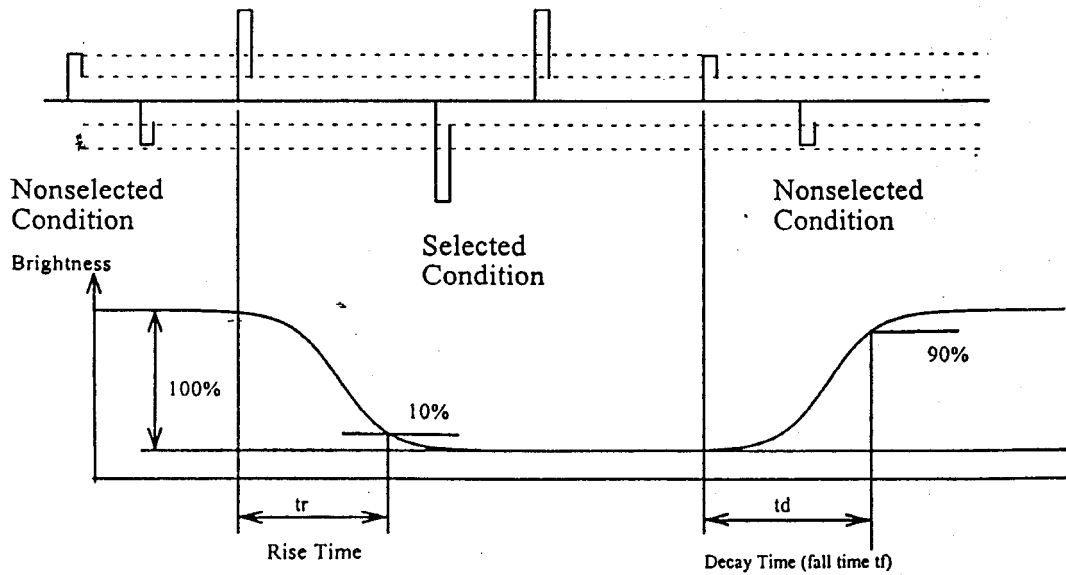

(NOTE 3) Viewing angle

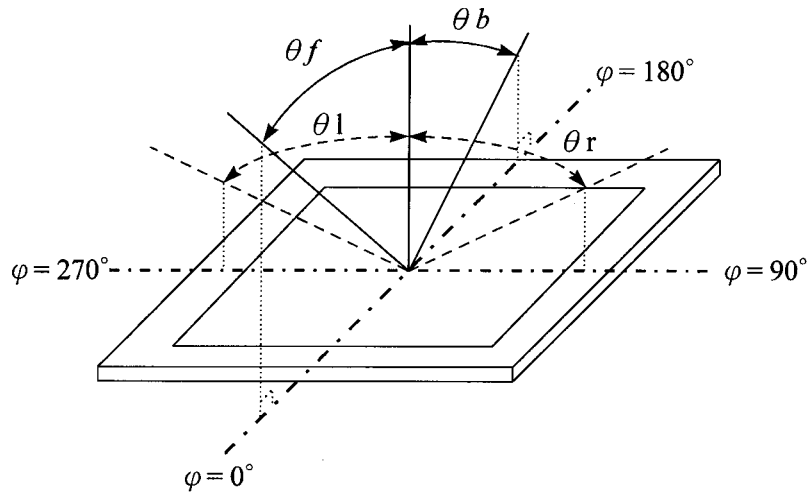

## 5 BLOCK DIAGRAM & POWER SUPPLY

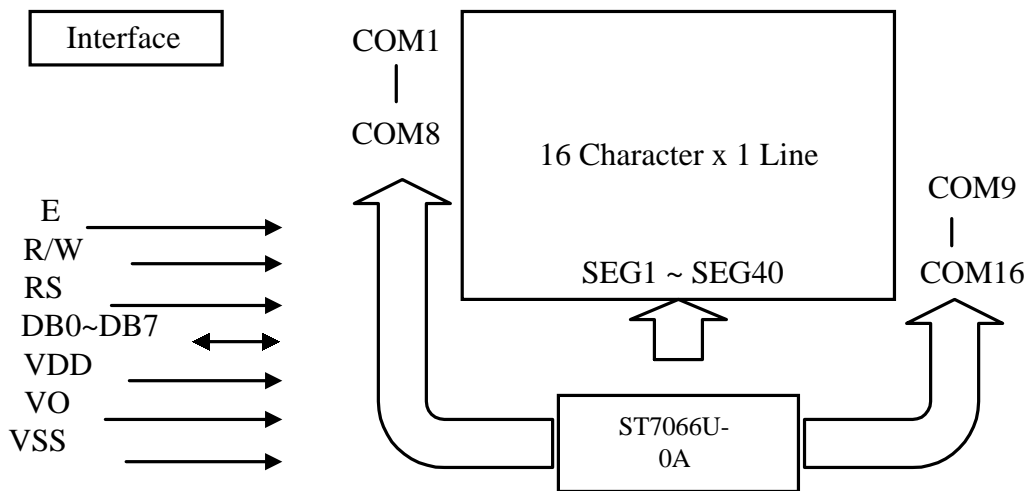

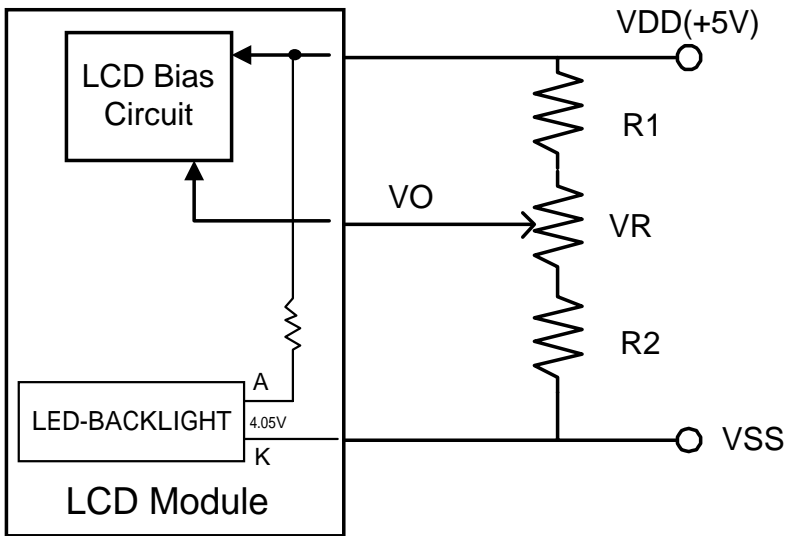

5V Power Input

## 6 INTERFACE

| No. | Symbol | Function                        |
|-----|--------|---------------------------------|
| 1   | VSS    | Ground (0V)                     |
| 2   | VDD    | Supply Voltage for Logic (+5V ) |
| 3   | VO     | Contrast Adjustment             |
| 4   | RS     | Data/Instruction Select         |
| 5   | R/W    | Read/Write Select               |
| 6   | E      | Enable Signal                   |
| 7   | DB0    | Data Bus                        |
| 8   | DB1    | Data Bus                        |
| 9   | DB2    | Data Bus                        |
| 10  | DB3    | Data Bus                        |
| 11  | DB4    | Data Bus                        |
| 12  | DB5    | Data Bus                        |
| 13  | DB6    | Data Bus                        |
| 14  | DB7    | Data Bus                        |

## 7 TIMING CHARACTERISTICS

### Write Operation

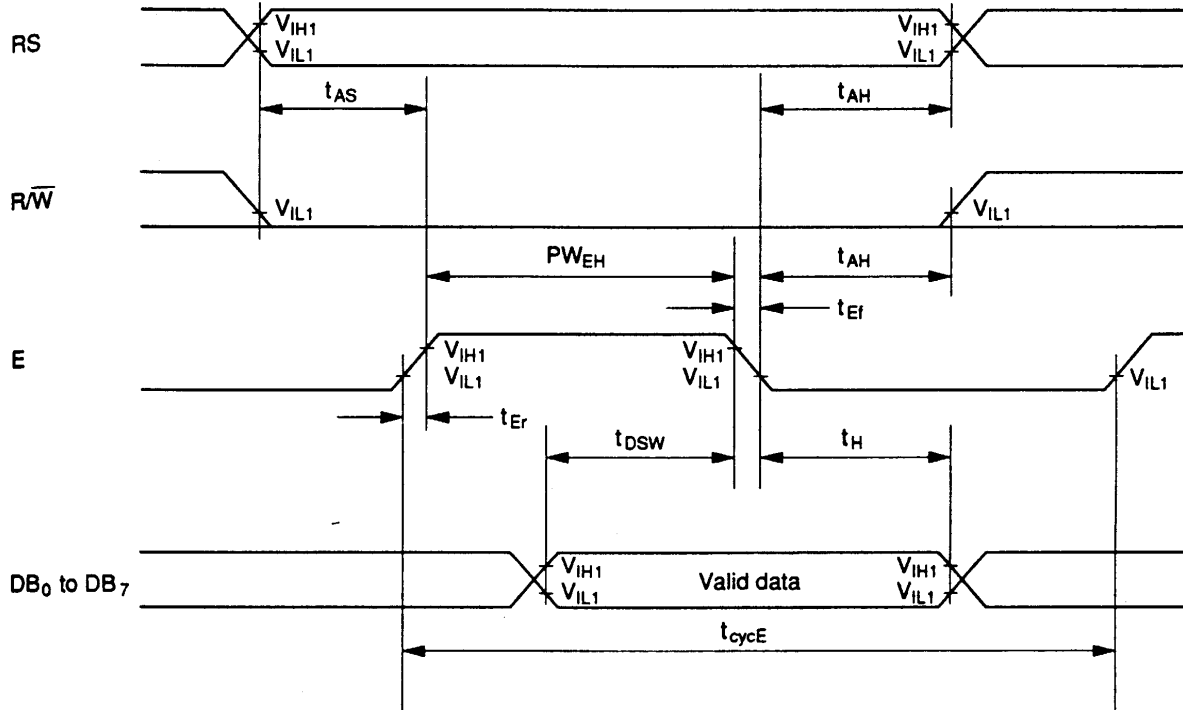

| Item                                  | Symbol                           | VDD=5V |     | VDD=3.3V |     | Unit |
|---------------------------------------|----------------------------------|--------|-----|----------|-----|------|
|                                       |                                  | Min    | Max | Min      | Max |      |
| Enable cycle time                     | t <sub>cycE</sub>                | 500    | --  | 1000     | --  | ns   |
| Enable pulse width                    | P <sub>WEH</sub>                 | 230    | --  | 450      | --  |      |
| Enable rise/fall time                 | t <sub>Er</sub> ,t <sub>Ef</sub> | --     | 20  | --       | 25  |      |
| Address set-up time<br>(RS, R/W to E) | t <sub>AS</sub>                  | 40     | --  | 60       | --  |      |
| Address hold time                     | t <sub>AH</sub>                  | 10     | --  | 20       | --  |      |
| Data set-up time                      | t <sub>DSW</sub>                 | 80     | --  | 195      | --  |      |
| Data hold time                        | t <sub>H</sub>                   | 10     | --  | 10       | --  |      |

## Read Operation

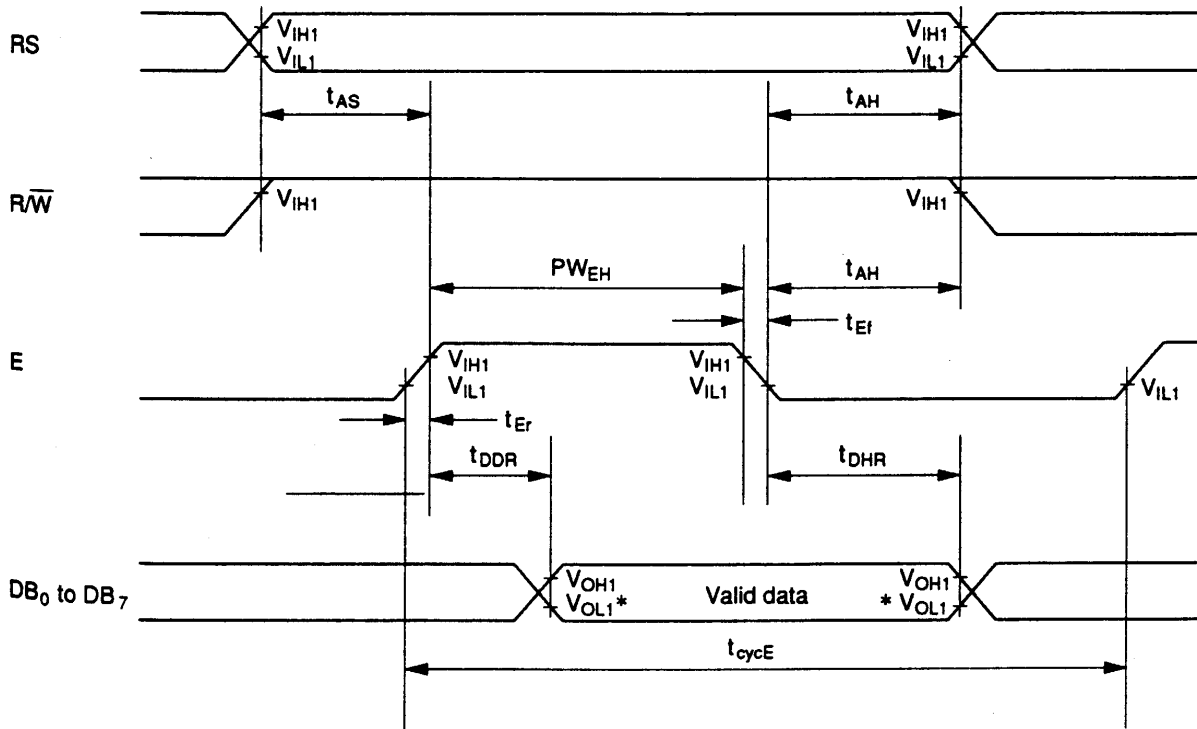

| Item                                  | Symbol                           | VDD=5V |     | VDD=3.3V |     | Unit |
|---------------------------------------|----------------------------------|--------|-----|----------|-----|------|
|                                       |                                  | Min    | Max | Min      | Max |      |
| Enable cycle time                     | t <sub>cycE</sub>                | 500    | --  | 1000     | --  | ns   |
| Enable pulse width                    | P <sub>WEH</sub>                 | 230    | --  | 450      | --  |      |
| Enable rise/fall time                 | t <sub>Er</sub> ,t <sub>Ef</sub> | --     | 20  | --       | 25  |      |
| Address set-up time<br>(RS, R/W to E) | t <sub>AS</sub>                  | 40     | --  | 60       | --  |      |
| Address hold time                     | t <sub>AH</sub>                  | 10     | --  | 20       | --  |      |
| Data delay time                       | t <sub>DDR</sub>                 | --     | 120 | --       | 360 |      |
| Data hold time                        | t <sub>DRH</sub>                 | 5      | --  | 5        | --  |      |

## 8 INSTRUCTION SET

| Instruction                | Code |         |    |         |         |         |         |         |         |         | Description   | E.T.(fosc<br>=270<br>KHZ) |
|----------------------------|------|---------|----|---------|---------|---------|---------|---------|---------|---------|---|---------------------------|
|                            | RS   | R/<br>W | D7 | D6      | D5      | D4      | D3      | D2      | D1      | D0      |   |                           |
| Clear Display              | 0    | 0       | 0  | 0       | 0       | 0       | 0       | 0       | 0       | 1       | Write "20H" to DDRAM and set DDRAM address to "00H" from AC   | 1.53 ms                   |
| Return Home                | 0    | 0       | 0  | 0       | 0       | 0       | 0       | 0       | 1       | --      | Sets DD RAM address to "00H" from AC and return cursor to its original position if shifted. The contents of DDRAM are not changed.    | 1.53 ms                   |
| Entry Mode SET             | 0    | 0       | 0  | 0       | 0       | 0       | 0       | 1       | I/D     | SH      | Assign cursor moving direction and enable the shift of entire display.  | 39 μS                     |
| Display ON/OFF Control     | 0    | 0       | 0  | 0       | 0       | 0       | 1       | D       | C       | B       | Set display (D), cursor (C), and blink of cursor (B) on/off control bit.  | 39 μS                     |
| Cursor or Display Shift    | 0    | 0       | 0  | 0       | 0       | 1       | S/<br>C | R/<br>L | --      | --      | Set cursor moving and display shift control bit, and the direction, without changing of DDRAM data.                                   | 39 μS                     |
| Function Set               | 0    | 0       | 0  | 0       | 1       | DL      | N       | F       | --      | --      | Sets interface data length (DL:8-bit/4-bit), number of display lines (N:2-line/1-line) and , display font type (F:5x11dots/5x8 dost). | 39 μS                     |
| Set CG RAM Address         | 0    | 0       | 0  | 1       | AC<br>5 | AC<br>4 | AC<br>3 | AC<br>2 | AC<br>1 | AC<br>0 | Sets CG RAM address in address counter.   | 39 μS                     |
| Set DD RAM Address         | 0    | 0       | 1  | AC<br>6 | AC<br>5 | AC<br>4 | AC<br>3 | AC<br>2 | AC<br>1 | AC<br>0 | Sets DD RAM address in address counter.   | 39 μS                     |
| Read Busy Flag and Address | 0    | 1       | BF | AC<br>6 | AC<br>5 | AC<br>4 | AC<br>3 | AC<br>2 | AC<br>1 | AC<br>0 | Whether during internal operation or not can be known by reading BF. The contents of address counter can also be read.                | 0 μS                      |
| Write Data to RAM          | 1    | 0       | D7 | D6      | D5      | D4      | D3      | D2      | D1      | D0      | Writes data into internal RAM (DD RAM /CG RAM).   | 43 μS                     |
| Read Data from RAM         | 1    | 1       | D7 | D6      | D5      | D4      | D3      | D2      | D1      | D0      | Reads data from internal RAM (DD RAM /CG RAM).  | 43 μS                     |

\* "--" : don't care

Note : When an MPU program with checking the Busy Flag(DB7) is made, it must be necessary 1/2Fosc is necessary for executing the next instruction by the falling edge of the 'E' signal after the Busy Flag(DB7) goes to "LOW".

## 9 INITIALIZATION SEQUENCE

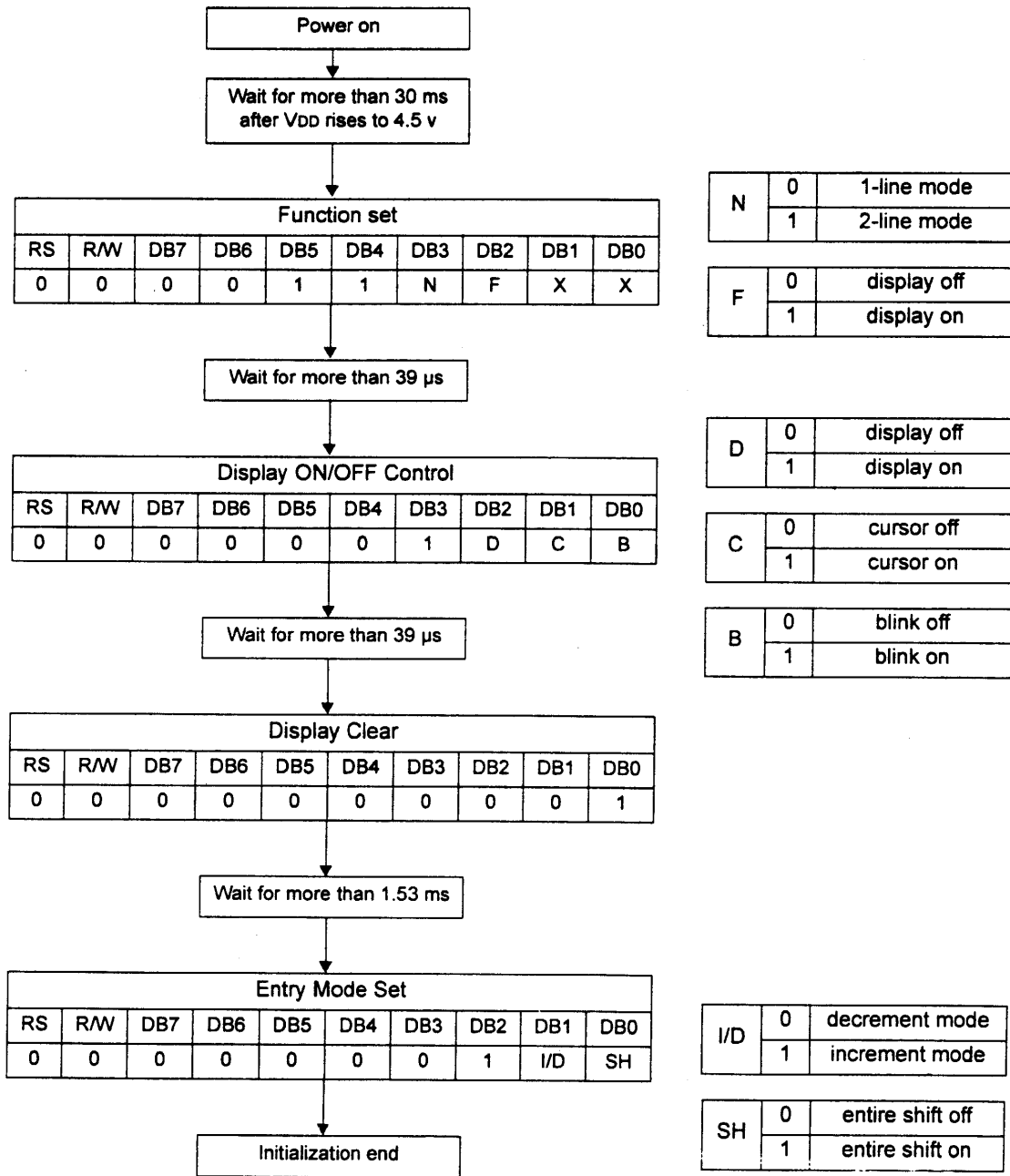

## 10 DD RAM ADDRESS

| DIGIT  | 1  | 2  | 3  | 4  | 5  | 6  | 7  | 8  | 9  | 10 | 11 | 12 | 13 | 14 | 15 | 16 |
|--------|----|----|----|----|----|----|----|----|----|----|----|----|----|----|----|----|
| 1 LINE | 00 | 01 | 02 | 03 | 04 | 05 | 06 | 07 | 40 | 41 | 42 | 43 | 44 | 45 | 46 | 47 |

Display Position  
DD RAM Address

# 11 FONT TABLE

| Upper<br>4bit<br>Lower<br>4bit | LLLL | LLLH             | LLHL | LLHH | LHLL | LHLH | LHHL | LHHH | HLLL | HLLH | HLHL | HLHH | HHLL | HHLH | HHHL | HHHH |
|--------------------------------|------|------------------|------|------|------|------|------|------|------|------|------|------|------|------|------|------|
|                                | LLLL | CG<br>RAM<br>(1) |      |      |      |      |      |      |      |      |      |      |      |      |      |      |
| LLLH                           | (2)  |                  |      |      |      |      |      |      |      |      |      |      |      |      |      |      |
| LLHL                           | (3)  |                  |      |      |      |      |      |      |      |      |      |      |      |      |      |      |
| LLHH                           | (4)  |                  |      |      |      |      |      |      |      |      |      |      |      |      |      |      |
| LHLL                           | (5)  |                  |      |      |      |      |      |      |      |      |      |      |      |      |      |      |
| LHLH                           | (6)  |                  |      |      |      |      |      |      |      |      |      |      |      |      |      |      |
| LHHL                           | (7)  |                  |      |      |      |      |      |      |      |      |      |      |      |      |      |      |
| LHHH                           | (8)  |                  |      |      |      |      |      |      |      |      |      |      |      |      |      |      |
| HLLL                           | (1)  |                  |      |      |      |      |      |      |      |      |      |      |      |      |      |      |
| HLLH                           | (2)  |                  |      |      |      |      |      |      |      |      |      |      |      |      |      |      |
| HLHL                           | (3)  |                  |      |      |      |      |      |      |      |      |      |      |      |      |      |      |
| HLHH                           | (4)  |                  |      |      |      |      |      |      |      |      |      |      |      |      |      |      |
| HHLL                           | (5)  |                  |      |      |      |      |      |      |      |      |      |      |      |      |      |      |
| HHLH                           | (6)  |                  |      |      |      |      |      |      |      |      |      |      |      |      |      |      |
| HHHL                           | (7)  |                  |      |      |      |      |      |      |      |      |      |      |      |      |      |      |
| HHHH                           | (8)  |                  |      |      |      |      |      |      |      |      |      |      |      |      |      |      |

## **12 QUALITY AND RELIABILITY**

### **12.1 TEST CONDITIONS**

Tests should be conducted under the following conditions :

Ambient temperature :  $25 \pm 5^{\circ}\text{C}$

Humidity :  $60 \pm 25\% \text{ RH}$ .

### **12.2 SAMPLING PLAN**

Sampling method shall be in accordance with MIL-STD-105E , level II, normal single sampling plan .

### **12.3 ACCEPTABLE QUALITY LEVEL**

A major defect is defined as one that could cause failure to or materially reduce the usability of the unit for its intended purpose. A minor defect is one that does not materially reduce the usability of the unit for its intended purpose or is an infringement from established standards and has no significant bearing on its effective use or operation.

### **12.4 APPEARANCE**

An appearance test should be conducted by human sight at approximately 30 cm distance from the LCD module under flourescent light. The inspection area of LCD panel shall be within the range of following limits.

## 12.5 INSPECTION QUALITY CRITERIA

| Item                 | Description of defects  |           |        | Class of Defects | Acceptable level (%) |
|----------------------|---|-----------|--------|------------------|----------------------|
| Function             | Short circuit or Pattern cut  |           |        | Major            | 0.65                 |
| Dimension            | Deviation from drawings   |           |        | Major            | 1.5                  |
| Black spots          | Ave . dia . D   | area A    | area B | Minor            | 2.5                  |
|                      | $D \leq 0.2$  | Disregard |        |                  |                      |
|                      | $0.2 < D \leq 0.3$  | 3         | 4      |                  |                      |
|                      | $0.3 < D \leq 0.4$  | 2         | 3      |                  |                      |
|                      | $0.4 < D$   | 0         | 1      |                  |                      |
| Black lines          | Width W, Length L   | A         | B      | Minor            | 2.5                  |
|                      | $W \leq 0.03$   | disregard |        |                  |                      |
|                      | $0.03 < W \leq 0.05$  | 3         | 4      |                  |                      |
|                      | $0.05 < W \leq 0.07, L \leq 3.0$                                    | 1         | 1      |                  |                      |
|                      | See line criteria   |           |        |                  |                      |
| Bubbles in polarizer | Average diameter D $0.2 < D < 0.5$ mm for N = 4 , D > 0.5 for N = 1 |           |        | Minor            | 2.5                  |
| Color uniformity     | Rainbow color or newton ring.                                       |           |        | Minor            | 2.5                  |
| Glass Scratches      | Obvious visible damage.   |           |        | Minor            | 2.5                  |
| Contrast ratio       | See note 1  |           |        | Minor            | 2.5                  |
| Response time        | See note 2  |           |        | Minor            | 2.5                  |
| Viewing angle        | See note 3  |           |        | Minor            | 2.5                  |

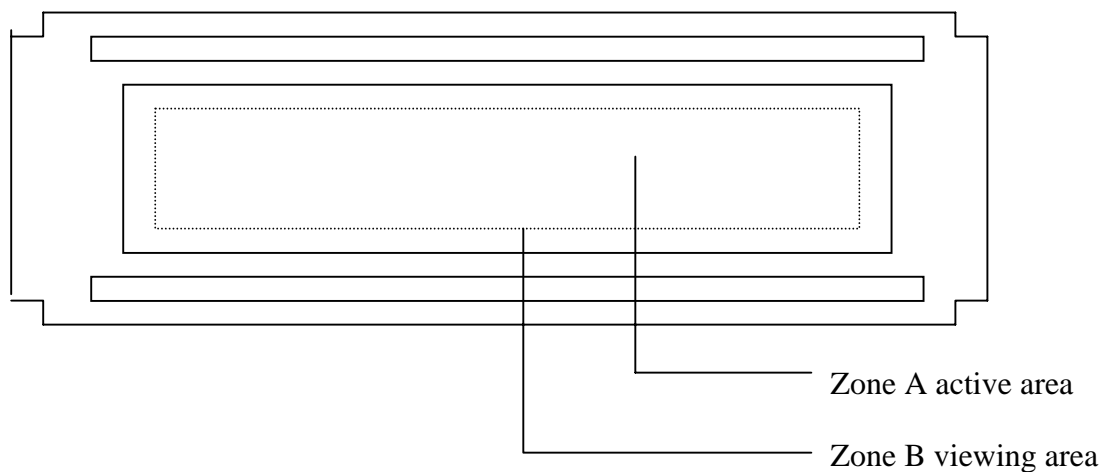

## 12.6 RELIABILITY

| Test Item                  | Test Conditions   | Note |
|----------------------------|---|------|
| High Temperature Operation | 70±3°C , t=96 hrs   |      |
| Low Temperature Operation  | -20±3°C , t=96 hrs  |      |
| High Temperature Storage   | 80±3°C , t=96 hrs   | 1,2  |
| Low Temperature Storage    | -30±3°C , t=96 hrs  | 1,2  |
| Temperature Cycle          | -30°C ~ 25°C ~ 80°C<br>30 m in. 5 min. 30 min. ( 1 cycle )<br>Total 5 cycle   | 1,2  |
| Humidity Test              | 40 °C, Humidity 90%, 96 hrs   | 1,2  |
| Vibration Test (Packing)   | Sweep frequency : 10 ~ 55 ~ 10 Hz/1min<br>Amplitude : 0.75mm<br>Test direction : X.Y.Z/3 axis<br>Duration : 30min/each axis | 2    |

Note 1 : Condensation of water is not permitted on the module.

Note 2 : The module should be inspected after 1 hour storage in normal conditions  
(15-35°C , 45-65%RH).

Definitions of life end point :

- Current drain should be smaller than the specific value.
- Function of the module should be maintained.
- Appearance and display quality should not have degraded noticeably.
- Contrast ratio should be greater than 50% of the initial value.

### **13 HANDLING PRECAUTIONS**

- (1) A LCD module is a fragile item and should not be subjected to strong mechanical shocks.
- (2) Avoid applying pressure to the module surface. This will distort the glass and cause a change in color.
- (3) Under no circumstances should the position of the bezel tabs or their shape be modified.
- (4) Do not modify the display PCB in either shape or positioning of components.
- (5) Do not modify or move location of the zebra or heat seal connectors.
- (6) The device should only be soldered to during interfacing. Modification to other areas of the board should not be carried out.
- (7) In the event of LCD breakage and resultant leakage of fluid do not inhale, ingest or make contact with the skin. If contact is made rinse immediately.
- (8) When cleaning the module use a soft damp cloth with a mild solvent, such as Isopropyl or Ethyl alcohol. The use of water, ketone or aromatic is not permitted.
- (9) Prior to initial power up input signals should not be applied.
- (10) Protect the module against static electricity and observe appropriate anti-static precautions.

# 14 OUTLINE DIMENSION

