



A Brighter Solution

AMP DISPLAY INC.

SPECIFICATIONS

+"\$! B '7 C @ C F '@ 8 TFT MODULE

CUSTOMER:	
CUSTOMER PART NO.	
AMP DISPLAY PART NO.	5 A !, \$\$ (, \$; HA E K ! \$ (< '
APPROVED BY:	
DATE:	

APPROVED FOR SPECIFICATIONS

APPROVED FOR SPECIFICATION AND PROTOTYPES

AMP DISPLAY INC

9856 SIXTH STREET RANCHO CUCAMONGA CA 91730
TEL: 909-980-13410 FAX: 909-980-1419
WWW.AMPDISPLAY.COM

Preliminary

The contents of this document are confidential and must not be disclosed wholly or in part to any third part without the prior written consent of AMP DISPLAY

RECORD OF REVISION

Revision Date	Page	Contents	Editor
2008/09/08	-	New Release	JACK
2009/6/23	3,7	Correct LCM brightness to 550cd/m2.	Eric

Preliminary

The contents of this document are confidential and must not be disclosed wholly or in part to any third part without the prior written consent of AMP DISPLAY

1. INTRODUCTION

Ampire Display Module AM800480E3 is a color active matrix TFT-LCD that uses amorphous silicon TFT as a switching device. This model is composed of a TFT-LCD panel, This TFT-LCD has a high resolution (800(R.G.B) X 480) and can display up to 262,144 colors.

1-1. Features

- WVGA (16:9 diagonal) configuration
- Input interface voltage: 3.3V
- Data enable mode
- Build-in LED Driver IC

1-2. Applications

- Portable TV
- Car user DVD
- Industrial application
- HMI (Human machine interface)

2. PHYSICAL SPECIFICATIONS

Item	Specifications	unit
Display resolution(dot)	800RGB (W) x 480(H)	dots
Active area	152.4 (W) x 91.44 (H)	mm
Pixel pitch	0.1905 (W) x 0.1905 (H)	mm
Color configuration	R.G.B Vertical stripe	
Overall dimension	165.0(W)x104.0(H)	mm
Weight	123.0 ± 1.0	g
Brightness	550 nit(typ)	cd/m ²
Contrast ratio	250 : 1	
Backlight unit	LED	
Display color	262,144	colors

Preliminary

The contents of this document are confidential and must not be disclosed wholly or in part to any third part without the prior written consent of AMP DISPLAY

3. ABSOLUTE MAX. RATINGS

ITEM	SYMBOL	MIN	MAX	UNIT
Power Supply Voltage for LCD	Vcc	-0.5	5.0	V
Signal input voltage	DCLK DE R0~R5 G0~G5 B0~b5	-0.5	VCC+0.5	V
Operation Temperature	Top	-10	70	°C
Storage Temperature	Tstg	-20	80	°C

The following values are maximum operation conditions, if exceeded; it may cause faulty operation or damage

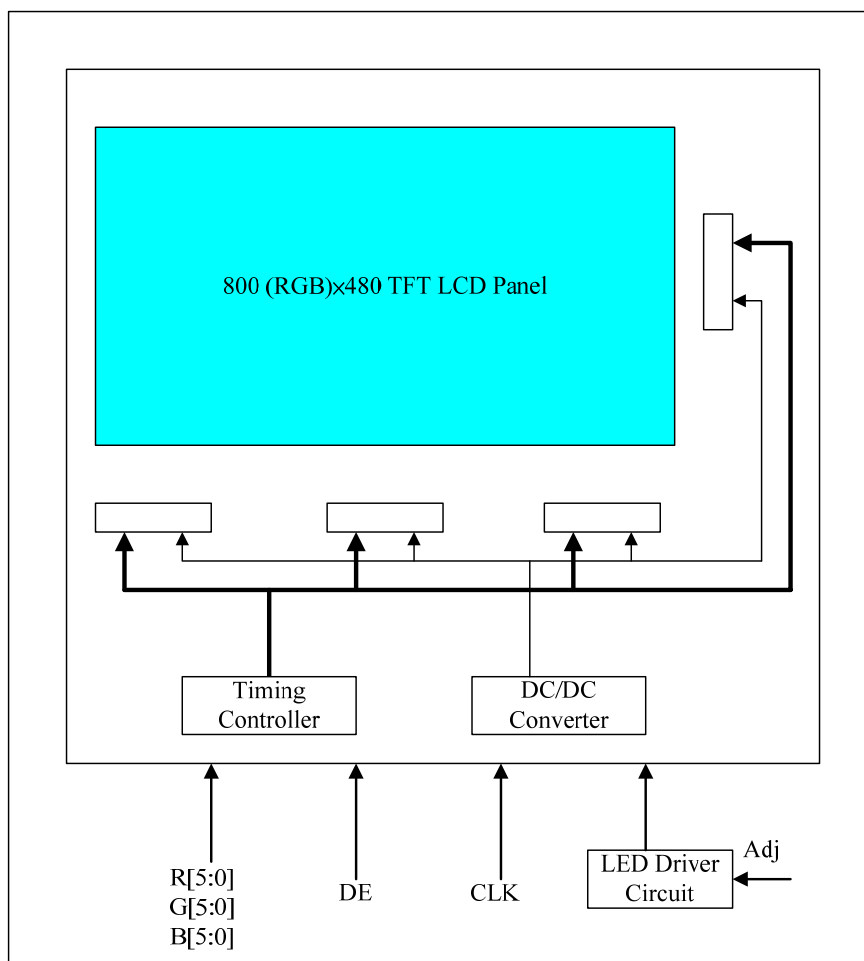

Preliminary

The contents of this document are confidential and must not be disclosed wholly or in part to any third part without the prior written consent of AMP DISPLAY

4. ELECTRICAL CHARACTERISTICS

4-1 TFT LCD Module voltage

ITEM	SYMBOL	MIN	TYP	MAX	UNIT	Remark	
Power Supply Voltage For LCD	V _{cc}	3.0	3.3	4.0	V	-	
Power Supply Current For LCD	I _{cc}	200	250	300	mA	-	
Power Supply Voltage For LED	V _{DD}	3	5	5.5	V	-	
Power Supply Current For LED	I _{DD}	-	460	-	mA	V _{DD} =3.3; Efficiency of LED Driver IC is 75%	
		-	310	-	mA	V _{DD} =5.0; Efficiency of LED Driver IC is 75%.	
Logic Input Voltage	Input Voltage	V _{IN}	0	-	V _{cc}	V	-
	Threshold Voltage(High)	V _{TH}	3.0	-	V _{cc}	V	-
	Threshold Voltage(Low)	V _{TL}	GND	-	0.5	V	-

VCC -dip codition:

- 1) When $2.7\text{ V} \leq V_{CC} < 3.0\text{ V}$, $t_d \leq 10\text{ ms}$.
- 2) $V_{CC} > 3.0\text{ V}$, VCC-dip condition should be same as VCC-turn-on condition.

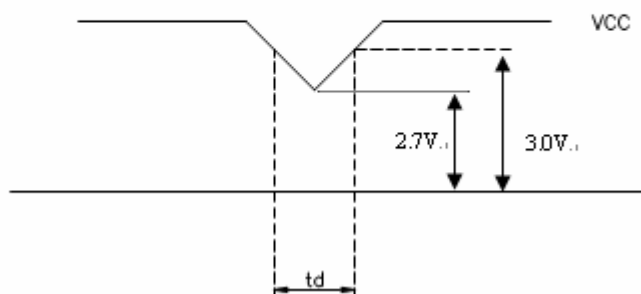

Preliminary

The contents of this document are confidential and must not be disclosed wholly or in part to any third part without the prior written consent of AMP DISPLAY

5. INTERFACE

Pin no	Symbol	Function
1	GND	Ground
2	GND	Ground
3	ADJ	Brightness control for LED B/L
4	VDD	Power supply for LED Driver circuit
5		
6		
7	VCC	Power supply (3.3V)
8		
9	DE	Data Enable Timing Signal
10	GND	Ground
11	GND	Ground
12	GND	Ground
13	B5	Blue data (MSB)
14	B4	Blue data
15	B3	Blue data
16	GND	Ground
17	B2	Blue data
18	B1	Blue data
19	B0	Blue data (LSB)
20	GND	Ground
21	G5	Green data (MSB)
22	G4	Green data
23	G3	Green data
24	GND	Ground
25	G2	Green data
26	G1	Green data
27	G0	Green data (LSB)
28	GND	Ground
29	R5	Red data (MSB)
30	R4	Red data
31	R3	Red data
32	GND	Ground
33	R2	Red data
34	R1	Red data
35	R0	Red data (LSB)
36	GND	Ground
37	GND	Ground
38	DCLK	Data Clock
39	GND	Ground
40	GND	Ground

Preliminary

The contents of this document are confidential and must not be disclosed wholly or in part to any third part without the prior written consent of AMP DISPLAY

6. OPTICAL CHARACTERISTICS

Item		Symbol	Condition	Min.	Typ.	Max.	Unit	Note
Response Time		$T_r + T_f$	$\Theta = \Phi = 0^\circ$	-	20	30	ms	(1)
Contrast ratio		CR				250		
Viewing Angle	Vertical	Θ	$CR \geq 10$		120			(5)
	Horizontal	Φ			140			
Luminance		L	$\Theta = \Phi = 0^\circ$		550			(3)(4)
Color chromaticity	Red	Rx	$\Theta = \Phi = 0^\circ$	0.551	0.581	0.611		(3)
		Ry		0.331	0.361	0.391		
	Green	Gx		0.324	0.354	0.384		
		Gy		0.534	0.564	0.594		
	Blue	Bx		0.118	0.148	0.178		
		By		0.094	0.124	0.154		
	White	Wx		0.287	0.317	0.347		
		Wy		0.325	0.355	0.385		

NOTE:

- These items are measured by BM-7(TOPCON) in the dark room (no ambient light)

(1) Definition of Response Time (White-Black)

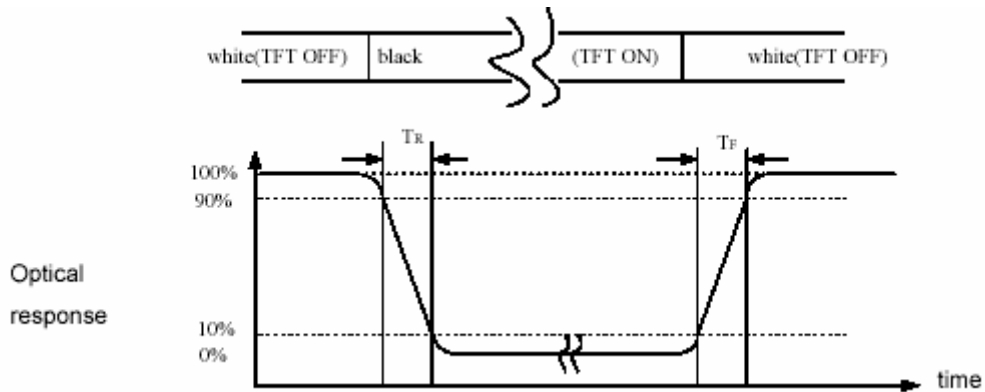

(2) Definition of Contrast Ratio

Measure contrast ratio on the below 5 points (refer to figure1, #1~#5point) and take the average value

Contrast ratio is calculated with the following formula:

Contrast Ratio(CR)=(White)Luminance of ON ÷ (Black)Luminance of OFF

Preliminary

The contents of this document are confidential and must not be disclosed wholly or in part to any third part without the prior written consent of AMP DISPLAY

(3) Definition of Luminance :

Measure white luminance on the same 5 points and take the average value

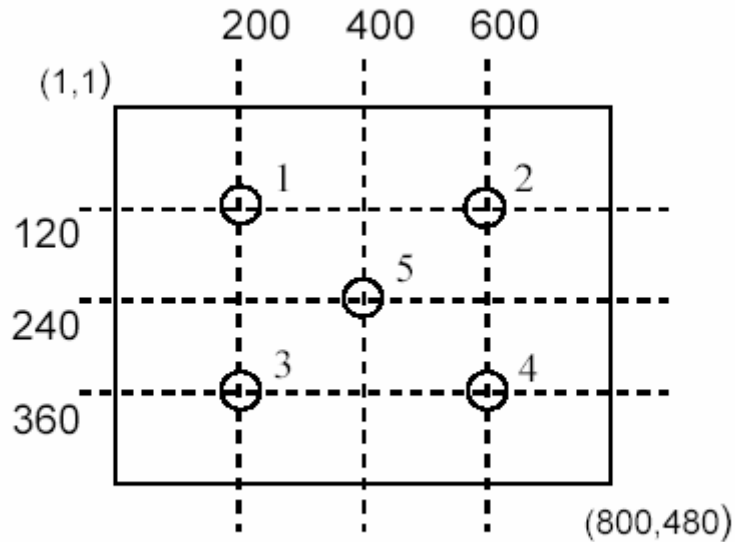

Fig.1 Measuring point

(1) Definition of Luminance Uniformity :

Measured Maximum luminance[L(MAX)] and Minimum luminance[L(MIN)] on the 5 points

Luminance Uniformity is calculated with the following formula:

$$\Delta L = [L(\text{MAX}) / L(\text{MIN}) - 1] \times 100$$

(2) Definition of Viewing Angle

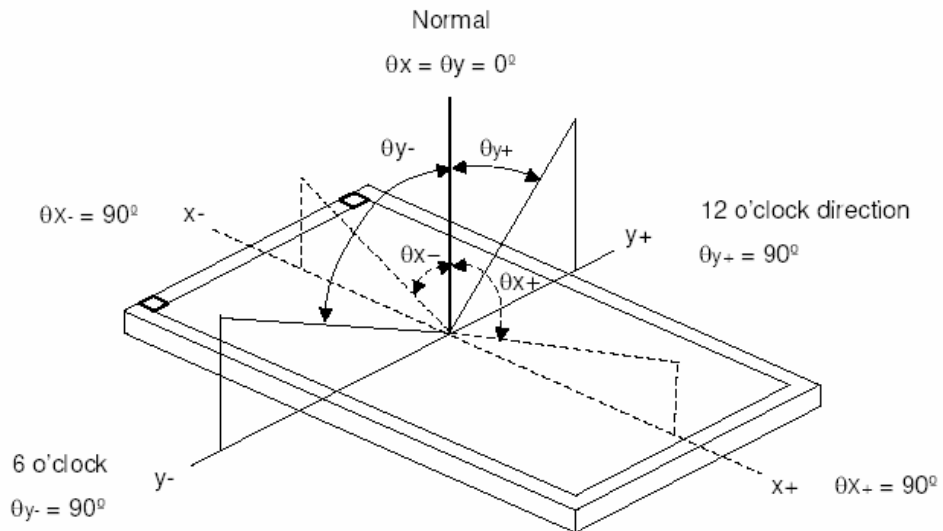

$$\Phi = (\theta_{x+}) + (\theta_{x-}) \quad \Theta = (\theta_{y+}) + (\theta_{y-})$$

Preliminary

The contents of this document are confidential and must not be disclosed wholly or in part to any third part without the prior written consent of AMP DISPLAY

7. INPUT SIGNAL (DE ONLY MODE)**Timing Characteristics**

WVGA mode (800x480)

Signal	Item	Symbol	Min	Type	Max	Unit
Clock Frequency	1/tclk	1/tclk	25	37	50	Mhz
Vertical Section	Period	Tv	481	513	1023	Th
	Active	Tdisp(v)	480	480	480	Th
Horizontal Section	Period	Th	832	900	1054	Tclk
	Active	Tdisp(h)	800	800	800	Tclk

Preliminary

The contents of this document are confidential and must not be disclosed wholly or in part to any third part without the prior written consent of AMP DISPLAY

8. QUALITY AND RELIABILITY

8.1 TEST CONDITIONS

Tests should be conducted under the following conditions:

Ambient temperature: $25 \pm 5^{\circ}\text{C}$

Humidity : $60 \pm 25\% \text{ RH}$.

8.2 SAMPLING PLAN

Sampling method shall be in accordance with MIL-STD-105E, level II, normal single sampling plan.

8.3 ACCEPTABLE QUALITY LEVEL

A major defect is defined as one that could cause failure to or materially reduce the usability of the unit for its intended purpose. A minor defect is one that does not materially reduce the usability of the unit for its intended purpose or is an infringement from established standards and has no significant bearing on its effective use or operation.

8.4 APPEARANCE

An appearance test should be conducted by human sight at approximately 30 cm distance from the LCD module under florescent light. The inspection area of LCD panel shall be within the range of following limits.

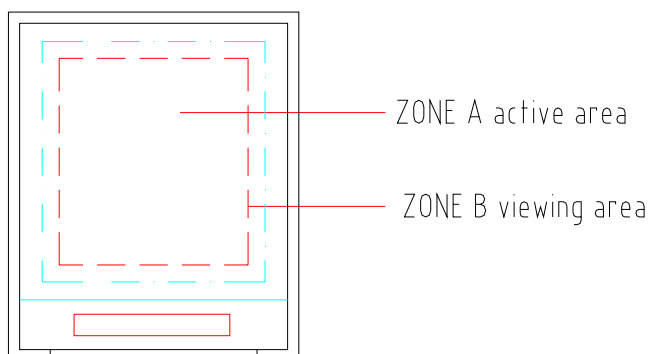

Preliminary

The contents of this document are confidential and must not be disclosed wholly or in part to any third part without the prior written consent of AMP DISPLAY

8.5 INCOMING INSPECTION STANDARD FOR TFT-LCD PANEL

DEFECT TYPE			LIMIT			Note		
VISUAL DEFECT	INTERNAL	SPOT	$\varphi < 0.15\text{mm}$		Ignore	Note1		
			$0.15\text{mm} \leq \varphi \leq 0.5\text{mm}$		$N \leq 4$			
			$0.5\text{mm} < \varphi$		$N=0$			
		FIBER	$0.03\text{mm} < W \leq 0.1\text{mm}, L \leq 5\text{mm}$		$N \leq 3$	Note1		
			$1.0\text{mm} < W, 1.5\text{mm} < L$		$N=0$			
		POLARIZER BUBBLE	$\varphi < 0.15\text{mm}$		Ignore	Note1		
			$0.15\text{mm} \leq \varphi \leq 0.5\text{mm}$		$N \leq 2$			
			$0.5\text{mm} < \varphi$		$N=0$			
		Mura	It' OK if mura is slight visible through 6%ND filter					
ELECTRICAL DEFECT	BRIGHT DOT	A Grade			B Grade			
		C Area	O Area	Total	C Area	O Area	Total	Note3
	$N \leq 0$	$N \leq 2$	$N \leq 2$	$N \leq 2$	$N \leq 3$	$N \leq 5$	Note2	
	DARK DOT	$N \leq 2$	$N \leq 3$	$N \leq 3$	$N \leq 3$	$N \leq 5$	$N \leq 8$	
	TOTAL DOT	$N \leq 4$			$N \leq 5$	$N \leq 6$	$N \leq 8$	Note2
	TWO ADJACENT DOT	$N \leq 0$	$N \leq 1$ pair	$N \leq 1$ pair	$N \leq 1$ pair	$N \leq 1$ pair	$N \leq 1$ pair	Note4
	THREE OR MORE ADJACENT DOT	NOT ALLOWED						
LINE DEFECT	NOT ALLOWED							

(1) One pixel consists of 3 sub-pixels, including R,G, and B dot.(Sub-pixel = Dot)

(2) LITTLE BRIGHT DOT $N \leq 10$ at 5% ND-Filter

[Note1] W : Width[mm], L : Length[mm], N : Number, φ : Average Diameter

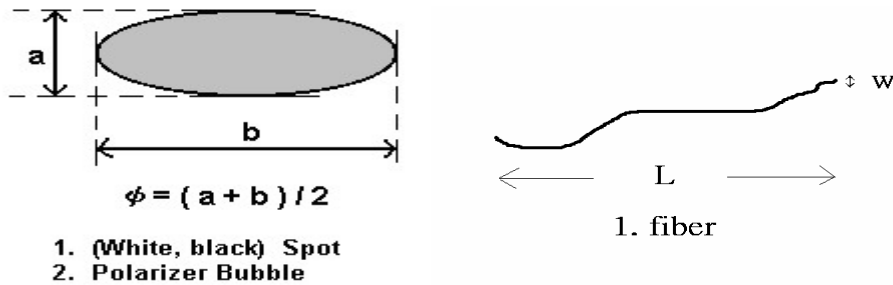

[Note2] Bright dot is defined through 5% transmission ND Filter as following.

Preliminary

The contents of this document are confidential and must not be disclosed wholly or in part to any third part without the prior written consent of AMP DISPLAY

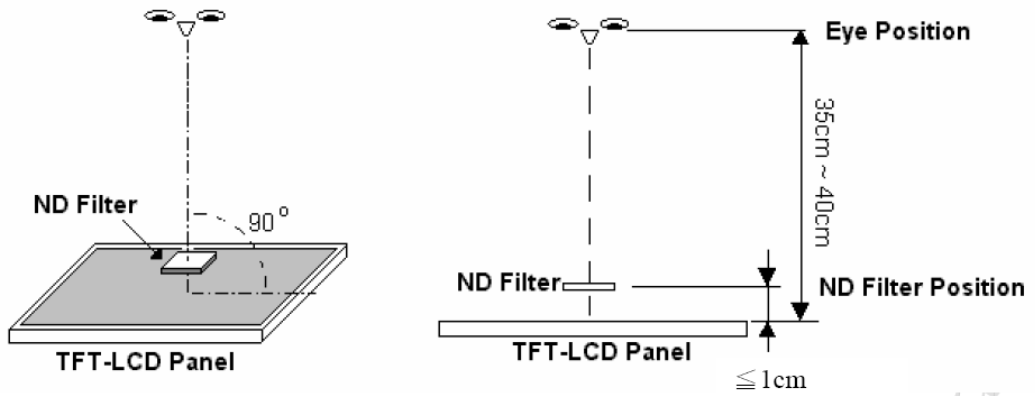

[Note3]

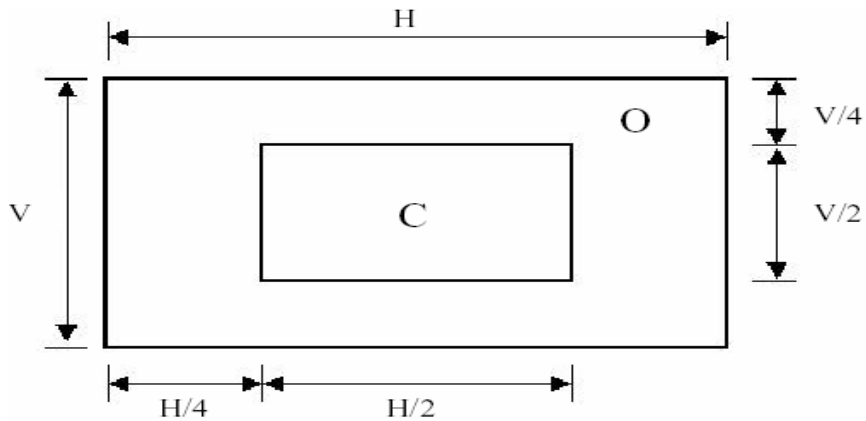

C Area: Center of display area

O Area: Outer of display area

[Note4]

Judge defect dot and adjacent dot as following. Allow below (as A, B, C and D status) adjacent defect dots, including bright and dark adjacent dot. And they will be counted 2 defect dots in total quantity.

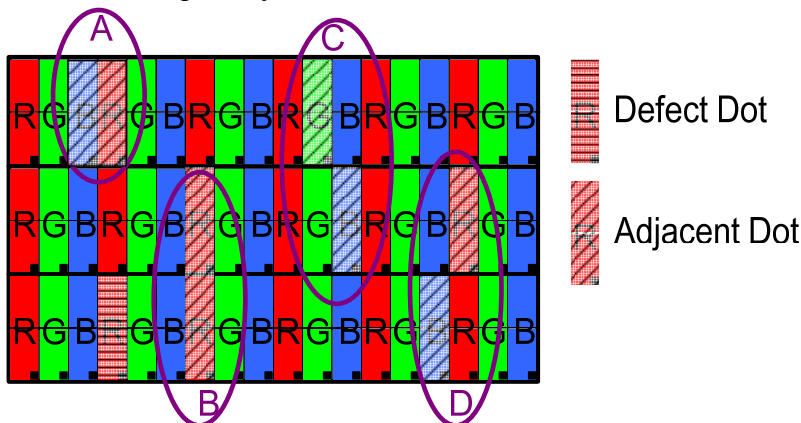

- (1) The defects that are not defined above and considered to be problem shall be reviewed and discussed by both parties.
- (2) Defects on the Black Matrix, out of Display area, are not considered as a defect or counted.

Preliminary

The contents of this document are confidential and must not be disclosed wholly or in part to any third part without the prior written consent of AMP DISPLAY

8.6 RELIABILITY TEST CONDITIONS

ITEM	CONDITIONS	NOTE
HIGH TEMPERATURE OPERATION	60°C , 240Hrs	
HIGH TEMPERATURE AND HIGH HUMIDITY OPERATION	40°C , 90%RH , 240Hrs	
HIGH TEMPERATURE AND HIGH HUMIDITY STORAGE	60°C , 90%RH , 48 Hrs	
HIGH TEMPERATURE STORAGE	70°C , 240Hrs	
LOW TEMPERATURE OPERATION	-10°C , 240Hrs	
LOW TEMPERATURE STORAGE	-20°C , 240Hrs	
THERMAL SHOCK (No operation)	-20°C(0.5Hr) ~60°C(0.5Hr) 200Cycle	
ESD	±8kV&±15kV air & contact test	(1)
	0Ω,±200V contact test	(2)

NOTE: Measure point:

(1) LCD glass and bezel

(2) IF connector pins

Preliminary

The contents of this document are confidential and must not be disclosed wholly or in part to any third part without the prior written consent of AMP DISPLAY

9. USE PRECAUTIONS

9-1 Handling precautions

(1) The polarizing plate may break easily so be careful when handling it. Do not touch, press or rub it with a hard-material tool like tweezers.

(2) Do not touch the polarizing plate surface with bare hands so as not to make it dirty. If the surface or other related part of the polarizing plate is dirty, soak a soft cotton cloth or chamois leather in benzine and wipe off with it. Do not use chemical liquids such as acetone, toluene and isopropyl alcohol. Failure to do so may bring chemical reaction phenomena and deteriorations.

(3) Remove any spit or water immediately. If it is left for hours, the suffered part may deform or decolorize.

(1) If the LCD element breaks and any LC stuff leaks, do not suck or lick it. Also if LC stuff is stuck on your skin or clothing, wash thoroughly with soap and water immediately.

9-2 Installing precautions

(1) The PCB has many ICs that may be damaged easily by static electricity. To prevent breaking by static electricity from the human body and clothing, earth the human body properly using the high resistance and discharge static electricity during the operation. In this case, however, the resistance value should be approx. $1M\Omega$ and the resistance should be placed near the human body rather than the ground surface. When the indoor space is dry, static electricity may occur easily so be careful. We recommend the indoor space should be kept with humidity of 60% or more. When a soldering iron or other similar tool is used for assembly, be sure to earth it.

(2) When installing the module and ICs, do not bend or twist them. Failure to do so may crack LC element and cause circuit failure.

(3) To protect LC element, especially polarizing plate, use a transparent protective plate (e.g., acrylic plate, glass etc) for the product case.

(4) Do not use an adhesive like a both-side adhesive tape to make LCD surface (polarizing plate) and product case stick together. Failure to do so may cause the polarizing plate to peel off

9-3 Storage precautions

(1) Avoid a high temperature and humidity area. Keep the temperature between 0°C and 35°C and also the humidity under 60%.

(2) Choose the dark spaces where the product is not exposed to direct sunlight or fluorescent light.

(3) Store the products as they are put in the boxes provided from us or in the same conditions as we recommend.

Preliminary

The contents of this document are confidential and must not be disclosed wholly or in part to any third part without the prior written consent of AMP DISPLAY

9-4 Operating precautions

(1) Do not boost the applied drive voltage abnormally. Failure to do so may break ICs. When applying power voltage, check the electrical features beforehand and be careful. Always turn off the power to the LC module controller before removing or inserting the LC module input connector. If the input connector is removed or inserted while the power is turned on, the LC module internal circuit may break.

(2) The display response may be late if the operating temperature is under the normal standard, and the display may be out of order if it is above the normal standard. But this is not a failure; this will be restored if it is within the normal standard.

(3) The LCD contrast varies depending on the visual angle, ambient temperature, power voltage etc. Obtain the optimum contrast by adjusting the LC drive voltage.

(4) When carrying out the test, do not take the module out of the low-temperature space suddenly. Failure to do so will cause the module condensing, leading to malfunctions.

(5) Make certain that each signal noise level is within the standard (L level: $0.2V_{dd}$ or less and H level: $0.8V_{dd}$ or more) even if the module has functioned properly. If it is beyond the standard, the module may often malfunction. In addition, always connect the module when making noise level measurements.

(6) The CMOS ICs are incorporated in the module and the pull-up and pull-down function is not adopted for the input so avoid putting the input signal open while the power is ON.

(7) The characteristic of the semiconductor element changes when it is exposed to light emissions, therefore ICs on the LCD may malfunction if they receive light emissions. To prevent these malfunctions, design and assemble ICs so that they are shielded from light emissions.

(8) Crosstalk occurs because of characteristics of the LCD. In general, crosstalk occurs when the regularized display is maintained. Also, crosstalk is affected by the LC drive voltage. Design the contents of the display, considering crosstalk.

9-5 Other

(1) Do not disassemble or take the LC module into pieces. The LC modules once disassembled or taken into pieces are not the guarantee articles.

(2) The residual image may exist if the same display pattern is shown for hours. This residual image, however, disappears when another display pattern is shown or the drive is interrupted and left for a while. But this is not a problem on reliability.

(3) AMIPRE will provide one year warrantee for all products and three months warrantee for all repairing products.

Preliminary

The contents of this document are confidential and must not be disclosed wholly or in part to any third part without the prior written consent of AMPIRE CO., LTD

10. Packing Drawing

REV. REVISION RECORD		DATE NAME
0	NEW RELEASE	06-04-07 EMILY
1	增加適用機種	11-20-09 EMILY

適用機種：
 480234C 系列
 480234G-CW/G-CW-T 系列
 480234G-QW 系列
 480234G1-CW 系列
 800480E2/E2-T 系列
 800480E3/E3-T 系列

AMPIRE 晶采光電科技
TITLE 480234G
 (7.0")
DWG. NO. *O70605SB
SHEET 1 OF 1

DATE 06-04-07
DATE
DATE

	TOLERANCE GRADE(±)	A	B	DIM.	MM	CHK.	DWG.	EMILY	DATE
7	~6	0.05	0.1						
8		0.08	0.18						
9	6~18	0.1	0.25						
10	18~50	0.2	0.4						
11	50~180	0.3	0.5						
12	180~								

PARTS NO. BOX-1 APPD. 480234G
DATE

Note:
 1層 15x2 LCM = 30pcs LCM
 1箱 2層 30x2 = 60pcs LCM

Preliminary

The contents of this document are confidential and must not be disclosed wholly or in part to any third part without the prior written consent of AMPIRE CO., LTD

11. OUTLINE DIMENSION

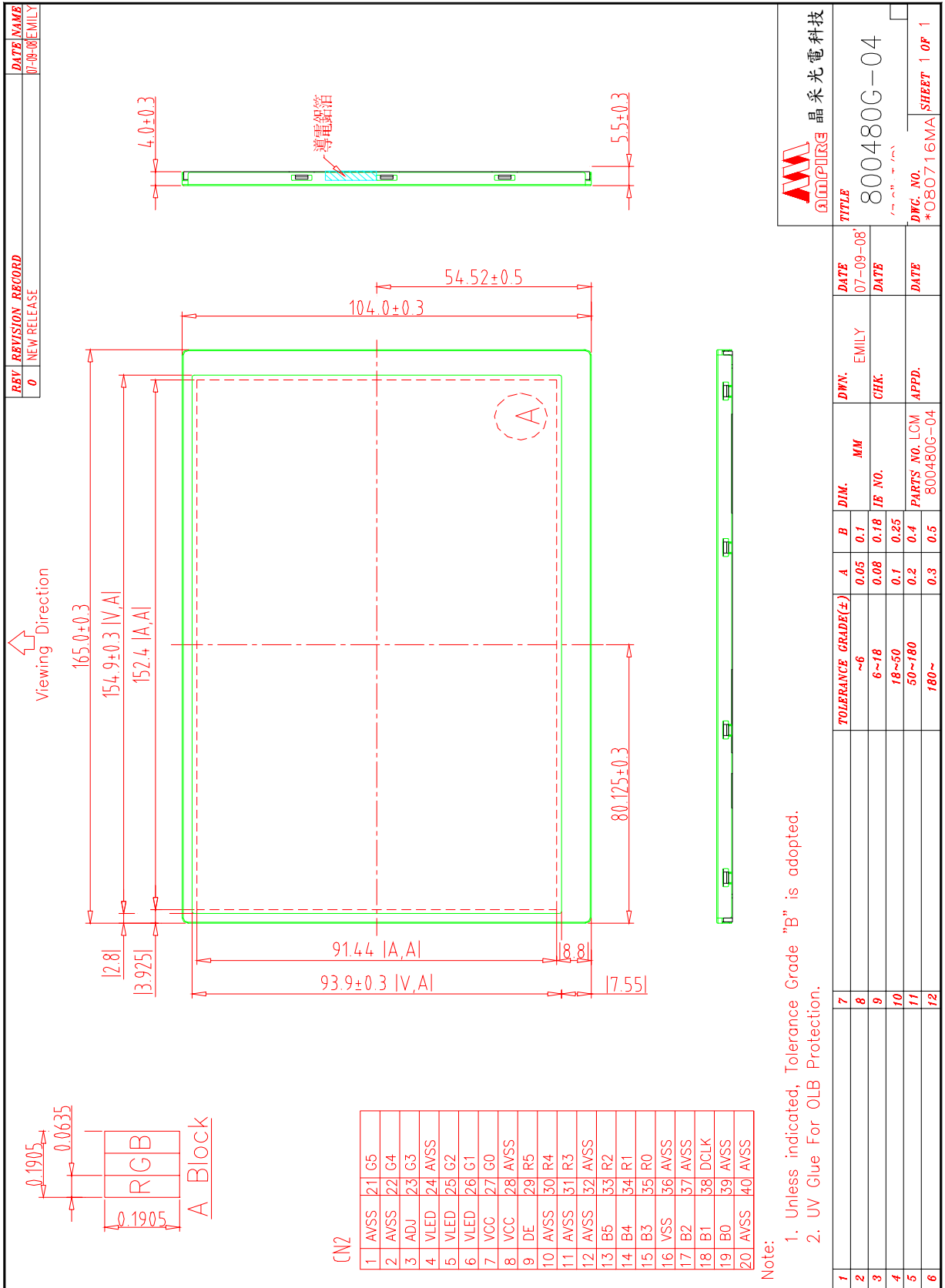

Note:
 1. Unless indicated, Tolerance Grade "B" is adopted.
 2. UV Glue For OLB Protection.

Preliminary

The contents of this document are confidential and must not be disclosed wholly or in part to any third part without the prior written consent of AMPIRE CO., LTD

