



A Brighter Solution

# AMP DISPLAY INC.

## SPECIFICATIONS

### 5 A !, \$\$ ( , \$9 ( HA E K ' ! \$ & < ' FIGMB 7 ' a c X Y L ' TFT MODULE

CUSTOMER:	
CUSTOMER PART NO.	
AMP DISPLAY PART NO.	5 A !, \$\$ ( , \$9 ( HA E K ' ! \$ & < ' FIGMB 7 ' a c X Y L '
APPROVED BY:	
DATE:	

APPROVED FOR SPECIFICATIONS

APPROVED FOR SPECIFICATION AND PROTOTYPES

## AMP DISPLAY INC

9856 SIXTH STREET RANCHO CUCAMONGA CA 91730  
TEL: 909-980-13410 FAX: 909-980-1419  
WWW.AMPDISPLAY.COM

## RECORD OF REVISION

Revision Date	Page	Contents	Editor
2009/08/04	--	New Release	Emil

## 1. INTRODUCTION

Ampire Display Module AM800480E4 is a color active matrix TFT-LCD that uses amorphous silicon TFT as a switching device . This model is composed of a TFT-LCD panel ,This TFT-LCD has a high resolution (800(R.G.B) X 480) and can display up to 262,144 colors .

### 1-1. Features

- 7" WVGA (16:9 diagonal) configuration
- Input interface voltage : 3.3V
- SYNCmode

### 1-2. Applications

- Portable TV
- Car use DVD
- Industrial application
- HMI (Human machine interface)

## 2. PHYSICAL SPECIFICATIONS

Item	Specifications	unit
Display resolution(dot)	800RGB (W) x 480(H)	dots
Active area	152.4 (W) x 91.44 (H)	mm
Pixel pitch	0.1905 (W) x 0.1905 (H)	mm
Color configuration	R.G.B Vertical stripe	
Overall dimension	165.0(W)x104.0(H)x8.4 max(T)	mm
Weight	123.0 ± 1.0	g
Brightness	400 nit(typ)	cd/m <sup>2</sup>
Contrast ratio	250 : 1	
Backlight unit	LED	
Display color	262,144	colors

### 3. ABSOLUTE MAX. RATINGS

ITEM	SYMBOL	MIN	MAX	UNIT
Power Supply Voltage for LCD	Vcc	-0.5	5.0	V
Signal input voltage	DCLK DE HSYNC VSYNC R0~R5 G0~G5 B0~b5	-0.5	VCC+0.5	V
Operation Temperature	Top	-10	60	°C
Storage Temperature	Tstg	-20	70	°C

The following values are maximum operation conditions, If exceeded, it may cause faulty operation or damage

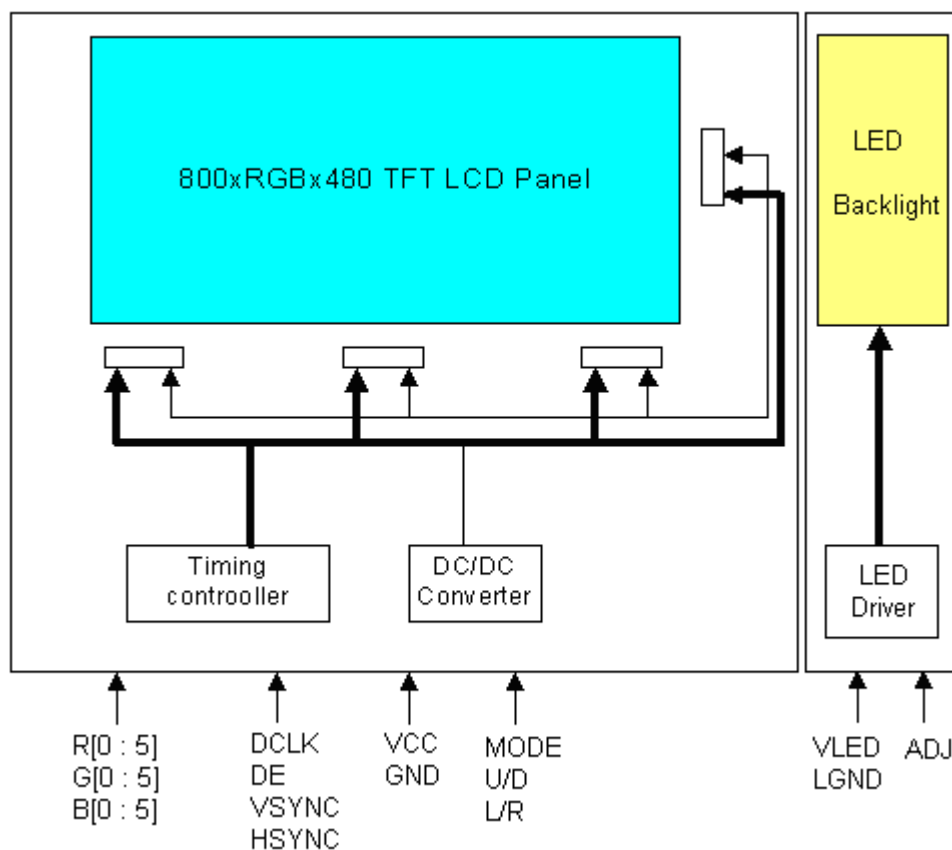

## 4. ELECTRICAL CHARACTERISTICS

### 4-1 TFT LCD Module voltage

ITEM	SYMBOL	MIN	TYP	MAX	UNIT	CONDITION
Power Supply Voltage For LCD	V <sub>CC</sub>	3.0	3.3	4.0	V	
Power Supply Current For LCD	I <sub>CC</sub>	170	210	250	mA	V <sub>CC</sub> =3.3V
Power Supply Voltage For LED	V <sub>LED</sub>	4.5	5.0	5.5	V	
Power Supply Current For LED	I <sub>LED</sub>	-	390	420	mA	V <sub>LED</sub> =5V V <sub>ADJ</sub> =3.3V (duty 100%)
LED Backlight Voltage	V <sub>BL</sub>	-	10.5	12	V	I <sub>BL</sub> =162mA
LED Backlight Current	I <sub>BL</sub>	-	162	180	mA	V <sub>LED</sub> =5V V <sub>ADJ</sub> =3.3V (duty 100%)
ADJ Input Voltage	V <sub>ADJ</sub>	-	3.3	-	V	duty=100%
Logic Input Voltage	Input Voltage	V <sub>IN</sub>	0	-	V <sub>CC</sub>	V
	Threshold Voltage(High)	V <sub>TH</sub>	3.0	-	V <sub>CC</sub>	V
	Threshold Voltage(Low)	V <sub>TL</sub>	GND	-	0.5	V

Note 1:

VCC -dip codition:

- 1) When  $2.7\text{ V} \leq V_{CC} < 3.0\text{ V}$ ,  $t_d \leq 10\text{ ms}$ .
- 2)  $V_{CC} > 3.0\text{ V}$ , VCC-dip condition should be same as VCC-turn-on condition.

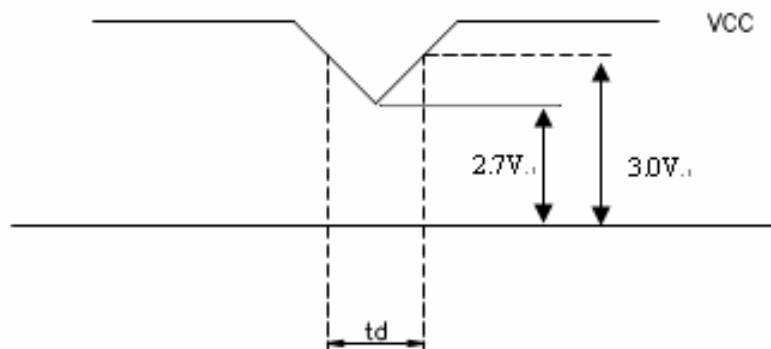

Note 2:

The constant current source is needed for white LED back-light driving.

When LCM is operated over 60°C ambient temperature, the I<sub>BL</sub> of the LED

back-light should be adjusted to 135mA max

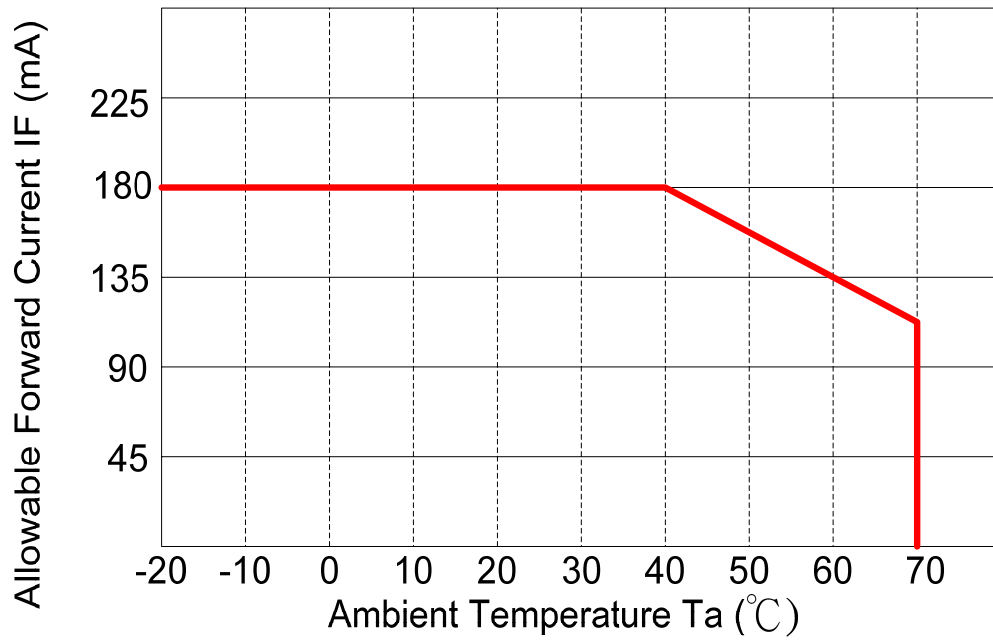

## 5. INTERFACE

Pin no	Symbol	Function	Note
1	VLED	Power supply for LED (5V)	
2	VLED	Power supply for LED (5V)	
3	ADJ	Adjust for LED Brightness	(1)
4	LGND	LED Driver Ground	
5	LGND	LED Driver Ground	
6	VCC	Power supply for LED (3.3V)	
7	VCC	Power supply for LCD (3.3V)	
8	MODE	DE or SYNC mode Select	(2)
9	DE	Data Enable Timing Signal	
10	VSYNC	Vsync signal input	
11	HSYNC	Hsync signal input	
12	GND	Ground	
13	B5	Blue data (MSB)	
14	B4	Blue data	
15	B3	Blue data	
16	GND	Ground	
17	B2	Blue data	
18	B1	Blue data	
19	B0	Blue data (LSB)	
20	GND	Ground	
21	G5	Green data (MSB)	
22	G4	Green data	
23	G3	Green data	
24	GND	Ground	
25	G2	Green data	
26	G1	Green data	
27	G0	Green data (LSB)	
28	GND	Ground	
29	R5	Red data (MSB)	
30	R4	Red data	
31	R3	Red data	
32	GND	Ground	
33	R2	Red data	
34	R1	Red data	
35	R0	Red data (LSB)	
36	GND	Ground	
37	DCLK	Data Clock	
38	NC	No Connection ( need to be floating )	
39	L/R	Select left or right scanning direction	(3)
40	U/D	Select up or down scanning direction	(3)

NOTE :

(1) Pin3: ADJ is PWM signal input. It is for brightness control.

ITEM	SYMBOL	MIN	TYP	MAX	UNIT
ADJ signal frequency	f <sub>PWM</sub>	100	--	1K	Hz
ADJ signal logic level High	VIH	2V	--	VLED (5.0V)	V
ADJ signal logic level Low	VIL	0	--	0.5	V

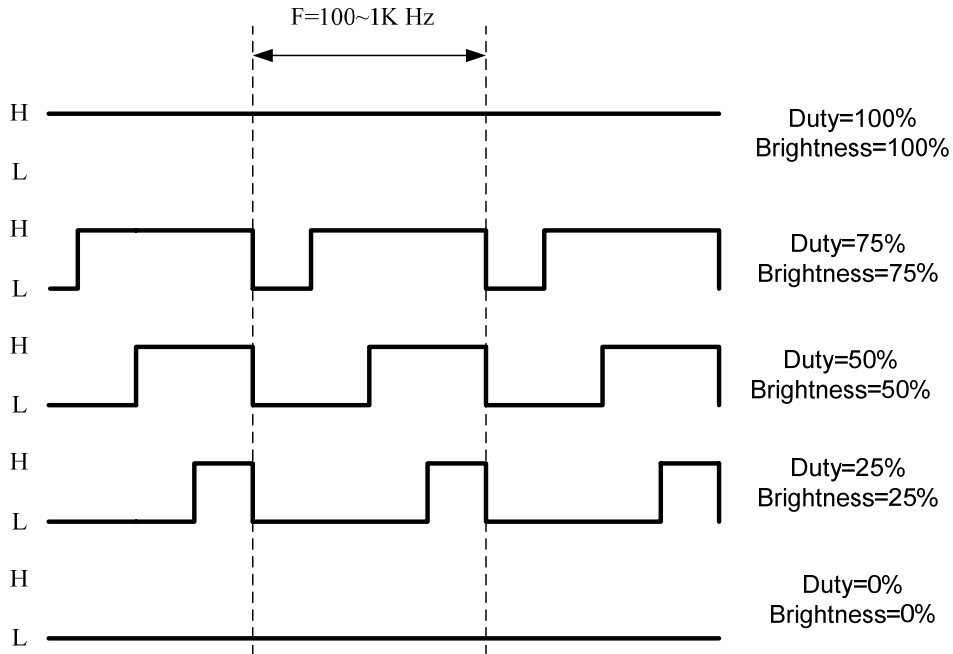

(2) DE Mode, Mode="H", HSYNC floating and VSYNC floating  
 HV Mode, Mode="L" and DE floating

(3) Selection of scanning mode

Setting of scan control input		Scanning direction
U/D	R/L	
GND	VCC	Up to Down, Left to Right
VCC	GND	Down to Up, Right to Left
GND	GND	Up to Down, Right to Left
VCC	VCC	Down to Up, Left to Right

## 6. OPTICAL CHARACTERISTICS

Item	Symbol	Condition	Min.	Typ.	Max.	Unit	Note
Response Time	$T_r + T_f$	$\Theta = \Phi = 0^\circ$	-	20	30	ms	(1)
Contrast ratio	CR			250			(2)(3)
Viewing Angle	Vertical	$\Theta$	$CR \geq 10$	120			(5)
	Horizontal	$\Phi$		140			
Luminance	L	$\Theta = \Phi = 0^\circ$		500			(3)(4)
Color chromaticity	Red	Rx	$\Theta = \Phi = 0^\circ$	0.541	0.581	0.621	(3)
		Ry		0.321	0.361	0.401	
	Green	Gx		0.314	0.354	0.394	
		Gy		0.524	0.564	0.604	
	Blue	Bx		0.108	0.148	0.188	
		By		0.084	0.124	0.164	
	White	Wx		0.277	0.317	0.357	
		Wy		0.315	0.355	0.395	

NOTE :

- These items are measured by BM-7(TOPCON) in the dark room (no ambient light)
- Brightness conditions : IL=180mA.

### (1) Definition of Response Time (White-Black)

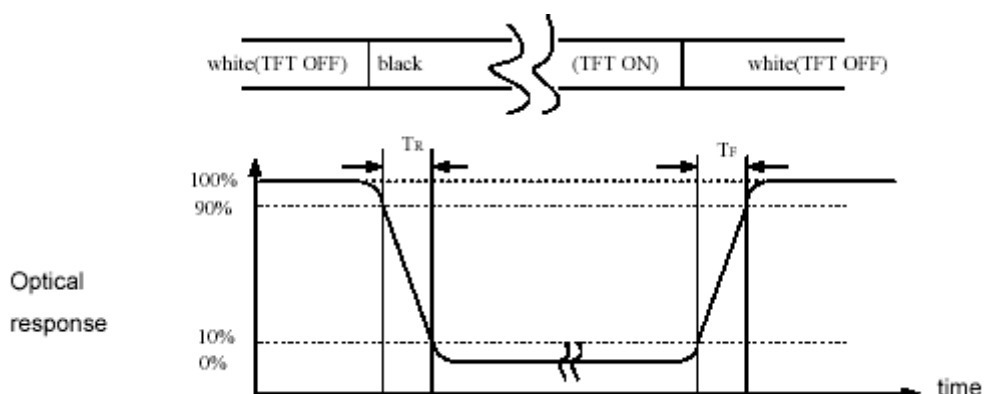

### (2) Definition of Contrast Ratio

Measure contrast ratio on the below 5 points(refer to figure,#1~#5point) and take the average value

Contrast ratio is calculated with the following formula :

$$\text{Contrast Ratio(CR)} = (\text{White})\text{Luminance of ON} \div (\text{Black})\text{Luminance of OFF}$$

(3) Definition of Luminance :

Measure white luminance on the same 5 points and take the average value

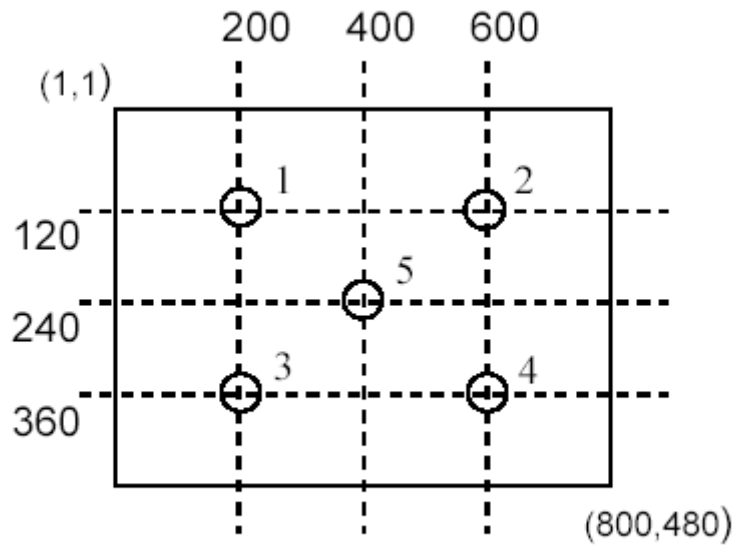

Fig.1 Measuring point

(1) Definition of Luminance Uniformity :

Measured Maximum luminance[L(MAX)] and Minimum luminance[L(MIN)] on the 5 points

Luminance Uniformity is calculated with the following formula :

$$\Delta L = [ L(\text{MAX}) / L(\text{MIN}) - 1 ] \times 100$$

(2) Definition of Viewing Angle

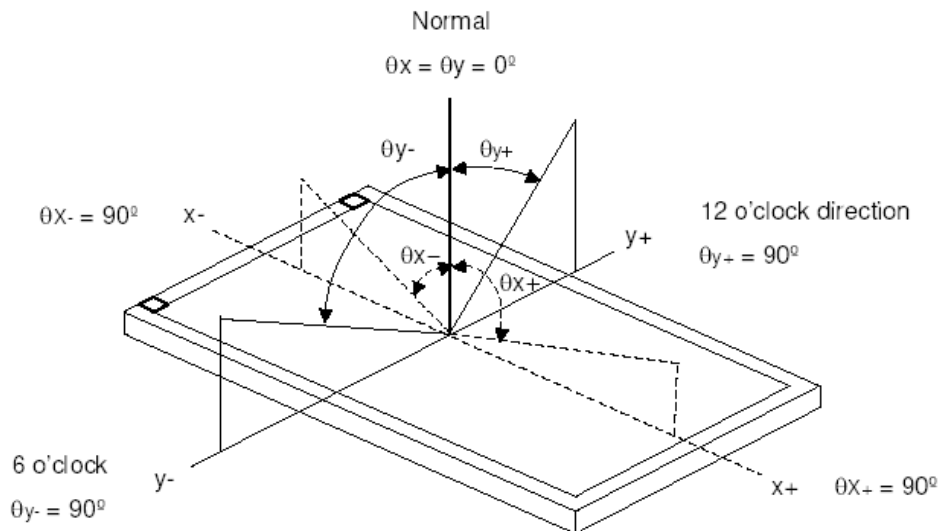

$$\Phi = (\Theta_{x+}) + (\Theta_{x-}) \quad \Theta = (\Theta_{y+}) + (\Theta_{y-})$$

## 7. TIMING CHARACTERISTICS

### DE only mode

DE mode Input signal characteristics, 800 x 480

PARAMETER	SYMBOL	MIN	TYP	MAX	UNIT	REMARK
DCLK	PERIOD	TCLK	25	34	-	NS
	FREQUENCY	FCLK	-	29.5	40	MHZ
	LOW LEVEL WIDTH	TWCL	6	-	-	NS
	HIGH LEVEL WIDTH	TWCH	6	-	-	NS
	RISE, FALL TIME	TCLKR, TCLKF	-	-	3	NS
	DUTY	-	0.45	0.50	0.55	-
DE	SETUP TIME	TDES	5	-	-	NS
	HOLD TIME	TDEH	5	-	-	NS
	RISE, FALL TIME	TDER, TDEF	-	-	5	NS
	HORIZONTAL PERIOD	THP	810	928	1600	TCLK
	HORIZONTAL VALID	THV	800			TCLK
	HORIZONTAL BLANK	THBK	THP - THV			TCLK
	VERTICAL PERIOD	TVP	485	525	960	THP
	VERTICAL VALID	TW	480			THP
VERTICAL BLANK	TVBK	TVP - TW			THP	
DATA	SETUP TIME	TDS	5	-	-	NS
	HOLD TIME	TDH	5	-	-	NS
	RISE, FALL TIME	TDR, TDF	-	-	3	NS

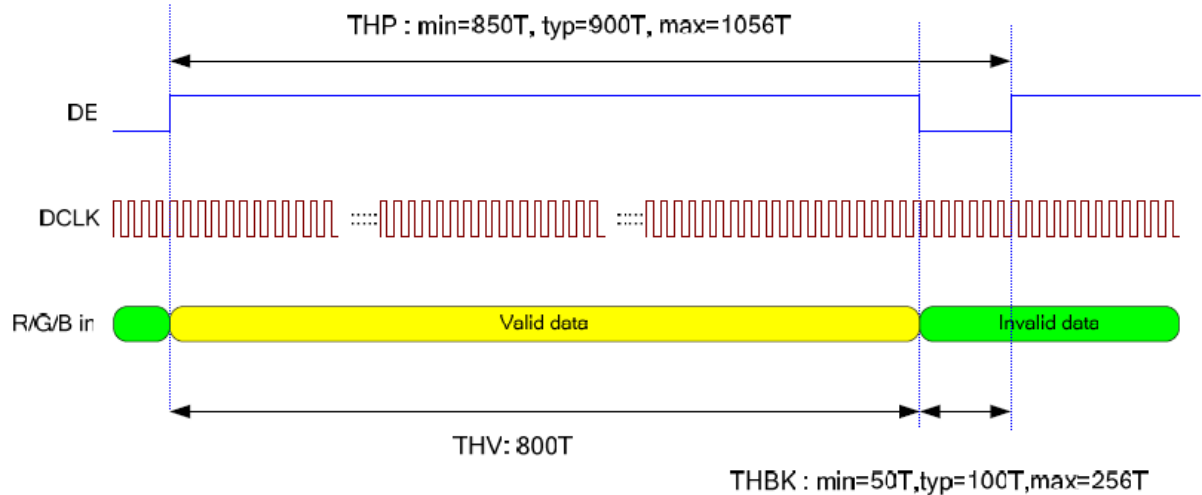
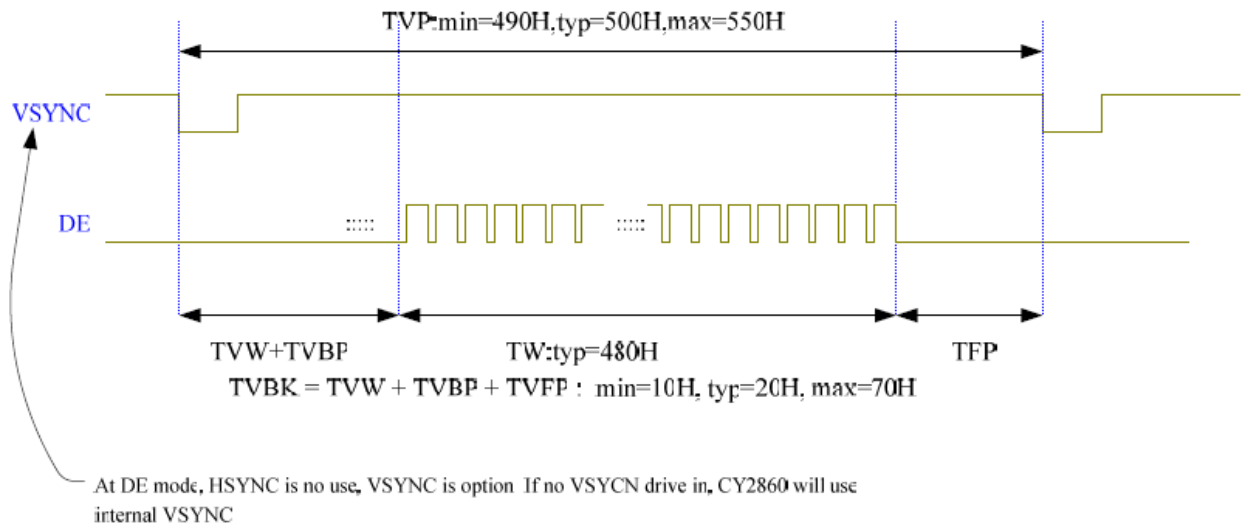

## SYNC mode

SYNC mode Input signal characteristic, 800 x 480

PARAMETER	SYMBOL	MIN.	TYP.	MAX.	UNIT	REMARK
CLOCK PERIOD	TCLK	25	34	-	NS	
CLOCK FREQUENCY	FCLK	-	29.5	40	MHZ	
CLOCK LOW LEVEL WIDTH	TWCL	8	-	-	NS	
CLOCK HIGH LEVEL WIDTH	TWCH	8	-	-	NS	
CLOCK RISE, FALL TIME	TCLKR, TCLKF	-	-	3	NS	
HSYNC PERIOD	THP	810	928	1600	TCLK	
HSYNC PULSE WIDTH	THW	-	48	-	TCLK	
HSYNC BACK PORCH	THBP	-	40	-	TCLK	
HSYNC WIDTH + BACK PORCH	THW+ THBP	88			TCLK	
HORIZONTAL VALID DATA WIDTH	THV	800			TCLK	
HSYNC FRONT PORCH	THFP	THP - THW - THBP - THV			TCLK	
HORIZONTAL BLANK	THBK	THP - THV			TCLK	
VSYNC PERIOD	TVP	485	525	960	THP	
VSYNC PULSE WIDTH	TVW	-	3	-	THP	
VSYNC BACK PORCH	TVBP	29			THP	
VERTICAL DATA VALID WIDTH	TW	480			THP	
VSYNC FRONT PORCH	TVFP	TVP - TVW - TVBP - TW			THP	
VERTICAL BLANK	TVBK	TVP - TW			THP	
DATA SETUP TIME	TDS	5	-	-	NS	
DATA HOLD TIME	TDH	5	-	-	NS	

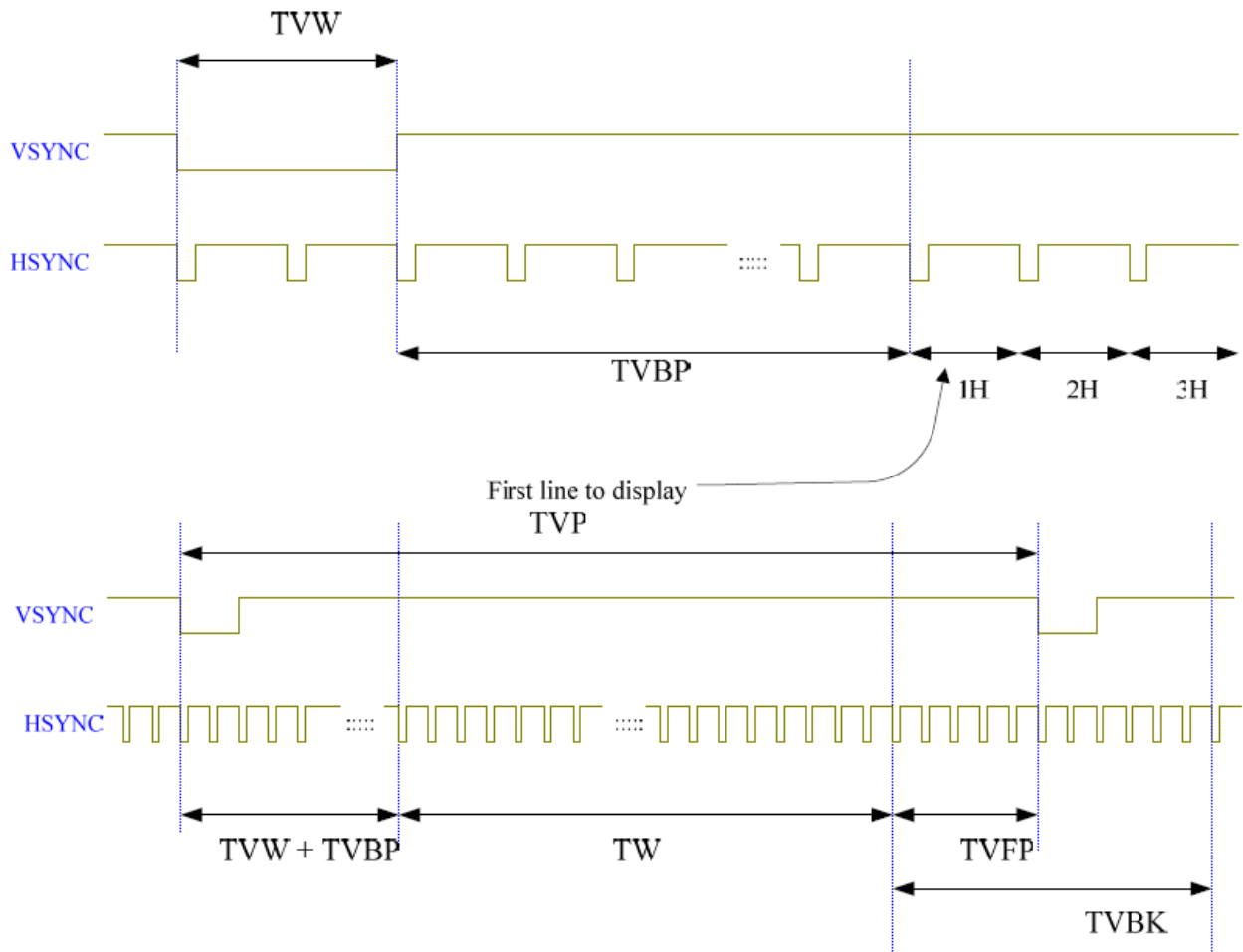

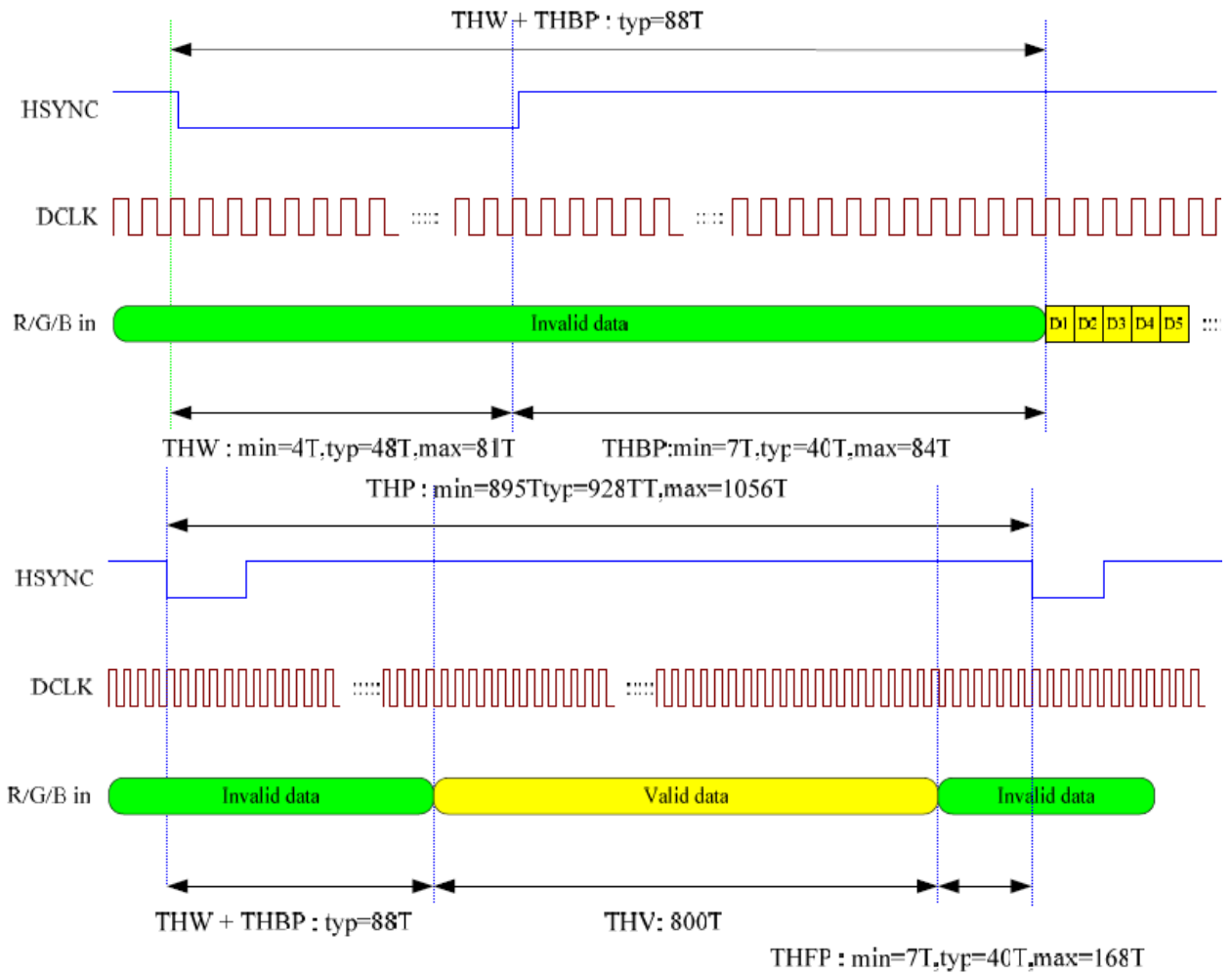

### Input clock, Setup/Hold time

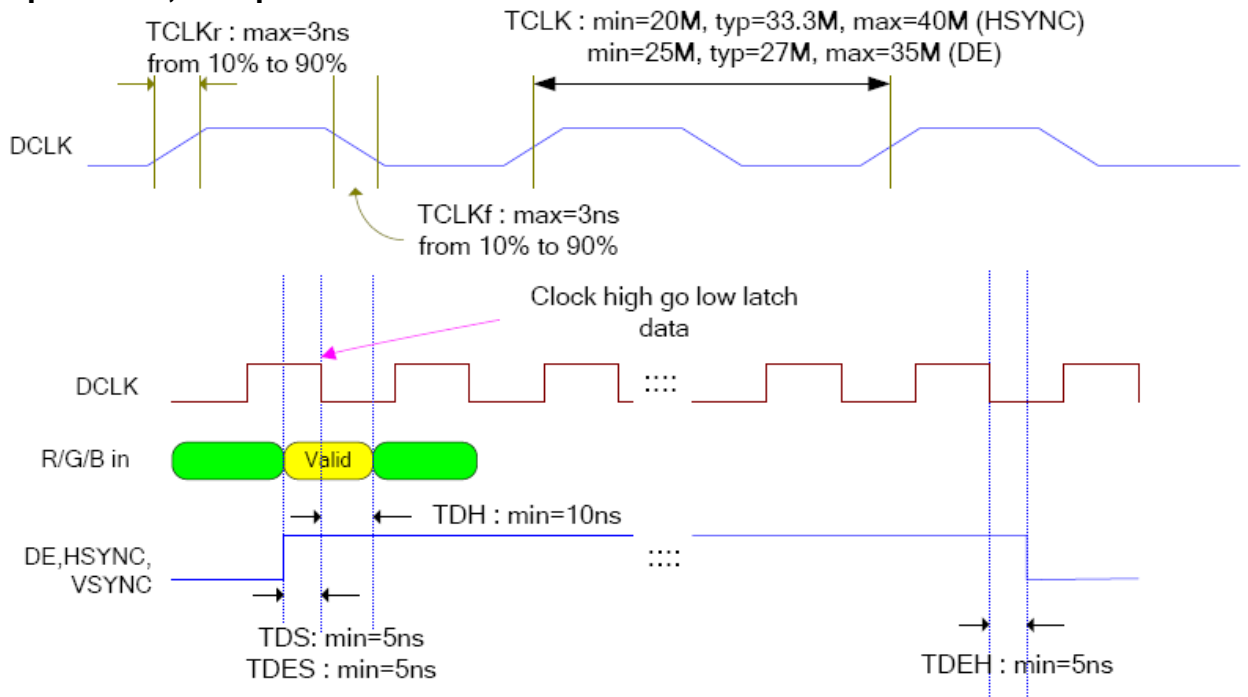

## 8. QUALITY AND RELIABILITY

### 8.1 TEST CONDITIONS

Tests should be conducted under the following conditions :

Ambient temperature :  $25 \pm 5^{\circ}\text{C}$

Humidity :  $60 \pm 25\% \text{ RH}$ .

### 8.2 SAMPLING PLAN

Sampling method shall be in accordance with MIL-STD-105E , level II, normal single sampling plan .

### 8.3 ACCEPTABLE QUALITY LEVEL

A major defect is defined as one that could cause failure to or materially reduce the usability of the unit for its intended purpose. A minor defect is one that does not materially reduce the usability of the unit for its intended purpose or is an infringement from established standards and has no significant bearing on its effective use or operation.

### 8.4 APPEARANCE

An appearance test should be conducted by human sight at approximately 30 cm distance from the LCD module under florescent light. The inspection area of LCD panel shall be within the range of following limits.

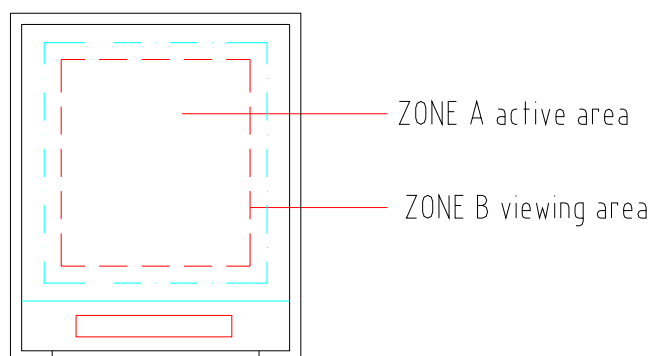

## 8.5 INCOMING INSPECTION STANDARD FOR TFT-LCD PANEL

DEFECT TYPE			LIMIT			Note			
VISUAL DEFECT	INTERNAL	SPOT	$\phi < 0.15\text{mm}$		Ignore	Note1			
			$0.15\text{mm} \leq \phi \leq 0.5\text{mm}$		$N \leq 4$				
			$0.5\text{mm} < \phi$		$N = 0$				
		FIBER	$0.03\text{mm} < W \leq 0.1\text{mm},$ $L \leq 5\text{mm}$		$N \leq 3$		Note1		
			$1.0\text{mm} < W, 1.5\text{mm} < L$		$N = 0$				
		POLARIZER BUBBLE	$\phi < 0.15\text{mm}$		Ignore		Note1		
			$0.15\text{mm} \leq \phi \leq 0.5\text{mm}$		$N \leq 2$				
			$0.5\text{mm} < \phi$		$N = 0$				
		Mura		It' OK if mura is slight visible through 6%ND filter					
		ELECTRICAL DEFECT	BRIGHT DOT		A Grade			B Grade	
C Area	O Area				Total	C Area	O Area	Total	Note3
$N \leq 0$	$N \leq 2$				$N \leq 2$	$N \leq 2$	$N \leq 3$	$N \leq 5$	Note2
DARK DOT			$N \leq 2$	$N \leq 3$	$N \leq 3$	$N \leq 3$	$N \leq 5$	$N \leq 8$	
TOTAL DOT			$N \leq 4$			$N \leq 5$	$N \leq 6$	$N \leq 8$	Note2
TWO ADJACENT DOT			$N \leq 0$	$N \leq 1$ pair	$N \leq 1$ pair	$N \leq 1$ pair	$N \leq 1$ pair	$N \leq 1$ pair	Note4
THREE OR MORE ADJACENT DOT			NOT ALLOWED						
LINE DEFECT		NOT ALLOWED							

- (1) One pixel consists of 3 sub-pixels, including R,G, and B dot.(Sub-pixel = Dot)  
 (2) LITTLE BRIGHT DOT acceptable under 6% ND-Filter

[Note1] W : Width[mm], L : Length[mm], N : Number,  $\phi$ : Average Diameter

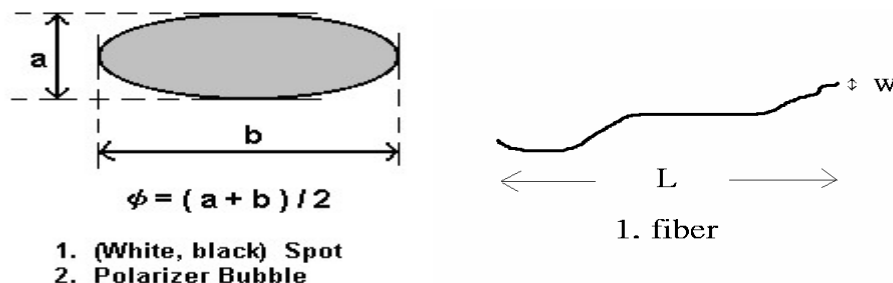

[Note2] Bright dot is defined through 5% transmission ND Filter as following.

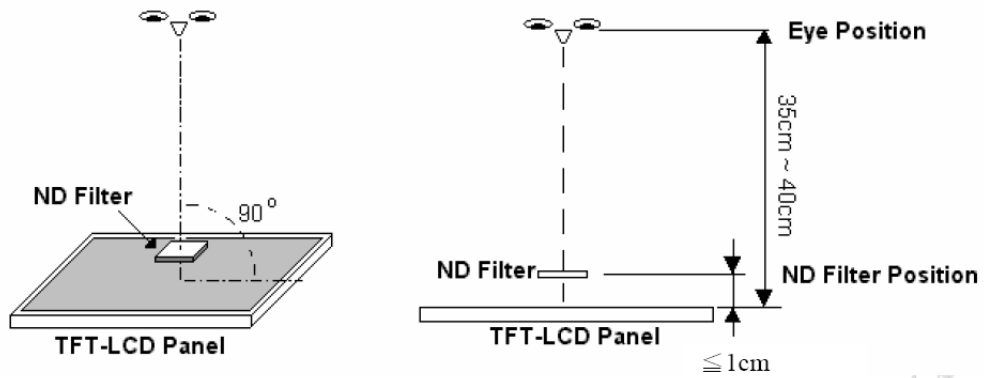

**[Note3]**

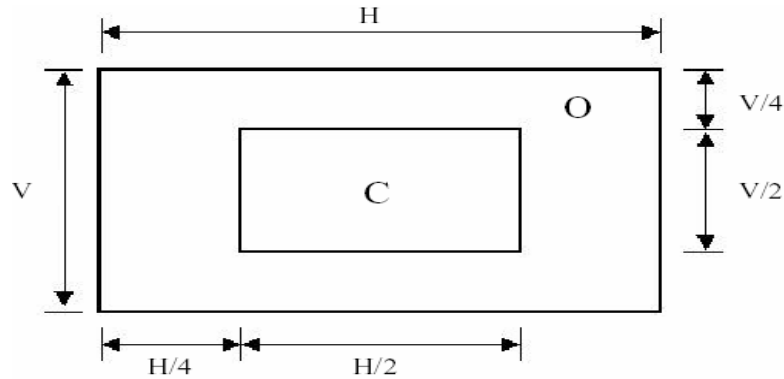

**C Area: Center of display area**

**O Area: Outer of display area**

**[Note4]**

Judge defect dot and adjacent dot as following. Allow below (as A, B, C and D status) adjacent defect dots, including bright and dark adjacent dot. And they will be counted 2 defect dots in total quantity.

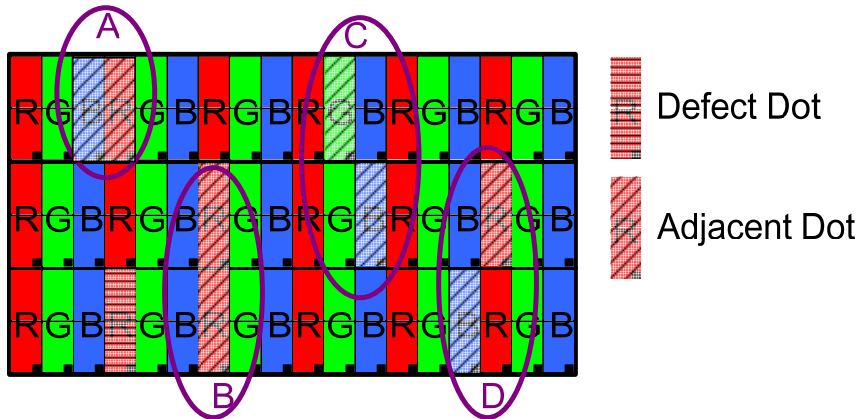

(1) The defects that are not defined above and considered to be problem shall be reviewed and discussed by both parties.

(2) Defects on the Black Matrix, out of Display area, are not considered as a defect or counted.

## 8.6 RELIABILITY TEST CONDITIONS

ITEM	CONDITIONS	NOTE
HIGH TEMPERATURE OPERATION	60°C , 240Hrs	
HIGH TEMPERATURE AND HIGH HUMIDITY OPERATION	40°C , 90%RH , 240Hrs	
HIGH TEMPERATURE AND HIGH HUMIDITY STORAGE	60°C , 90%RH , 48 Hrs	
HIGH TEMPERATURE STORAGE	70°C , 240Hrs	
LOW TEMPERATURE OPERATION	-10°C , 240Hrs	
LOW TEMPERATURE STORAGE	-20°C , 240Hrs	
THERMAL SHOCK (No operation)	-20°C (0.5Hr) ~60°C (0.5Hr) 200Cycle	
ESD	±8kV&±15kV air & contact test	(1)
	0Ω,±200V contact test	(2)

NOTE : Measure point :

(1) LCD glass and bezel

(2) IF connector pins

## **10. USE PRECAUTIONS**

### **10-1 Handling precautions**

- (1) The polarizing plate may break easily so be careful when handling it. Do not touch, press or rub it with a hard-material tool like tweezers.
- (2) Do not touch the polarizing plate surface with bare hands so as not to make it dirty. If the surface or other related part of the polarizing plate is dirty, soak a soft cotton cloth or chamois leather in benzene and wipe off with it. Do not use chemical liquids such as acetone, toluene and isopropyl alcohol. Failure to do so may bring chemical reaction phenomena and deteriorations.
- (3) Remove any spit or water immediately. If it is left for hours, the suffered part may deform or decolorize.
- (4) If the LCD element breaks and any LC stuff leaks, do not suck or lick it. Also if LC stuff is stuck on your skin or clothing, wash thoroughly with soap and water immediately.

### **10-2 Installing precautions**

- (1) The PCB has many ICs that may be damaged easily by static electricity. To prevent breaking by static electricity from the human body and clothing, earth the human body properly using the high resistance and discharge static electricity during the operation. In this case, however, the resistance value should be approx. 1MΩ and the resistance should be placed near the human body rather than the ground surface. When the indoor space is dry, static electricity may occur easily so be careful. We recommend the indoor space should be kept with humidity of 60% or more. When a soldering iron or other similar tool is used for assembly, be sure to earth it.
- (2) When installing the module and ICs, do not bend or twist them. Failure to do so may crack LC element and cause circuit failure.
- (3) To protect LC element, especially polarizing plate, use a transparent protective plate (e.g., acrylic plate, glass etc) for the product case.
- (4) Do not use an adhesive like a both-side adhesive tape to make LCD surface (polarizing plate) and product case stick together. Failure to do so may cause the polarizing plate to peel off

### **10-3 Storage precautions**

- (1) Avoid a high temperature and humidity area. Keep the temperature between 0°C and 35°C and also the humidity under 60%.
- (2) Choose the dark spaces where the product is not exposed to direct sunlight or fluorescent light.
- (3) Store the products as they are put in the boxes provided from us or in the same conditions as we recommend.

#### **10-4 Operating precautions**

- (1) Do not boost the applied drive voltage abnormally. Failure to do so may break ICs. When applying power voltage, check the electrical features beforehand and be careful. Always turn off the power to the LC module controller before removing or inserting the LC module input connector. If the input connector is removed or inserted while the power is turned on, the LC module internal circuit may break.
- (2) The display response may be late if the operating temperature is under the normal standard, and the display may be out of order if it is above the normal standard. But this is not a failure; this will be restored if it is within the normal standard.
- (3) The LCD contrast varies depending on the visual angle, ambient temperature, power voltage etc. Obtain the optimum contrast by adjusting the LC drive voltage.
- (4) When carrying out the test, do not take the module out of the low-temperature space suddenly. Failure to do so will cause the module condensing, leading to malfunctions.
- (5) Make certain that each signal noise level is within the standard (L level: 0.2Vdd or less and H level: 0.8Vdd or more) even if the module has functioned properly. If it is beyond the standard, the module may often malfunction. In addition, always connect the module when making noise level measurements.
- (6) The CMOS ICs are incorporated in the module and the pull-up and pull-down function is not adopted for the input so avoid putting the input signal open while the power is ON.
- (7) The characteristic of the semiconductor element changes when it is exposed to light emissions, therefore ICs on the LCD may malfunction if they receive light emissions. To prevent these malfunctions, design and assemble ICs so that they are shielded from light emissions.
- (8) Crosstalk occurs because of characteristics of the LCD. In general, crosstalk occurs when the regularized display is maintained. Also, crosstalk is affected by the LC drive voltage. Design the contents of the display, considering crosstalk.

#### **10-5 Other**

- (1) Do not disassemble or take the LC module into pieces. The LC modules once disassembled or taken into pieces are not the guarantee articles.
- (2) The residual image may exist if the same display pattern is shown for hours. This residual image, however, disappears when another display pattern is shown or the drive is interrupted and left for a while. But this is not a problem on reliability.
- (3) AMIPRE will provide one year warranty for all products and three months warranty for all repairing products..

# 11. OUTLINE DIMENSION

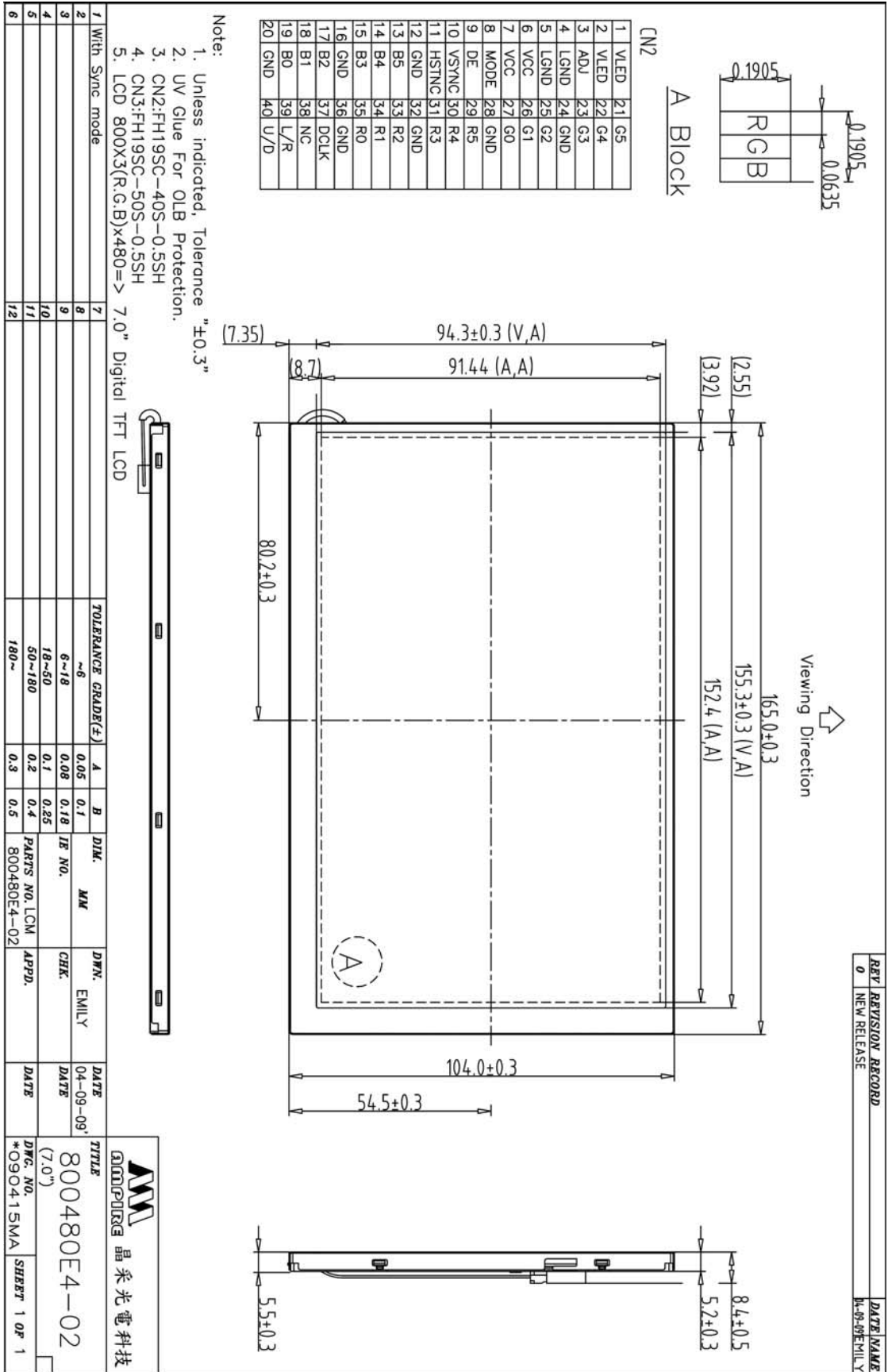

REV	REVISION RECORD	DATE NAME
0	NEW RELEASE	M-09-09EMILY

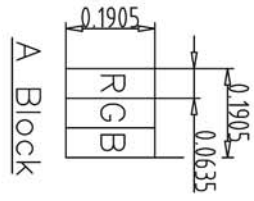

CN2	
1	VLED
2	VLED
3	ADJ
4	LGND
5	LGND
6	VCC
7	VCC
8	MODE
9	DE
10	VSYNC
11	HSTNC
12	GND
13	B5
14	B4
15	B3
16	GND
17	B2
18	B1
19	B0
20	GND
21	G5
22	G4
23	G3
24	GND
25	G2
26	G1
27	G0
28	GND
29	R5
30	R4
31	R3
32	GND
33	R2
34	R1
35	R0
36	GND
37	DCLK
38	NC
39	L/R
40	U/D

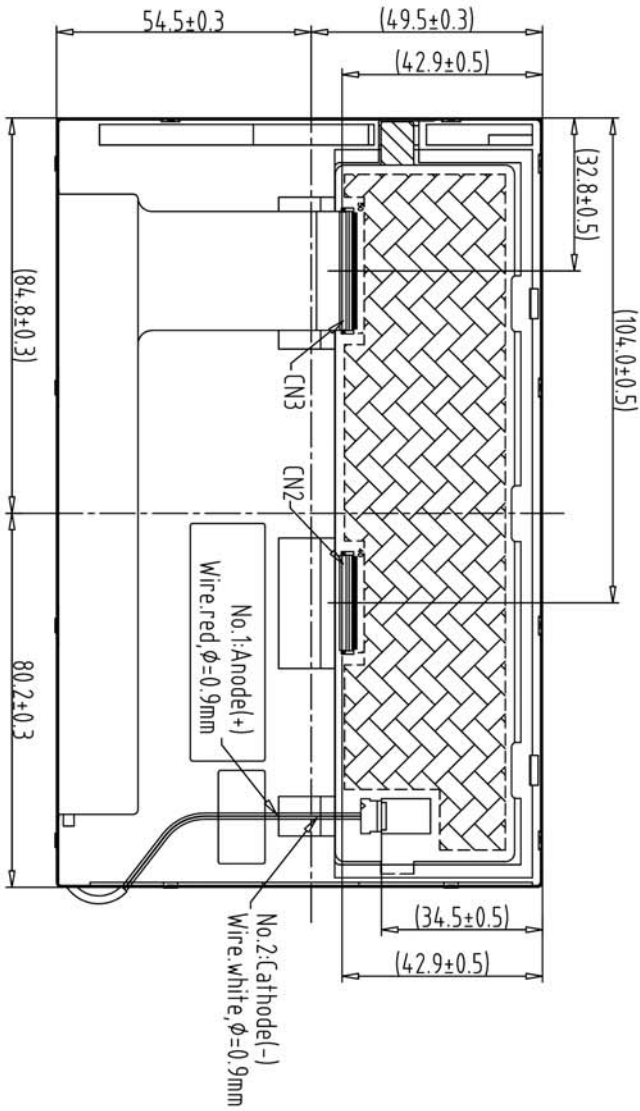

Back View

- Note:
1. Unless indicated, Tolerance "±0.3"
  2. UV Glue For OLB Protection.
  3. CN2:FH19SC-40S-0.5SH
  4. CN3:FH19SC-50S-0.5SH
  5. LCD 800X3(R,G,B)×480=> 7.0" Digital TFT LCD

1	With Sync mode	7	TOLERANCE GRAD(±)	A	B	DIK.	MM	DWN.	EMILY	DATE	TITLE
2		8	~6	0.05	0.1					04-09-09	800480E4-02
3		9	6~18	0.08	0.18	IE NO.		CHK.		DATE	(7.0")
4		10	18~50	0.1	0.25						
5		11	50~180	0.2	0.4	PARTS NO.LCM-1	800480E4-02	APPD.		DATE	DWG. NO.
6		12	180~	0.3	0.5	800480E4-02					*090416MA
											SHEET 1 OF 1

**MM** 晶采光電科技  
**MINIPURE**