



A Brighter Solution

# AMP DISPLAY INC.

## SPECIFICATIONS

### 7.0-IN COLOR TFT MODULE W/ TOUCH -lvs

CUSTOMER:	
CUSTOMER PART NO.	
AMP DISPLAY PART NO.	AM-800480STMQW-TA1
APPROVED BY:	
DATE:	

APPROVED FOR SPECIFICATIONS

APPROVED FOR SPECIFICATION AND PROTOTYPES

## AMP DISPLAY INC

9856 SIXTH STREET RANCHO CUCAMONGA CA 91730  
TEL: 909-980-13410 FAX: 909-980-1419  
WWW.AMPDISPLAY.COM

## RECORD OF REVISION

Revision Date	Page	Contents	Editor
2010/1/22	--	New Release	Edward

## 1. Features

7 inch module is a color active matrix thin film transistor (TFT) liquid crystal display (LCD) that uses amorphous silicon TFT as a switching device. This model is composed of a TFT LCD panel, a driving circuit and a back light system. This TFT LCD has a 7.0 (16:9) inch diagonally measured active display area with WVGA (800 horizontal by 480 vertical pixel) resolution.

- (1) Construction: 7" a-Si TFT active matrix, White LED Backlight and Touch Panel.
- (2) Resolution (pixel): 800(R.G.B) X 480
- (3) Number of the Colors : 262K colors ( R , G , B 6 bit digital each)
- (4) LCD type : Transmissive , normally White
- (5) Viewing Direction: 6 O'clock ( The direction it's hard to be discolored )
- (6) Interface : LVDS interface

## 2. PHYSICAL SPECIFICATIONS

Item	Specifications	unit
LCD size	7 inch (Diagonal)	
Outline Dimension (Include connector)	165.0 x 104.44 x 9.52 (typ.)	mm
Number of Pixel	800 RGB (H) x 480 (V)	pixels
Pixel pitch	0.1905 (H) x 0.1905 (V)	mm
Pixel arrangement	RGB Vertical stripe	
Display mode	Normally white	
Surface treatment	Antiglare, Hard-Coating (3H) with EWV film	
Weight	T.B.D (typ.)	g
Back-light	Single LED (Side-Light type)	
Power consumption (B/L system)	T.B.D (max.)	W

### 3. ABSOLUTE MAX. RATINGS

#### 3-1 Electrical Absolute Rating

##### 3-1-1 TFT LCD Module

Item	Symbol	Values		UNIT	Note
		Min.	Max.		
Power voltage	VCC	-0.5	4.0	V	GND=0V
Voltage range at any terminal		-0.5	VCC+0.3	V	

#### 3-2 Environment Absolute Rating

Item	Symbol	Min.	Max.	Unit	Note
Operating Temperature	Topa	-20	70	°C	
Storage Temperature	Tstg	-30	80	°C	

### 4. ELECTRICAL CHARACTERISTICS

#### 4-1 TFT LCD Module

		MIN	NOM	MAX	UNIT
$V_{CC}$	Supply voltage	3	3.3	3.6	V
$V_{IH}$	High-level input voltage ( $\overline{SHTDN}$ )	2			V
$V_{IL}$	Low-level input voltage ( $\overline{SHTDN}$ )			0.8	V
$ V_{ID} $	Magnitude differential input voltage	0.1		0.6	V
$V_{IC}$	Common-mode input voltage	$\frac{ V_{ID} }{2}$		$2.4 - \frac{ V_{ID} }{2}$	V

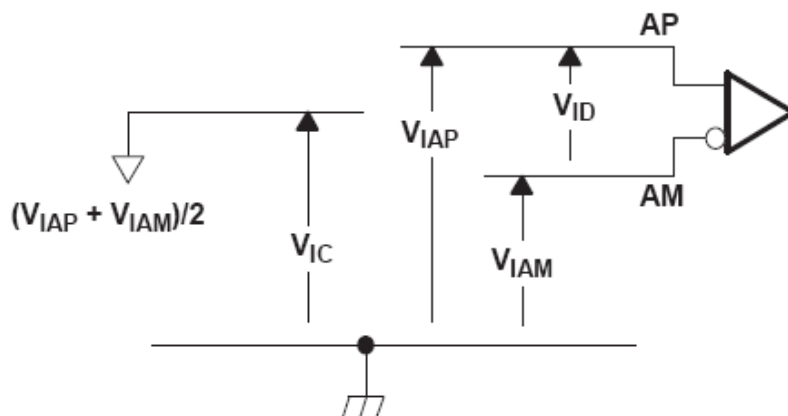

## 4-2 Backlight Unit

Item	Symbol	Min.	Typ.	Max.	Unit	Note
LED Driver Voltage	VLED	-	5	-	V	
Power Supply Current For LED Driver	ILED	-	T.B.D	-	mA	VLED=5V VADJ=3.3V (duty 100%)
ADJ Input Voltage	V <sub>ADJ</sub>	-	3.3	-	V	duty=100% Note(3)
LED voltage	VAK	--	9.9	--	V	I <sub>LED</sub> =160mA Ta=25°C
LED current	ILED	--	160	--	mA	Ta=25°C
		--	145	--	mA	Ta=60°C
LED Life Time	-	10K	20K	--	Hour	Note (2)

Note (1) The constant current source is needed for white LED back-light driving.

When LCM is operated over 60 deg.C ambient temperature, the I<sub>LED</sub> of the LED back-light should be adjusted to 135mA max

Note (2) Brightness to be decreased to 50% of the initial value.

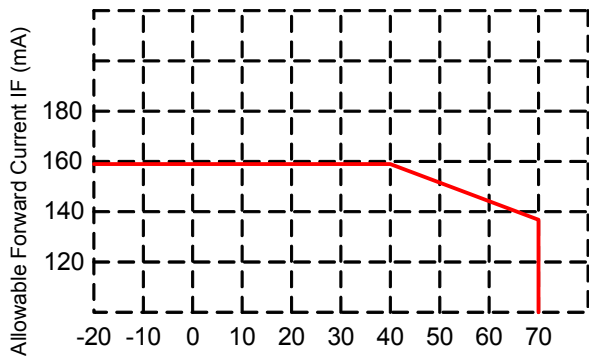
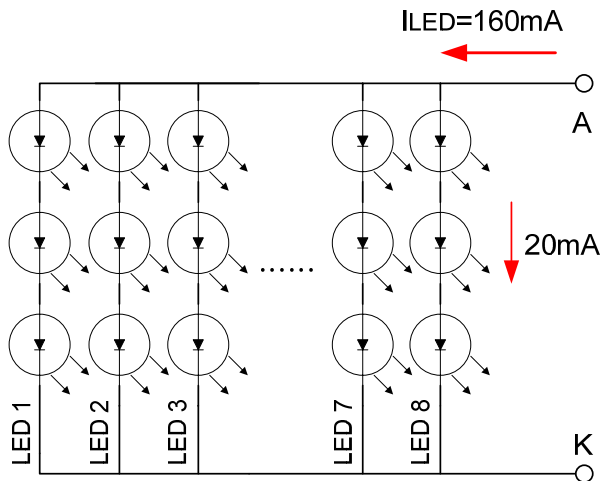

LED Light Bar Circuit

Note(3) VLEDADJ is PWM signal input. It is for brightness control.

Item	Symbol	Min	Typ	Max	Unit
ADJ signal frequency	$f_{PWM}$	100	--	1K	Hz
ADJ signal logic level High	$V_{IH}$	2V	--	VLED (5.0V)	V
ADJ signal logic level Low	$V_{IL}$	0	--	0.5	V

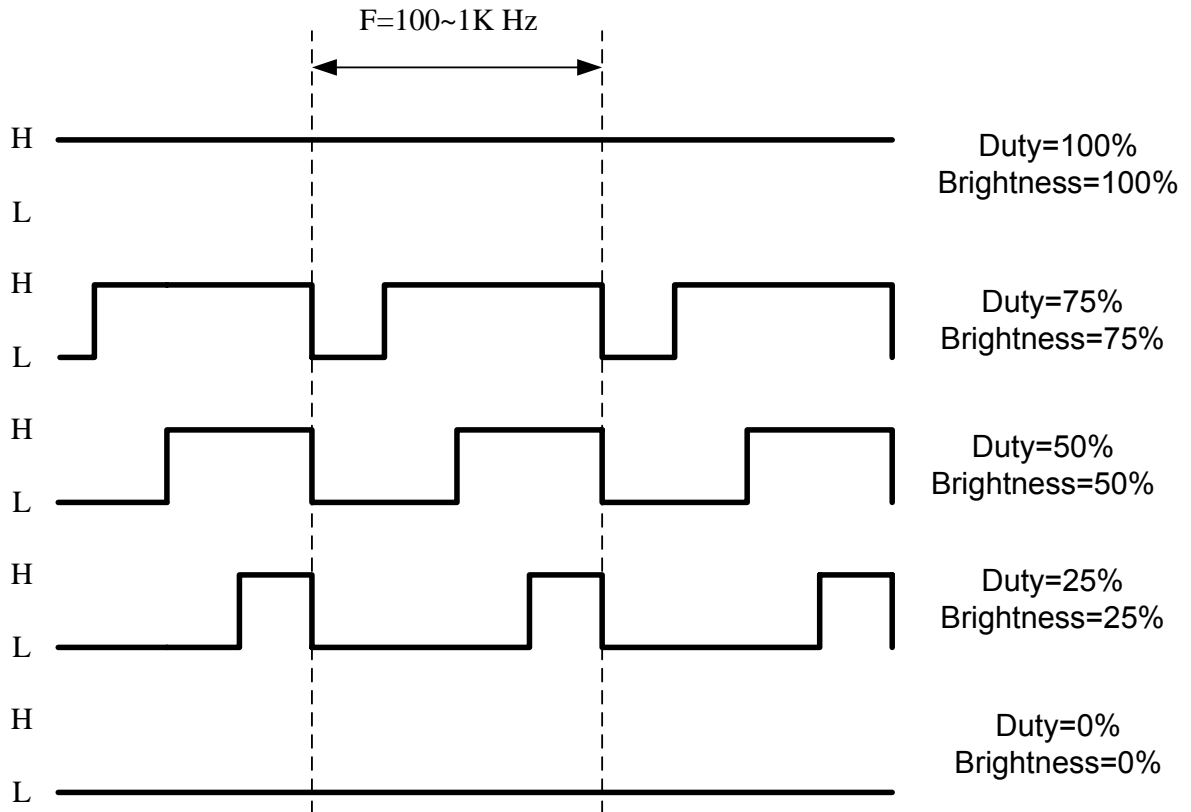

### 4-3 Touch Panel Electrical Specification

Parameter	Condition	Standard Value
Terminal Resistance	X Axis	200 ~ 900 $\Omega$
	Y Axis	200 ~ 900 $\Omega$
Insulating Resistance	DC 25 V	More than 20M $\Omega$
Linearity	--	$\pm 1.5$ %
Notes life by Pen	Note A	100,000 times(min)
Input life by finger	Note B	1,000,000 times (min)

#### Note A .

Notes area for pen notes life test is 10 x 9 mm.

Size of word is 7.5 x 6.72

Shape of pen end : R0.8

Load : 250 g

#### Note B

By Silicon rubber tapping at same point

Shape of rubber end : R8

Load : 200g

Frequency : 5 Hz

	Symbol	Function
1	Y2	Touch Panel Top Signal in X Axis
2	X2	Touch Panel Left Signal in Y Axis
3	Y1	Touch Panel Bottom Signal in X Axis
4	X1	Touch Panel Right Signal in Y Axis

## 5. Optical Specifications

### 5-1 Optical specification

Item		Symbol	Condition	Min.	Typ.	Max.	Unit	Note
Viewing Angle	Front	$\theta f$	$CR \geq 10$	50	60	--	deg.	(1)(2)(3)
	Back	$\theta b$		60	70	--		
	Left	$\theta l$		60	70	--		
	Right	$\theta r$		60	70	--		
Contrast ratio		CR	$\Theta = \Phi = 0^\circ$	250	400	--	--	(1)(3)
Response Time		$T_r$	$\Theta = \Phi = 0^\circ$	--	5	10	ms	(1)(4)
		$T_f$		--	11	16	ms	(1)(4)
Color chromaticity	White	$W_x$	$\Theta = \Phi = 0^\circ$	0.249	0.299	0.349	--	(1)
		$W_y$		0.278	0.328	0.378		
	Red	$R_x$		T.B.D.	T.B.D.	T.B.D.		
		$R_y$		T.B.D.	T.B.D.	T.B.D.		
	Green	$G_x$		T.B.D.	T.B.D.	T.B.D.		
		$G_y$		T.B.D.	T.B.D.	T.B.D.		
	Blue	$B_x$		T.B.D.	T.B.D.	T.B.D.		
		$B_y$		T.B.D.	T.B.D.	T.B.D.		
Luminance		L	$\Theta = \Phi = 0^\circ$	240	280	--	cd/m <sup>2</sup>	(1)(5)
Luminance Uniformity		$\Delta L$	$\Theta = \Phi = 0^\circ$	70	--	--	%	(1)(5)(6)

Note 1:  $T_a = 25^\circ\text{C}$ . To be measured on the center area of panel after 10 minutes operation.

Note 2: Definition of Viewing Angle

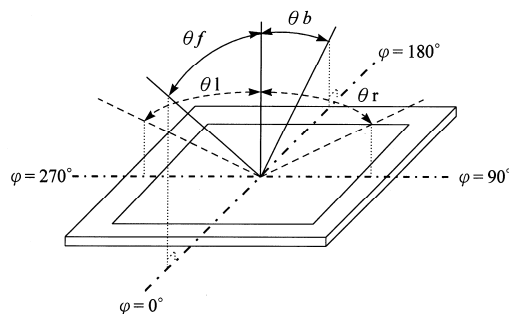

Note 3: Definition of contrast ratio:

Contrast ratio is calculated with the following formula.

$$\text{Contrast ratio(CR)} = \frac{\text{Photo detector output when LCD is at "White" state}}{\text{Photo detector Output when LCD is at "Black" state}}$$

Note 4: Definition of response time:

The output signals of photo detector are measured when the input signals are changed from "black" to "white" (falling time) and from "white" to "black" (rising time) respectively. The response time is defined as the time interval between the 10% and 90% of amplitudes. Refer to figure as below.

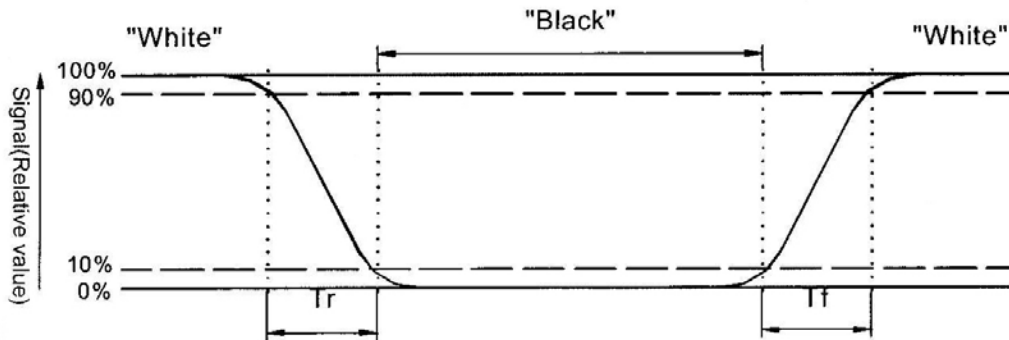

Note 5 : Luminance is measured at point 5 of the display.

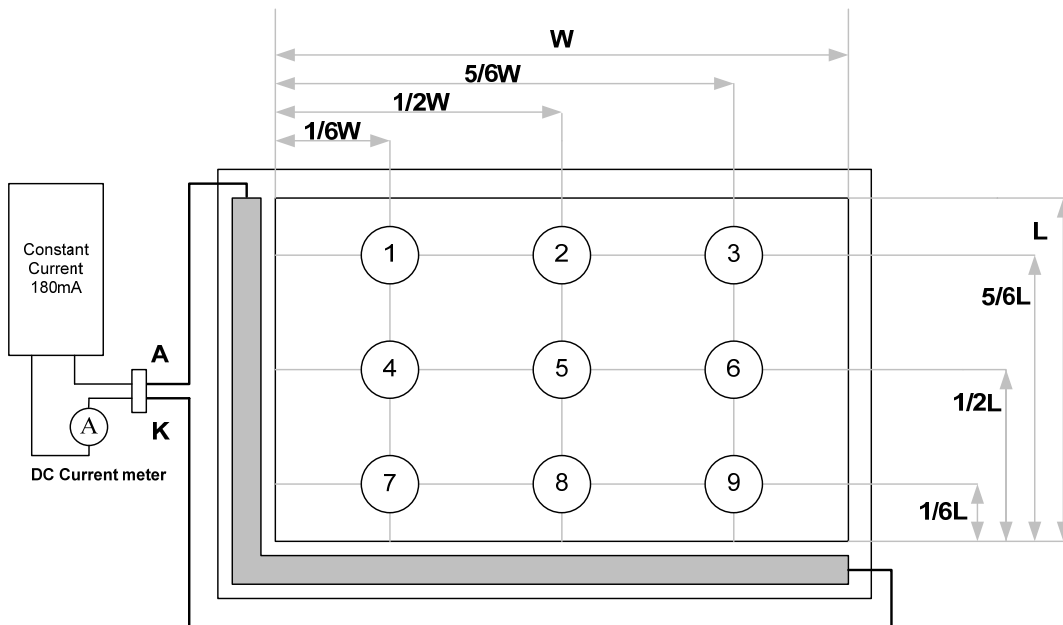

Note 6 : Definition of Luminance Uniformity

$$\Delta L = [ L(\text{min.}) \text{ of 9 points} / L(\text{max.}) \text{ of 9 points} ] \times 100\%$$

### 6. Block Diagram

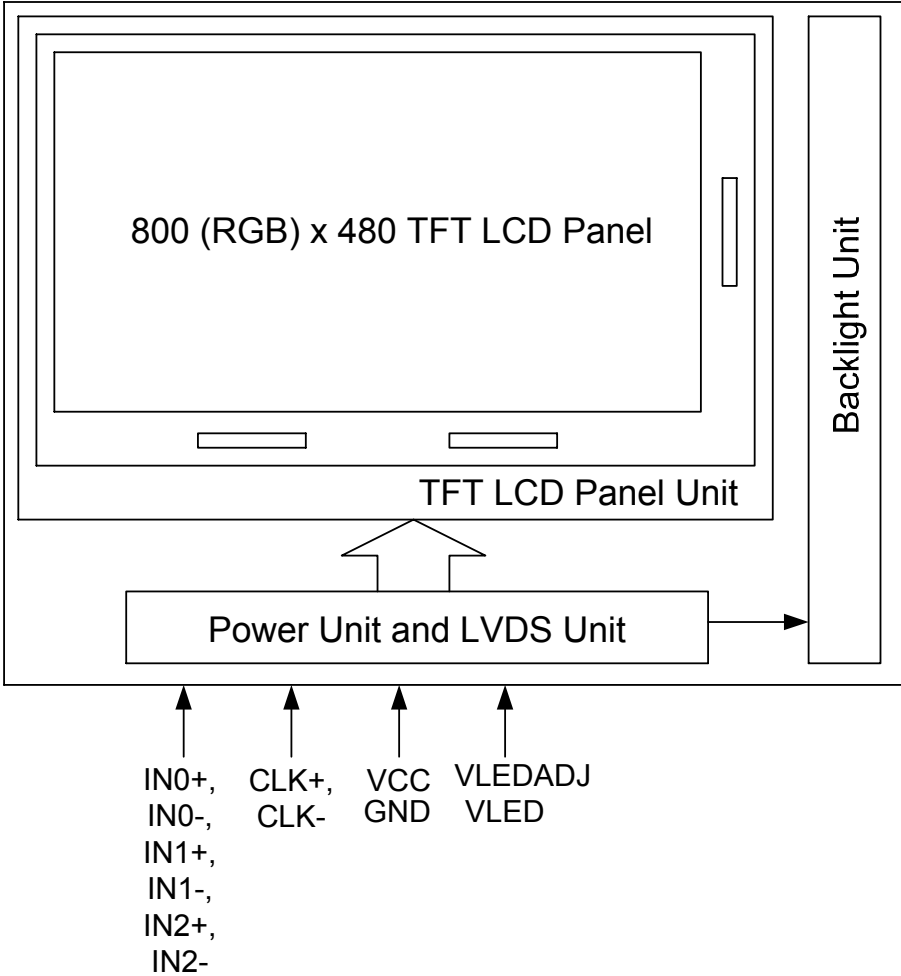

## 7. INTERFACE

Pin No.	Symbol	Function
1	VDD	POWER SUPPLY:3.3V
2	VDD	POWER SUPPLY:3.3V
3	Gnd	Power Ground
4	Gnd	Power Ground
5	IN0-	Transmission Data of Pixels
6	IN0+	Transmission Data of Pixels
7	Gnd	Power Ground
8	IN1-	Transmission Data of Pixels 1
9	IN1+	Transmission Data of Pixels 1
10	Gnd	Power Ground
11	IN2-	Transmission Data of Pixels 2
12	IN2+	Transmission Data of Pixels 2
13	Gnd	Power Ground
14	CLK-	Sampling Clock
15	CLK+	Sampling Clock
16	Gnd	Power Ground
17	LEDADJ	LED PWM SIGNAL
18	VLED	POWER SUPPLY for Backlight : 5V
19	Gnd	Power Ground
20	Gnd	Power Ground

## 8. INPUT SIGNAL :

### 8-1 LVDS Signal

switching characteristics over recommended operating conditions (unless otherwise noted)

PARAMETER	TEST CONDITIONS	MIN	TYP†	MAX	UNIT	
$t_{su}$	Setup time, D0–D20 to CLKOUT↓	5			ns	
$t_h$	Data hold time, CLKOUT↓ to D0–D20	5			ns	
$t_{(RSKM)}$	Receiver input skew margin§ (see Figure 7)		700	550	ps	
$t_d$	Delay time, CLKIN↑ to CLKOUT↓ (see Figure 7)		5	3	7	ns
$t_{en}$	Enable time, $\overline{SHTDN}$ to phase lock		1		ms	
$t_{dis}$	Disable time, $\overline{SHTDN}$ to off state		400		ns	
$t_t$	Transition time, output (10% to 90% $t_r$ or $t_f$ ) (data only)		3		ns	
$t_t$	Transition time, output (10% to 90% $t_r$ or $t_f$ ) (clock only)		1.5		ns	
$t_w$	Pulse duration, output clock		$0.50 t_c$		ns	

† All typical values are at  $V_{CC} = 3.3\text{ V}$ ,  $T_A = 25^\circ\text{C}$ .

§ The parameter  $t_{(RSKM)}$  is the timing margin available to allocate to the transmitter and interconnection skews and clock jitter. The value of this parameter at clock periods other than 15.38 ns can be calculated from  $t_{(RSKM)} = t_c/14 - 550\text{ ps}$ .

¶  $|Input\ clock\ jitter|$  is the magnitude of the change in input clock period.

#### PARAMETER MEASUREMENT INFORMATION

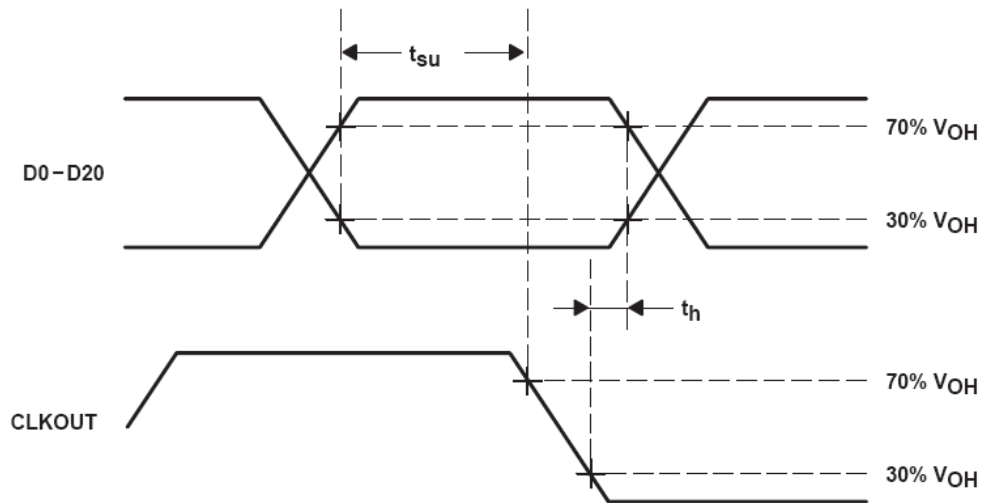

Figure 5. Setup and Hold Time Waveforms

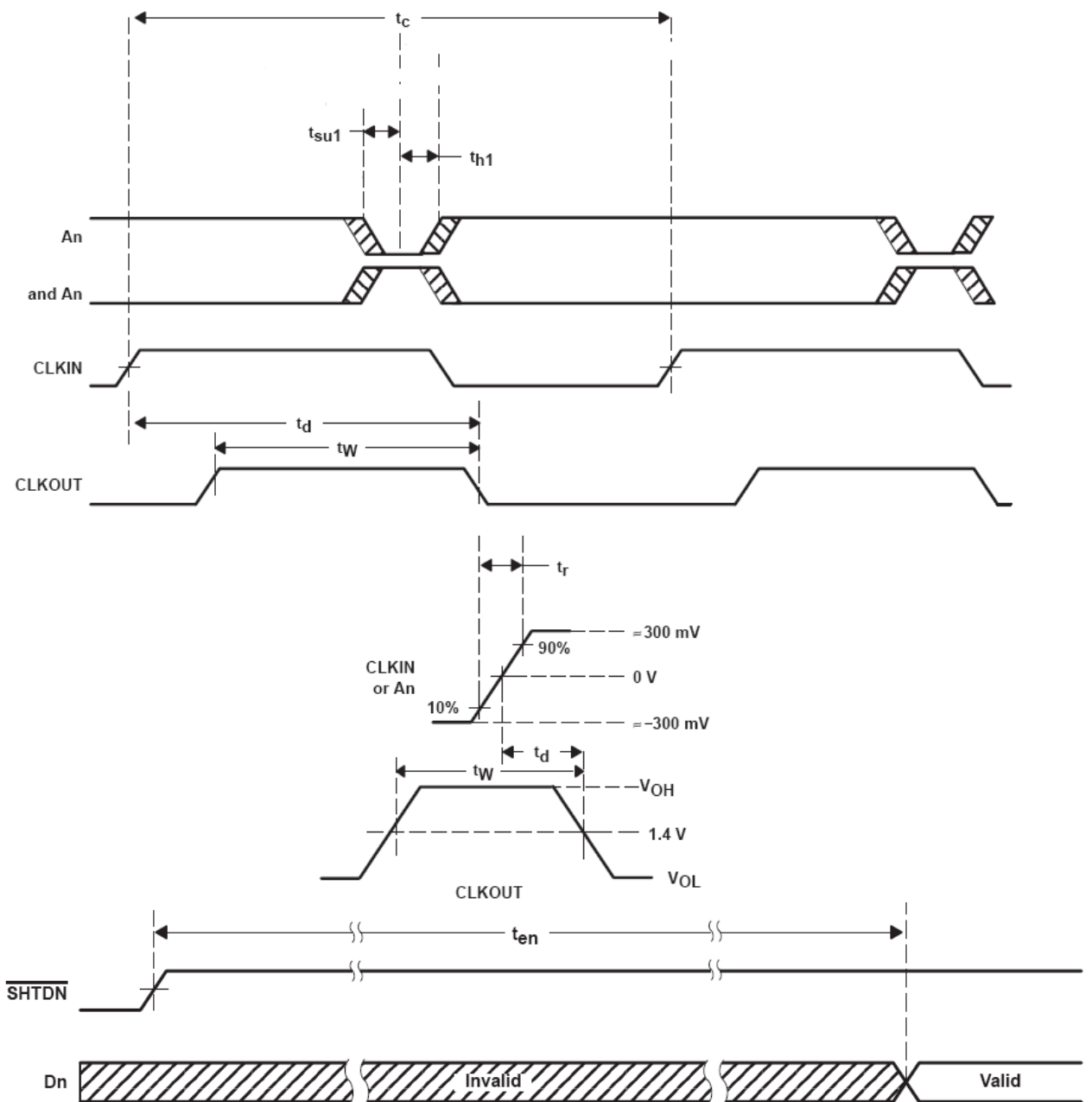

Figure 7. Enable Time Waveforms

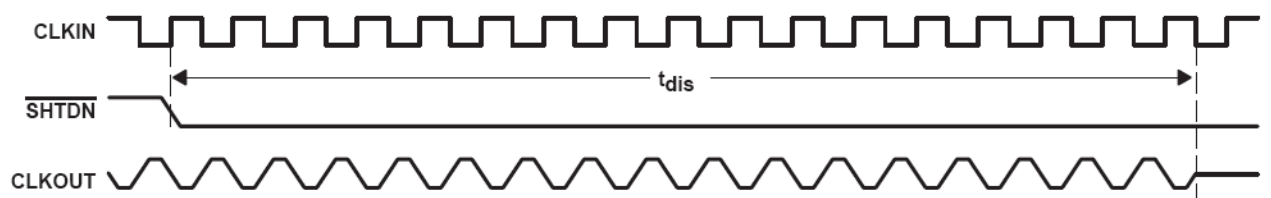

Figure 8. Disable Time Waveforms

## 8-2 Input Signal (DE only mode)

Frame rate range : 60Hz~65Hz

Parameter	Symbol	Rating			Unit
		Min.	Typ.	Max.	
Data setup time	Tdsu	6	-	-	ns
Data hold time	Tdhd	6	-	-	ns
DE setup time	Tesu	6	-	-	ns
CLK frequency	F <sub>CPH</sub>	29.40	33.26	42.48	MHz
CLK period	T <sub>CPH</sub>	23.54	30.06	34.01	ns
CLK pulse duty	T <sub>CWH</sub>	40	50	60	%
CLK pulse duty	T <sub>CWL</sub>	40	50	60	%
DE period	T <sub>DEH</sub> +T <sub>DEL</sub>	1000	1056	1200	T <sub>CPH</sub>
DE pulse width	T <sub>DEH</sub>	-	800	-	T <sub>CPH</sub>
DE frame blanking	T <sub>DEB</sub>	10	45	110	T <sub>DEH</sub> +T <sub>DEL</sub>
DE frame width	T <sub>DE</sub>	-	480	-	T <sub>DEH</sub> +T <sub>DEL</sub>

Note : We suggest using the typical value, so it can have better performance.

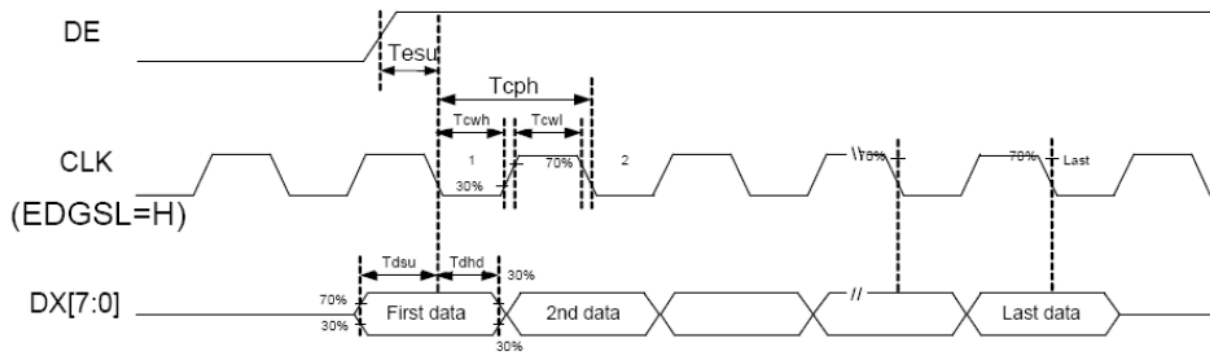

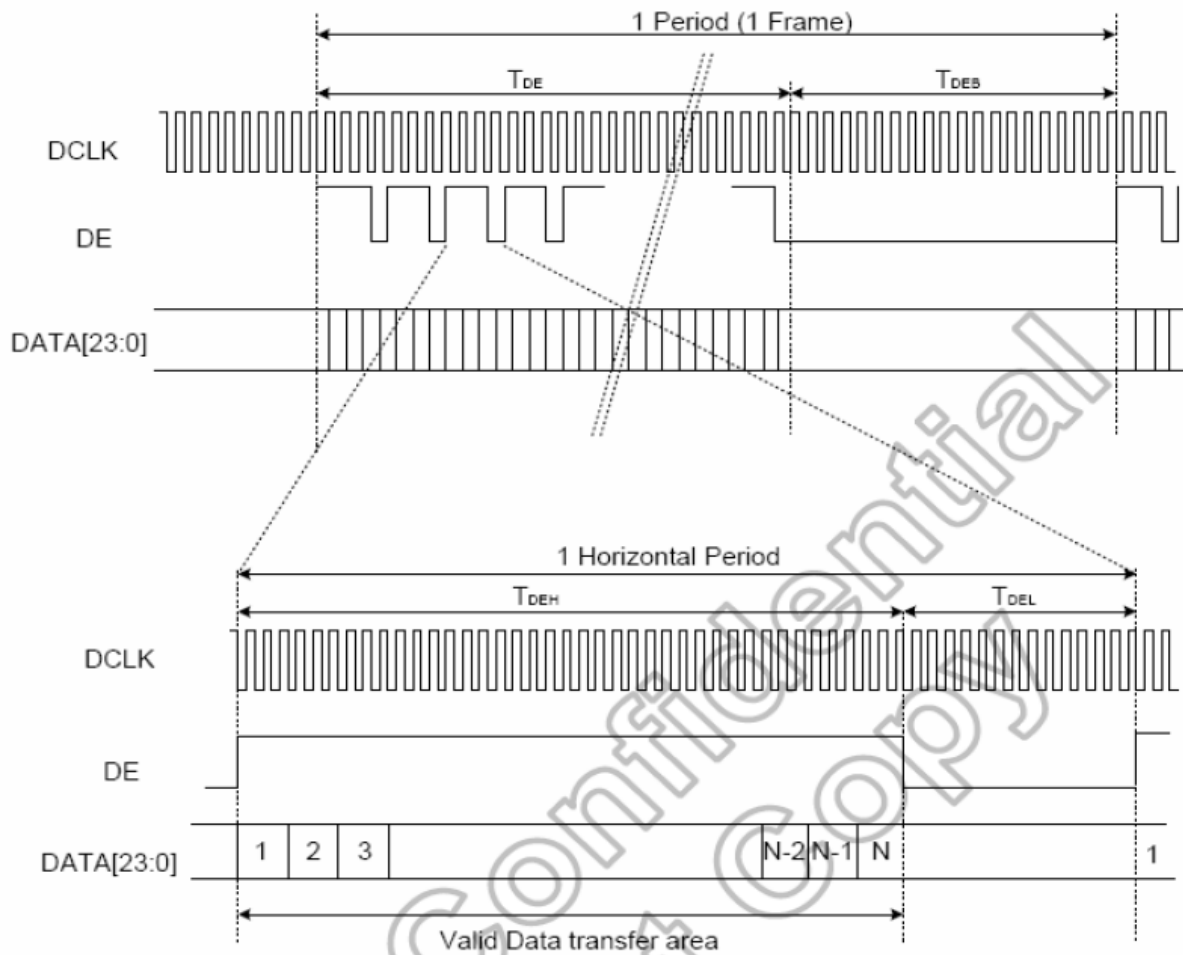

## 9. DISPLAYED COLOR AND INPUT DATA

	Color & Gray Scale	DATA SIGNAL																	
		R5	R4	R3	R2	R1	R0	G5	G4	G3	G2	G1	G0	B5	B4	B3	B2	B1	B0
Basic Color	Black	0	0	0	0	0	0	0	0	0	0	0	0	0	0	0	0	0	0
	Red(63)	1	1	1	1	1	1	0	0	0	0	0	0	0	0	0	0	0	0
	Green(63)	0	0	0	0	0	0	1	1	1	1	1	1	0	0	0	0	0	0
	Blue(63)	0	0	0	0	0	0	0	0	0	0	0	0	1	1	1	1	1	1
	Cyan	0	0	0	0	0	0	1	1	1	1	1	1	1	1	1	1	1	1
	Magenta	1	1	1	1	1	1	0	0	0	0	0	0	1	1	1	1	1	1
	Yellow	1	1	1	1	1	1	1	1	1	1	1	1	0	0	0	0	0	0
	White	1	1	1	1	1	1	1	1	1	1	1	1	1	1	1	1	1	1
Red	Black	0	0	0	0	0	0	0	0	0	0	0	0	0	0	0	0	0	0
	Red(1)	0	0	0	0	0	1	0	0	0	0	0	0	0	0	0	0	0	0
	Red(2)	0	0	0	0	1	0	0	0	0	0	0	0	0	0	0	0	0	0
	:	:	:	:	:	:	:	:	:	:	:	:	:	:	:	:	:	:	:
	Red(31)	0	1	1	1	1	1	0	0	0	0	0	0	0	0	0	0	0	0
	:	:	:	:	:	:	:	:	:	:	:	:	:	:	:	:	:	:	:
	Red(62)	1	1	1	1	1	0	0	0	0	0	0	0	0	0	0	0	0	0
	Red(63)	1	1	1	1	1	1	0	0	0	0	0	0	0	0	0	0	0	0
Green	Black	0	0	0	0	0	0	0	0	0	0	0	0	0	0	0	0	0	0
	Green(1)	0	0	0	0	0	0	0	0	0	0	0	1	0	0	0	0	0	0
	Green(2)	0	0	0	0	0	0	0	0	0	0	1	0	0	0	0	0	0	0
	:	:	:	:	:	:	:	:	:	:	:	:	:	:	:	:	:	:	:
	Green(31)	0	0	0	0	0	0	0	1	1	1	1	0	0	0	0	0	0	0
	:	:	:	:	:	:	:	:	:	:	:	:	:	:	:	:	:	:	:
	Green(62)	0	0	0	0	0	0	1	1	1	1	1	0	0	0	0	0	0	0
	Green(63)	0	0	0	0	0	0	1	1	1	1	1	1	0	0	0	0	0	0
Blue	Black	0	0	0	0	0	0	0	0	0	0	0	0	0	0	0	0	0	0
	Blue(1)	0	0	0	0	0	0	0	0	0	0	0	0	0	0	0	0	0	1
	Blue(2)	0	0	0	0	0	0	0	0	0	0	0	0	0	0	0	0	1	0
	:	:	:	:	:	:	:	:	:	:	:	:	:	:	:	:	:	:	:
	Blue(31)	0	0	0	0	0	0	0	0	0	0	0	0	0	1	1	1	1	1
	:	:	:	:	:	:	:	:	:	:	:	:	:	:	:	:	:	:	:
	Blue(62)	0	0	0	0	0	0	0	0	0	0	0	0	1	1	1	1	1	0
	Blue(63)	0	0	0	0	0	0	0	0	0	0	0	0	1	1	1	1	1	1

## 10. RELIABILITY TEST CONDITIONS

### 10.1. Test Conditions

Tests should be conducted under the following conditions :

Ambient temperature :  $25 \pm 5^{\circ}\text{C}$

Humidity :  $60 \pm 25\% \text{ RH}$ .

### 10.2. Sampling Plan

Sampling method shall be in accordance with MIL-STD-105E , level II, normal single sampling plan .

### 10.3. Acceptable Quality Level

A major defect is defined as one that could cause failure to or materially reduce the usability of the unit for its intended purpose. A minor defect is one that does not materially reduce the usability of the unit for its intended purpose or is an infringement from established standards and has no significant bearing on its effective use or operation.

### 10.4. Appearance

An appearance test should be conducted by human sight at approximately 30 cm distance from the LCD module under florescent light. The inspection area of LCD panel shall be within the range of following limits.

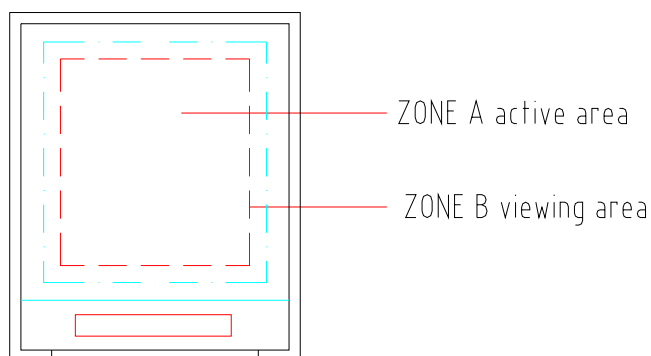

### 10.5. Incoming Inspection Standard

Defect Type			Limit			Note		
Visual Defect	Internal	Spot	$\phi < 0.15\text{mm}$		Ignore	(1)		
			$0.15\text{mm} \leq \phi \leq 0.5\text{mm}$		$N \leq 4$			
			$0.5\text{mm} < \phi$		$N=0$			
		Fiber	$0.1\text{mm} < W \leq 0.5\text{mm},$ $L \leq 1.5\text{mm}$		$N \leq 4$	(1)		
			$1.0\text{mm} < W, 1.5\text{mm} < L$		$N=0$			
		Polarizer Bubble	$\phi < 0.15\text{mm}$		Ignore	(1)		
			$0.15\text{mm} \leq \phi \leq 0.5\text{mm}$		$N \leq 4$			
			$0.5\text{mm} < \phi$		$N=0$			
		Mura	It' OK if mura is slight visible through 6%ND filter					
Electrical Defect	Bright Dot	A Grade			B Grade			
		C Area	O Area	Total	C Area	O Area	Total	(3)
		$N \leq 0$	$N \leq 2$	$N \leq 2$	$N \leq 2$	$N \leq 3$	$N \leq 5$	(2)
	Dark Dot	$N \leq 2$	$N \leq 4$	$N \leq 4$	$N \leq 3$	$N \leq 5$	$N \leq 8$	
	Total Dot	$N \leq 4$			$N \leq 5$	$N \leq 6$	$N \leq 8$	(2)
	Two Adjacent Dot	$N \leq 0$	$N \leq 1$ pair	$N \leq 1$ pair	$N \leq 1$ pair	$N \leq 1$ pair	$N \leq 1$ pair	(4)
	Three or More Adjacent Dot	Not Allowed						
	Line Defect	Not Allowed						

(1) One pixel consists of 3 sub-pixels, including R,G, and B dot.(Sub-pixel = Dot)

(2) LITTLE BRIGHT DOT acceptable under 6% ND-Filter

**[Note1]** W : Width[mm], L : Length[mm], N : Number,  $\phi$ : Average Diameter

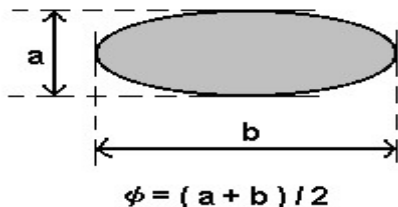

1. (White, black) Spot
2. Polarizer Bubble

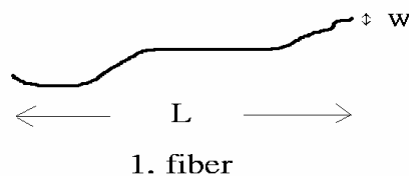

**[Note2]** Bright dot is defined through 6% transmission ND Filter as following.

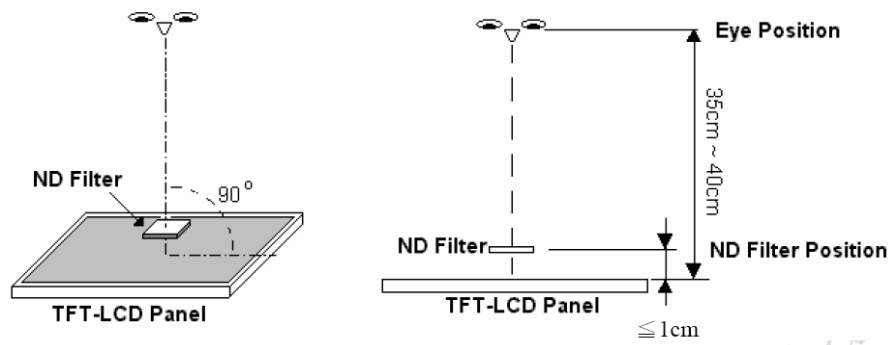

**[Note3]**

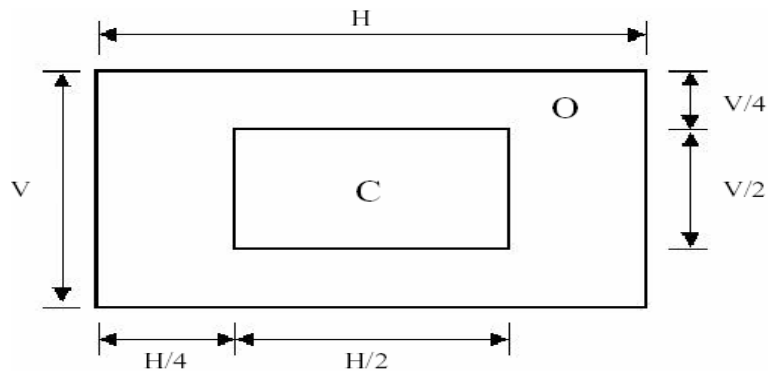

**C Area: Center of display area**

**O Area: Outer of display area**

**[Note4]**

Judge defect dot and adjacent dot as following. Allow below (as A, B, C and D status) adjacent defect dots, including bright and dark adjacent dot. And they will be counted 2

defect dots in total quantity.

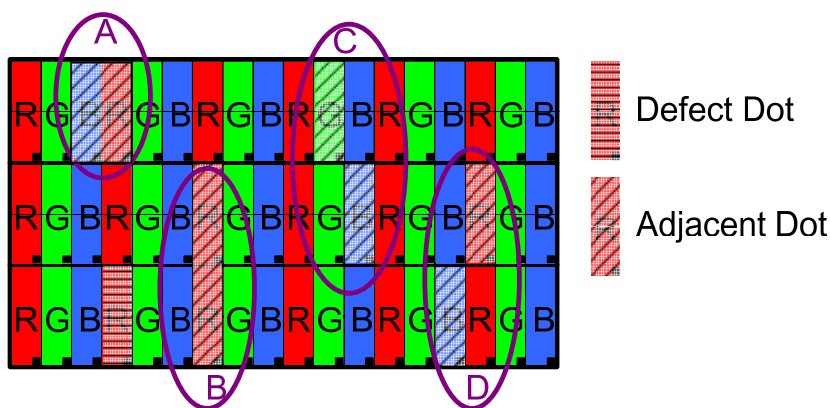

(1) The defects that are not defined above and considered to be problem shall be reviewed and discussed by both parties.

(2) Defects on the Black Matrix, out of Display area, are not considered as a defect or counted.

## 10.6. Reliability Test

Test Item	Test Conditions	Note
High Temperature Operation	70±3°C , t=96 hrs	
Low Temperature Operation	-20±3°C , t=96 hrs	
High Temperature Storage	80±3°C , t=96 hrs	1,2
Low Temperature Storage	-30±3°C , t=96 hrs	1,2
Thermal Shock Test	-20°C ~ 70°C 30 min. ~ 30 min. ( 1 cycle ) Total 100cycle	1,2
Humidity Test	60 °C, Humidity 90%, 240 hrs	1,2
Vibration Test (Packing)	Sweep frequency : 10 ~ 500 ~ 10 Hz/1min Amplitude : 0.75mm Test direction : X.Y.Z/3 axis Duration : 30min/each axis	2

Note 1 : Condensation of water is not permitted on the module.

Note 2 : The module should be inspected after 1 hour storage in normal conditions

(15-35°C , 45-65%RH).

Definitions of life end point :

- Current drain should be smaller than the specific value.
- Function of the module should be maintained.
- Appearance and display quality should not have degraded noticeably.
- Contrast ratio should be greater than 50% of the initial value.

## **11. USE PRECAUTIONS**

### **11.1. Handling precautions**

- 1) The polarizing plate may break easily so be careful when handling it. Do not touch, press or rub it with a hard-material tool like tweezers.
- 2) Do not touch the polarizing plate surface with bare hands so as not to make it dirty. If the surface or other related part of the polarizing plate is dirty, soak a soft cotton cloth or chamois leather in benzine and wipe off with it. Do not use chemical liquids such as acetone, toluene and isopropyl alcohol. Failure to do so may bring chemical reaction phenomena and deteriorations.
- 3) Remove any spit or water immediately. If it is left for hours, the suffered part may deform or decolorize.
- 4) If the LCD element breaks and any LC stuff leaks, do not suck or lick it. Also if LC stuff is stuck on your skin or clothing, wash thoroughly with soap and water immediately.

### **11.2. Installing precautions**

- 1) The PCB has many ICs that may be damaged easily by static electricity. To prevent breaking by static electricity from the human body and clothing, earth the human body properly using the high resistance and discharge static electricity during the operation. In this case, however, the resistance value should be approx. 1M $\Omega$  and the resistance should be placed near the human body rather than the ground surface. When the indoor space is dry, static electricity may occur easily so be careful. We recommend the indoor space should be kept with humidity of 60% or more. When a soldering iron or other similar tool is used for assembly, be sure to earth it.
- 2) When installing the module and ICs, do not bend or twist them. Failure to do so may crack LC element and cause circuit failure.
- 3) To protect LC element, especially polarizing plate, use a transparent protective plate (e.g., acrylic plate, glass etc) for the product case.
- 4) Do not use an adhesive like a both-side adhesive tape to make LCD surface (polarizing plate) and product case stick together. Failure to do so may cause the polarizing plate to peel off.

### **11.3. Storage precautions**

- 1) Avoid a high temperature and humidity area. Keep the temperature between 0°C and 35°C and also the humidity under 60%.
- 2) Choose the dark spaces where the product is not exposed to direct sunlight or fluorescent light.
- 3) Store the products as they are put in the boxes provided from us or in the same conditions as we recommend.

### **11.4. Operating precautions**

- 1) Do not boost the applied drive voltage abnormally. Failure to do so may break ICs. When applying power voltage, check the electrical features beforehand and be careful. Always turn off the power to the LC module controller before removing or inserting the LC module input connector. If the input connector is removed or inserted while the power is turned on, the LC module internal circuit may break.
- 2) The display response may be late if the operating temperature is under the normal standard, and the display may be out of order if it is above the normal standard. But this is not a failure; this will be restored if it is within the normal standard.
- 3) The LCD contrast varies depending on the visual angle, ambient temperature, power voltage etc. Obtain the optimum contrast by adjusting the LC drive voltage.
- 4) When carrying out the test, do not take the module out of the low-temperature space suddenly. Failure to do so will cause the module condensing, leading to malfunctions.
- 5) Make certain that each signal noise level is within the standard (L level: 0.2V<sub>dd</sub> or less and H level: 0.8V<sub>dd</sub> or more) even if the module has functioned properly. If it is beyond the standard, the module may often malfunction. In addition, always connect the module when making noise level measurements.
- 6) The CMOS ICs are incorporated in the module and the pull-up and pull-down function is not adopted for the input so avoid putting the input signal open while the power is ON.
- 7) The characteristic of the semiconductor element changes when it is exposed to light emissions, therefore ICs on the LCD may malfunction if they receive light emissions. To prevent these malfunctions, design and assemble ICs so that they are shielded from light emissions.

8) Crosstalk occurs because of characteristics of the LCD. In general, crosstalk occurs when the regularized display is maintained. Also, crosstalk is affected by the LC drive voltage. Design the contents of the display, considering crosstalk.

#### **11.5. Other**

- 1) Do not disassemble or take the LC module into pieces. The LC modules once disassembled or taken into pieces are not the guarantee articles.
- 2) The residual image may exist if the same display pattern is shown for hours. This residual image, however, disappears when another display pattern is shown or the drive is interrupted and left for a while. But this is not a problem on reliability.
- 3) AMIPRE will provide one year warrantee for all products and three months warrantee for all repairing products.

# 12. OUTLINE DIMENSION

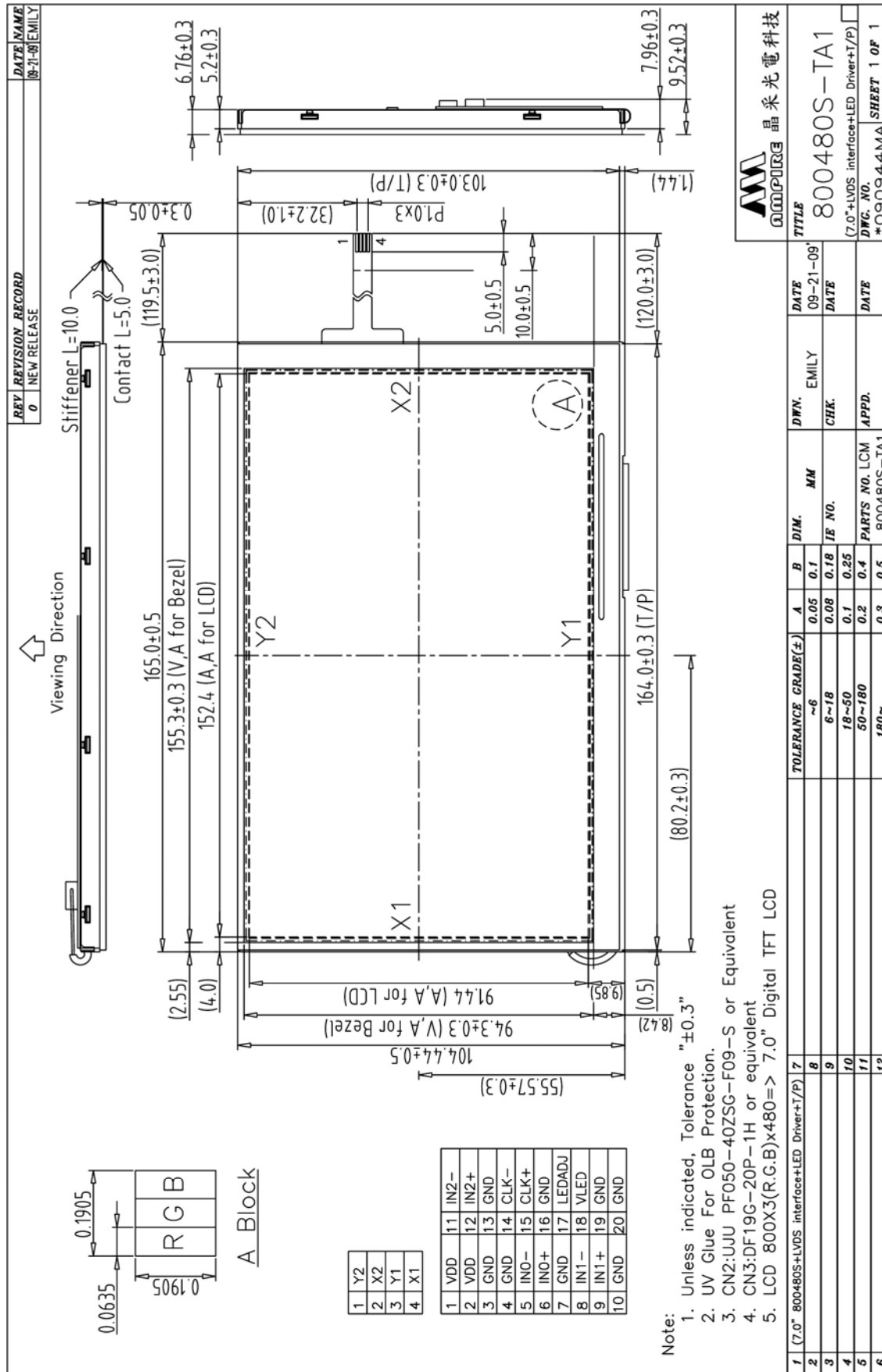

REV	REVISION RECORD	DATE/NAME
0	NEW RELEASE	10-21-09/EMILY

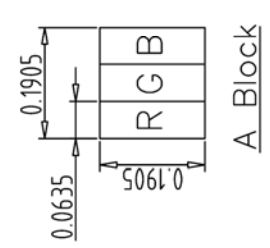
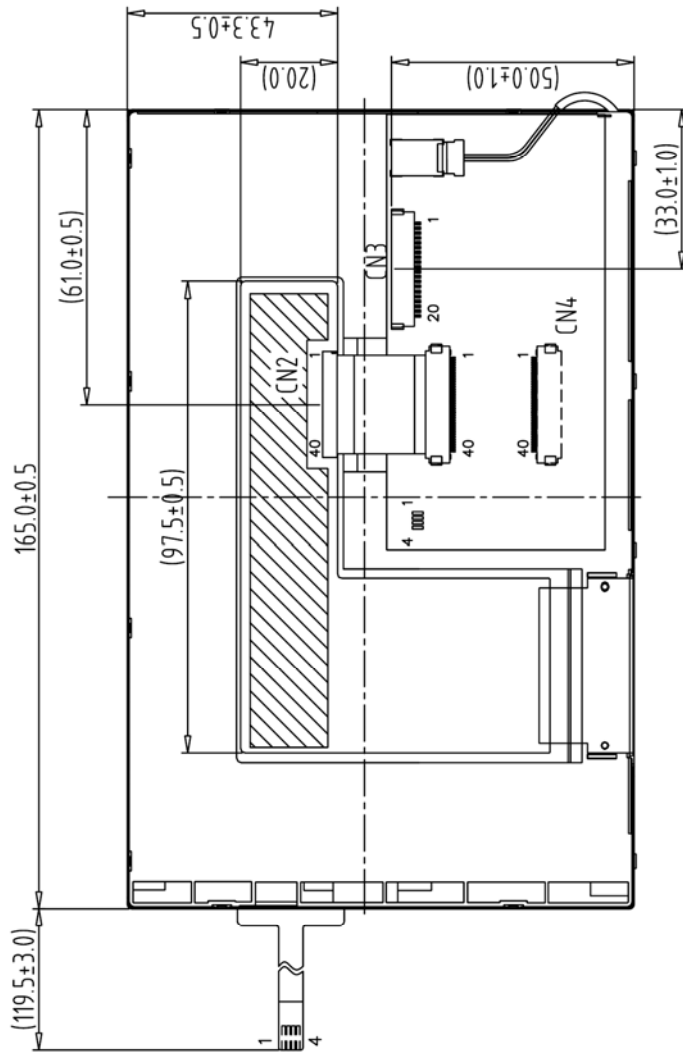

1	VDD	11	IN2-
2	VDD	12	IN2+
3	GND	13	GND
4	GND	14	CLK-
5	IN0-	15	CLK+
6	IN0+	16	GND
7	GND	17	LEDADJ
8	IN1-	18	VLED
9	IN1+	19	GND
10	GND	20	GND

1	Y2
2	X2
3	Y1
4	X1

Back View

- Note:
1. Unless indicated, Tolerance "±0.3"
  2. UV Glue For OLB Protection.
  3. CN2:UJU PF050-40ZSG-F09-S or Equivalent
  4. CN3:DF19G-20P-1H or equivalent
  5. LCD 800X3(R.G.B)x480=> 7.0" Digital TFT LCD

**AMPIRE** 晶采光電科技

TITLE: 800480S-TA1  
 (7.0"+LVDS interface+LED Driver+T/P)

DWG. NO. \*090945MA SHEET 1 OF 1

1	(7.0" 800480S+LVDS interface+LED Driver+T/P)	7	TOLERANCE GRADE(±)	A	B	DIM.	MM	DFN.	DATE
2		8	~6	0.05	0.1	0.18	IE NO.	EMILY	09-21-09
3		9	6~18	0.08	0.18	0.25	PARTS NO.LCM-1	CHK.	DATE
4		10	18~50	0.1	0.25	0.4	800480S-TA1	APPD.	
5		11	50~180	0.2	0.4	0.5			
6		12	180~	0.3	0.5				