



A Brighter Solution

# AMP DISPLAY INC.

## SPECIFICATIONS

### 2.2" TFT MODULE

CUSTOMER:	
CUSTOMER PART NO.	
AMP DISPLAY PART NO.	AM240320JTNQW00H
APPROVED BY:	
DATE:	

APPROVED FOR SPECIFICATIONS

APPROVED FOR SPECIFICATION AND PROTOTYPES

## AMP DISPLAY INC

9856 SIXTH STREET RANCHO CUCAMONGA CA 91730  
TEL: 909-980-13410 FAX: 909-980-1419  
WWW.AMPDISPLAY.COM

## RECORD OF REVISION

<b>Revision Date</b>	<b>Page</b>	<b>Contents</b>	<b>Editor</b>
2006/4/11	-	New Release	Tony
2006/5/22	5	Modify electrical specifications	Tony

# 1 Features

This single-display module is suitable for cellphone application. The Main-LCD adopts one backlight with High brightness 3-lamps white LED.

(1) Main LCD : 1.1 Amorphous-TFT 2.2 inch display, transmissive, Normally white type, 12 o'clock.

1.2 240(RGB) X 320 dots Matrix, 1/320 Duty.

1.3 Narrow-contact ledge technique.

1.4 Main LCD Driver IC: HX8312A

1.5 Real 262K colors display:

65K: Red-5bit, Green-6bit, Blue-5bit (8/16-bit interface)

262K: Red-6bit, Green-6bit, Blue-6bit (9/18-bit interface)

(2) Low cross talk by frame rate modulation

(3) Direct data display with display RAM

(4) Partial display function: You can save power by limiting the display space.

(5) MPU interface: 8bit/16bit/18bit, 80Serial, parallel interface.

(6) RGB interface: 16bit/18bit parallel interface

(7) Abundant command functions:

Area scroll function

Display direction switching function

Power saving function

Electric volume control function: you are able to program the temperature compensation function.

## 2 Mechanical specifications

### Dimensions and weight

Item		Specifications	Unit
External shape dimensions		*66.4 (W) x 40.1 (H) x 3.65 (D) Max.	mm
Main LCD	Pixel pitch	0.1395 (W) x 0.1395(H)	mm
	Active area	33.48 (W) x 44.64 (H)	mm
	Viewing area	35.24 (W) x 46.92 (H)	mm
Weight		15	g

\*1. This specification is about External shape on shipment from AMPIRE.

## 3 Absolute max. ratings and environment

### 3-1 Absolute max. ratings

Ta=25°C GND=0V

Item	Symbol	Min.	Max.	Unit	Remarks
Power voltage	VDD – GND	-0.3	+4.0	V	
Power voltage	LED A – LED K	-0.5	+12.8	V	
Input voltage	VIN	-0.5	VDD+0.5	V	

### 3-2 Environment

Item	Specifications	Remarks
Storage temperature	Max. +70 °C Min. -20 °C	Note 1: Non-condensing
Operating temperature	Max. +60 °C Min. -10 °C	Note 1: Non-condensing

Note 1 : Ta ≤ +40 °C . . . . Max.85%RH

Ta > +40 °C . . . . The max. humidity should not exceed the humidity with 40 °C 85%RH.

## 4 Electrical specifications

### 4-1 Electrical characteristics of LCM

( $V_{DD}=3.0V$ ,  $T_a=25^{\circ}C$ )

Item	Symbol	Conditions	MIN.	TYP.	MAX.	Unit
IC power voltage	$V_{DD}$		2.4	3.0	3.3	V
High-level input voltage	$V_{IHC}$		$0.8V_{DD}$		$V_{DD}$	V
Low-level input voltage	$V_{ILC}$		0		$0.2V_{DD}$	V
Consumption current of VDD	$I_{DD}$	LED OFF	-	4		mA
Consumption current of LED	$I_{LED}$	$V_{LED}=9.6V$	-	15	20	mA

1. 1/320 duty.
2. Electronic Volumn value: (xxxxh) Decimal
3. Thermal Gradient:  $-0.05\%/^{\circ}C$
4. Range of Electronic Volumn control : (xxxxH±3) Decimal

#### 4-2 LED back light specification

Item	Symbol	Conditions	MIN.	TYP.	MAX.	Unit
Forward voltage	$V_f$	$I_f = 15\text{mA}$	9.3	9.8	-	V
Reverse voltage	$V_r$		-	-	12	V
Forward current	$I_f$	3-chip serial	12	15	20	mA
Power Consumption	$P_{BL}$	$I_f = 15\text{mA}$	-	162	-	mW
Uniformity (with L/G)	-	$I_f = 15\text{mA}$	80%*1	-	-	
Bare LED Luminous intensity	$V_f$ $I_f$	9.6V 15mA	2400	-	-	cd/m <sup>2</sup>
Luminous color	White					
Chip connection	3 chip serial connection					

Bare LED measure position:

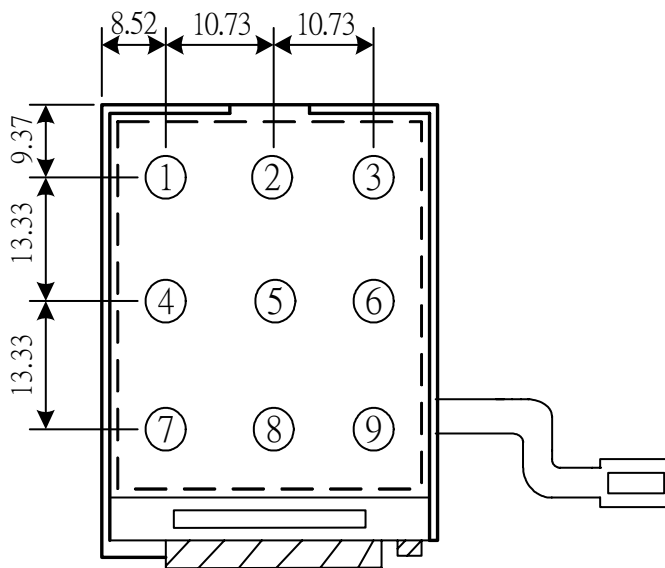

\*1 Uniformity (LT):  $\frac{\text{Min}(P1 \sim P9)}{\text{Max}(P1 \sim P9)} \times 100 \geq 80\%$

## 5 Optical characteristics

### Main LCD

#### 5.1 Optical characteristics

(1/320 Duty in case except as specified elsewhere Ta = 25°C)

LED backlight transmissive module:

Item	Symbol	Temp.	Min.	Std.	Max.	Unit	Conditions
Response time	Tr	25°C	NA	10	25	ms	$\theta = 0^\circ, \varphi = 0^\circ$ (Note 2)
	Tf	25°C	NA	20	40		
Contrast ratio	CR	25°C	150	200	-	-	$\theta = 0^\circ, \varphi = 0^\circ$ LED:ON, LIGHT:OFF (Note 4)
Transmittance	T	25°C	-	6.9	-	%	
Visual angle range front and rear	$\theta$	25°C	( $\theta f$ ) 35 ( $\theta b$ ) 15			De-gree	$\varphi = 0^\circ, CR \geq 10$ LED:ON LIGHT:OFF (Note 3)
Visual angle range left and right	$\theta$	25°C	( $\theta l$ ) 45 ( $\theta r$ ) 45			De-gree	$\varphi = 90^\circ, CR \geq 10$ LED:ON LIGHT:OFF (Note 3)
Visual angle direction priority			12:00				(Note 5)
Brightness			150			Cd/m <sup>2</sup>	V <sub>LED</sub> =9.6V, 15mA Full White pattern

#### 5.2 CIE (x, y) chromaticity (1/320 Duty Ta = 25°C)

Item	Symbol	Transmissive				Conditions
		R G B W Range				
		X1Y1	X2Y1	X1Y2	X2Y2	
Red	XR	0.57	0.57	0.65	0.65	$\theta = 0^\circ, \varphi = 0^\circ$
	YR	0.34	0.40	0.34	0.40	
Green	XG	0.32	0.32	0.38	0.38	$\theta = 0^\circ, \varphi = 0^\circ$
	YG	0.57	0.63	0.57	0.63	
Blue	XB	0.12	0.12	0.18	0.18	$\theta = 0^\circ, \varphi = 0^\circ$
	YB	0.10	0.16	0.10	0.16	
White	Xw	0.28	0.30	0.36	0.37	$\theta = 0^\circ, \varphi = 0^\circ$
	Yw	0.34	0.40	0.34	0.42	

※ The R G B W ranges are for reference.

### LED Dice Bin Code

Color Coordinate @ $I_f = 20\text{mA}$								
Bin Code	1		2		3		4	
	X	Y	X	Y	X	Y	X	Y
<b>E</b>	0.290	0.290	0.290	0.300	0.300	0.310	0.300	0.300
<b>F</b>	0.290	0.280	0.290	0.290	0.300	0.300	0.300	0.290
<b>G</b>	0.290	0.270	0.290	0.280	0.300	0.290	0.300	0.280

**NOTE 1: Optical characteristic measurement system**

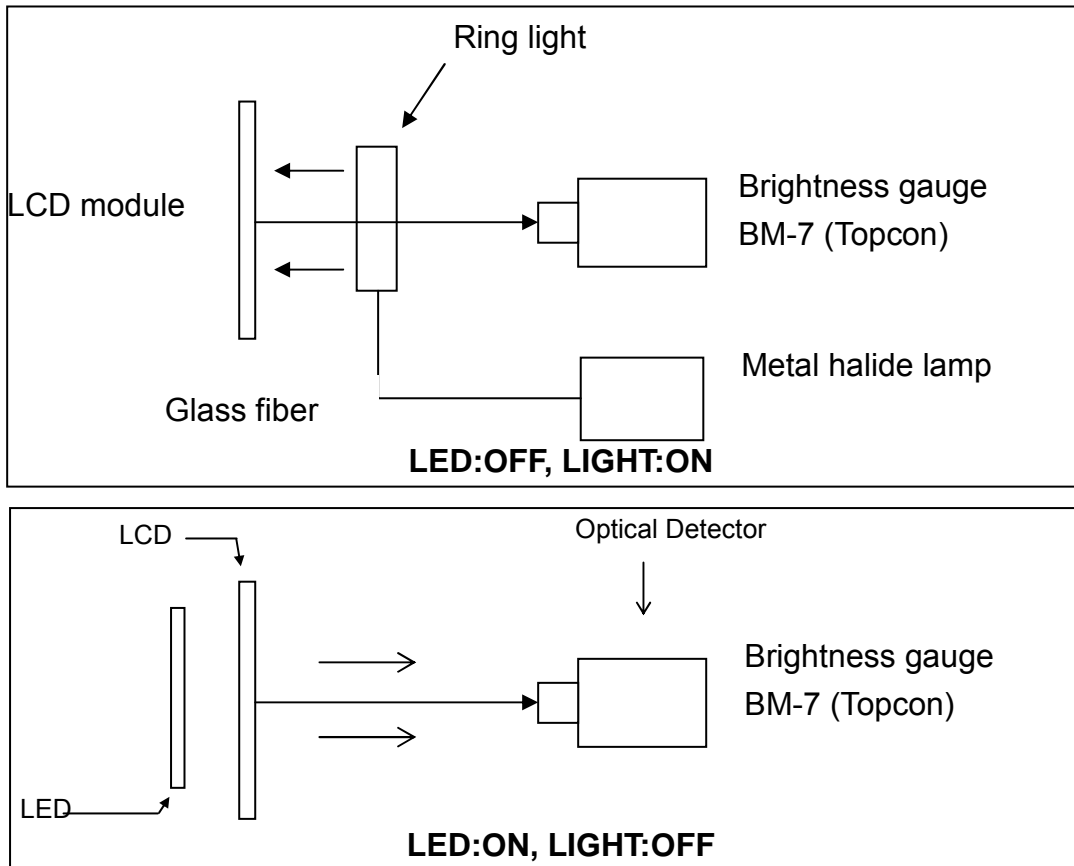

**NOTE 2: Response time definition**

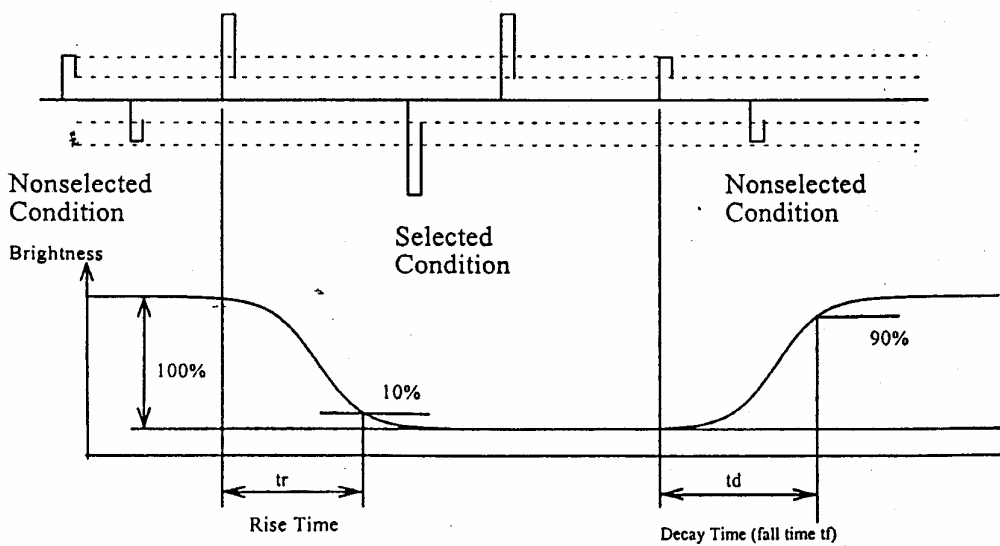

**NOTE 3:  $\phi$ 、 $\theta$  definition**

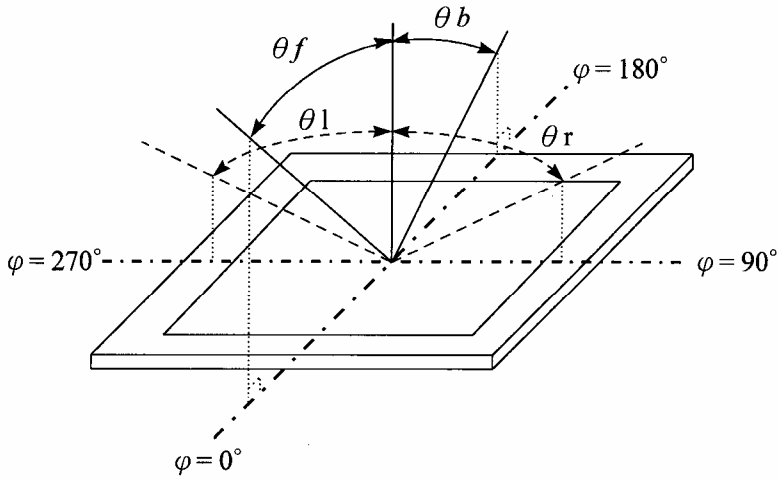

**NOTE 4: Contrast definition**

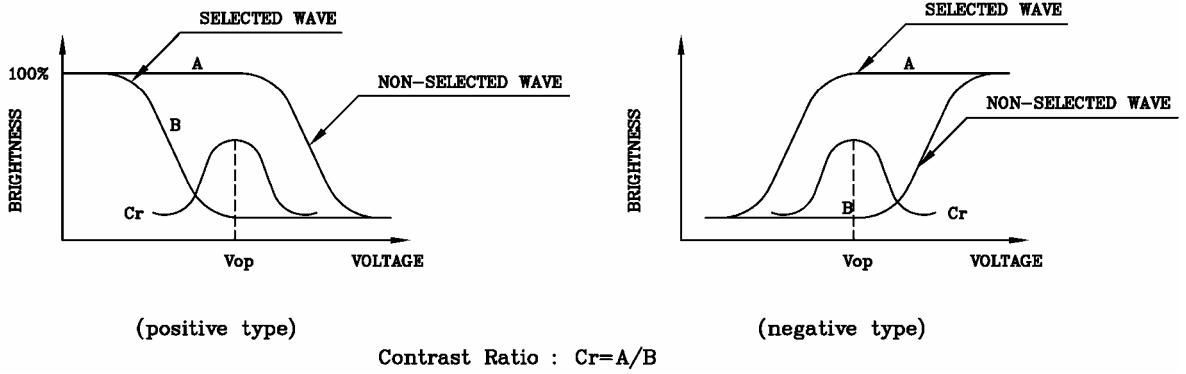

**NOTE 5: Visual angle direction priority**

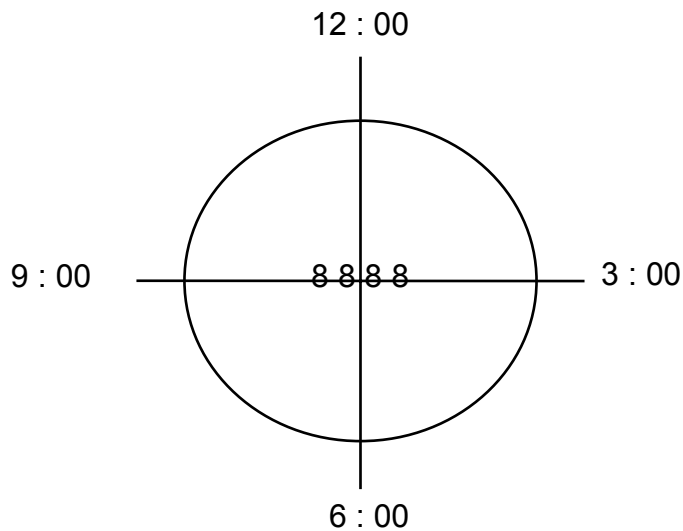

**6 Block Diagram**

**Block diagram (Main LCD)**

Display format: A-Si TFT transmissive, Normally white type, 12 o'clock.  
Display composition: 240 RGB x 320 dots  
LCD Driver : HX8312A  
Back light: White LED x 3 ( $I_{LED}=15mA$ )

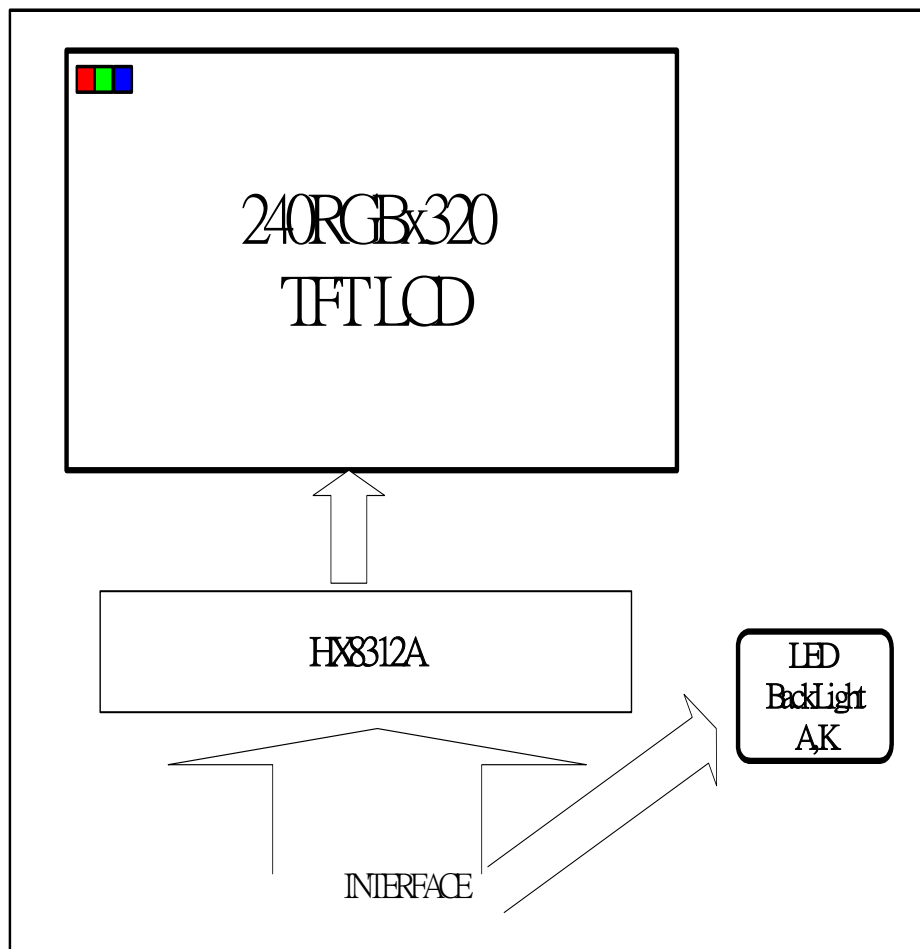

## 7 Interface specifications

Pin No.	Terminal	Functions
1	GND	Ground
2	GND	Ground
3	/CS	Chip Select Signal L : Select
4	/RS	Command/Display Data selection 0: Command , 1: Display Data
5	/WR	Serves As a Write Signal And Writes Data at The rising edge. M68 System:0:Write 1:Read.
6	/RD	I80 System:Serves as a Read Signal and Reads Data at the Low Level. M68 System:0:Write/Read Disable 1:Read.Write
7	RESET	Reset Signal L : Reset
8	D0	18-bit for Data Bus
9	D1	
10	D2	
11	D3	
12	D4	
13	D5	
14	D6	
15	D7	
16	D8	
17	D9	
18	D10	
19	D11	
20	D12	
21	D13	
22	D14	
23	D15	
24	D16	
25	D17	
26	PSX	The Parallel and Serial Bus Interface selection in system interface circuit 0: Parallel Bus Interface, 1: Serial Bus Bus Interface.
27	BWS1	VCC Select Bit Length For CPU.
28	BWS0	VCC Select Bit Length For CPU.
29	DTX2	Ground 16BIT Parallel Data Transfer Method.
30	DTX1	Ground Select Data Length.
31	BWS2	Select Bit Length For RGB(VCC:16BIT GND:18BIT,6BIT)
32	SDI	Serial Data input Pin
33	VCL	Input for Serial Clock
34	VSYNC	Frame Synchronizing Signal
35	HSYNC	Line Synchronizing
36	DOTCLK	Dot Clock Signal

37	NC	No Connect
38	RGB/CPU	Ground Switching For Data Bus 0: System Interface can be accessed. 1: System Interface can Not be accessed.
39	VCC	Power Supply
40	VCI	DC/DC Converter Power

## 7.1 Data format for 8-bit interface

### Data format for 16-bit SDI interface

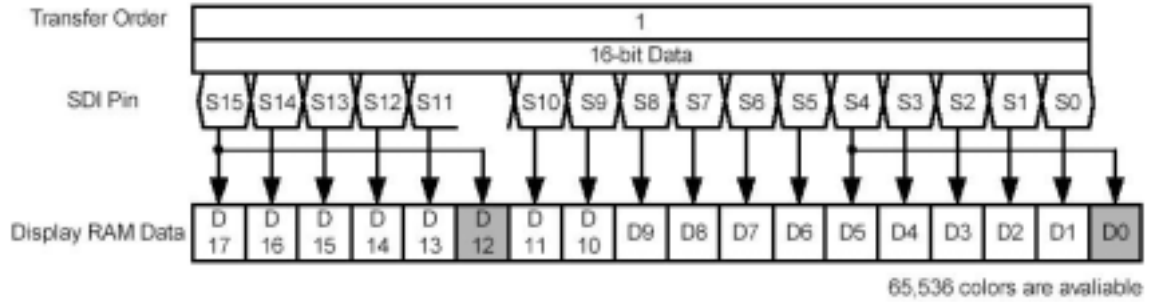

Data format for SDI interface

## 7.2 RGB interface

### 18-bit bus interface

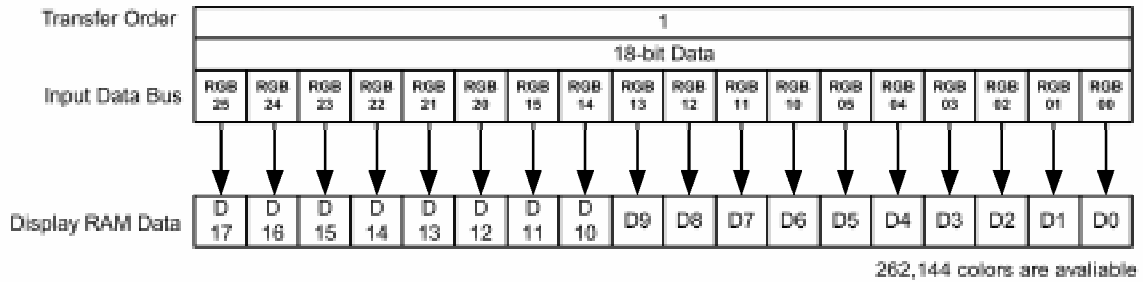

18-bit RGB interface

## 7.3 Instruction Explanation

Input Parts				
Signals	I/O	Pin Number	Connected with	Description
BWS2	I	1	MPU	The bus width selection in RGB interface circuit. 0: 18-bit, 1: 16-bit
BWS1-0		2	MPU	The bus width selection in system interface circuit. (see Table 2.1)
PSX	I	1	MPU	The parallel and serial bus interface selection in system interface circuit. 0: Parallel bus interface, 1: Serial bus interface
NCS	I	1	MPU	Chip select signal. 0: chip can be accessed; 1: chip cannot be accessed.
NRESET	I	1	MPU	Reset pin. Setting either pin low initializes the LSI. Must be reset the chip after power being supplied.
NRD (E)	I	1	MPU	I80 system: Serves as a read signal and reads data at the low level. M58 system: 0: Read/Write disable ; 1: Read/Write enable Fix it to IOVCC or VSSD level when using serial buss interface.
NWR (RnW)	I	1	MPU	Serves as a write signal and writes data at the rising edge. M58 system: 0: Write ; 1: Read Fix it to IOVCC or VSSD level when using serial bus interface.
C86	I	1	MPU	MPU selection 0: i80 series MPU ; 1: M58 series MPU. Fix it to IOVCC or VSSD level when using serial bus interface.
SI	I	1	MPU	Serial bus interface data input pin. Fix it to IOVCC or VSSD level when using parallel bus interface.
SCL	I	1	MPU	Serial bus interface clock input pin Fix it to IOVCC or VSSD level when using parallel bus interface.
RGB_nCPU	I	1	MPU	0: System interface can be accessed. 1: System interface can not be accessed.
RS	I	1	MPU	Command/display Data Selection 0: Command, 1: Display data Connect to IOVCC or VSSD level when serial bus interface is selected.
DTX2-1	I	2	MPU	Specify the transferring method of one pixel data in system interface. (see Table 2.3)
SCLEG1-0	I	1	MPU	Determine the effective edge operation of SCLK for SDI data latch and SDO data output. (see Table 2.6)
VSYNC	I	1	MPU	Vertical synchronization signal input pin. Must be connected to IOVCC if not in use.
HSYNC	I	1	MPU	Horizontal synchronization signal input pin. Must be connected to IOVCC if not in use.
DOTCLK	I	1	MPU	Dot clock signal input used in the RGB interface circuit. Must be connected to IOVCC if not in use.
ENABLE	I	1	MPU	Enable signal pin used in RGB interface circuit 0: disable, 1: enable when EPL (D1 bit of R157) = 0. 0: enable, 1: disable when EPL (D1 bit of R157) = 1. Must be connected to IOVCC if not in use.
VSEG	I	1	MPU	Valid VSYNC polarity selection pin 0: Start in the low level, 1: Start in the high level
HSEG	I	1	MPU	Valid HSYNC polarity selection pin 0: Start in the low level, 1: Start in the high level.
DCKEG	I	1	MPU	Valid DOTCLK polarity selection pin 0: falling edge latch, 1: rising edge latch
DDS	I	1	MPU	Selection the position of dummy line (321st line). 0: the end of the frame, 1: the beginning of the frame

Output Part				
Signals	I/O	Pin Number	Connected with	Description
SO	O	1	MPU	Serial bus interface data output pin. Keep it open while using parallel bus interface
CSTB	O	1	MPU	Frame synchronization signal output pin. Keep it open if not in use.
S1-S720	O	720	LCD	Source driver output pin. Output voltages to the liquid crystal.
G1-G321	O	321	LCD	Output signals to panel gate lines. VGH: the level to select the gate lines VGL: the level not to select the gate lines
VCOM1-4	O	4	LCD	VCOM output pin. They are short-circuited inside HX8312A.

Input/Output Part				
Signals	I/O	Pin Number	Connected with	Description
DB17-0	I/O	18	MPU	Operates liked an 18-bit bi-directional data bus. Fix it to IOVCC or VSSD level when using serial bus interface. Don't set MPU output as Hi-Z when MPU has no output.
OSC2-1	I/O	2	Oscillation Resistor	Connect an external resistor for generating internal clock by internal R-C oscillation. Or an external clock signal is supplied through OSC1 with OSC2 open.
C11A , C11B CX11A , CX11B	I/O	4	Step up Capacitor	Connect to the step-up capacitors for step up circuit 1 operation. Leave this pin open if the internal step-up circuit is not used.
C21A , C21B C22A , C22B C23A , C23B	I/O	6	Step up Capacitor	Connect to the step-up capacitors for step up circuit 2 operation. Leave this pin open if the internal step-up circuit is not used.
C12A , C12B	I/O	2	Step up Capacitor	Connect to the step-up capacitors for step up circuit 3 operation. Leave this pin open if the internal step-up circuit is not used.

Power Part				
Signals	I/O	Pin Number	Connected with	Description
VCC	I	1	Power supply	A power supply for the internal logic circuit. VCC = 2.2 ~ 3.3V
VCI	I	1	Power supply	A Power supply for step-up circuit and power supply circuit. VCI = 2.5 ~ 3.3V
IOVCC	I	1	Power supply	Power supply for I/O circuit. IOVCC = 1.65 ~ 3.3V
V18	O	1	Bypass capacitor and VDDD, RVCC	1.8V regulator output. V18, VDDD and RVCC must have the same voltage level. Connect to VDDD and RVCC on the FPC.
RVCC	I	1	V18 and VDDD	Power supply for RAM circuit.
VDDD	I	1	V18 and RVCC	Power supply for logic circuit.
VSSD	I	1	Power supply	Ground for digital circuit.
VSSA	I	1	Power supply	Ground for analog circuit.
VGH	O	1	Bypass Capacitor	A positive power supply for the gate line drive circuit.
VGL	O	1	Bypass Capacitor Schottky Diode	A negative power supply for the gate line drive circuit. Insert a schottky diode in a forward direction to VSSA.
ADDVDH	I	1	DDVDH	Power supply pins for VS and COMH regulators. Connected to DDVDH on FPC
DDVDH	O	1	ADDVDH and Bypass Capacitor	Output supply pin. Connected to ADVDDH on FPC.
VDH	O	1	Bypass Capacitor	Power supply for the source drive unit.
VCL	O	1	Bypass Capacitor	The voltage of Vci x (-1) output
VR2-1	O	2	Bypass Capacitor	Reference voltage output for the step-up circuit 2.
VS	O	1	Bypass Capacitor	Power supply for the source drive unit.
VGLDMY	O	1	---	A negative power supply for the gate line drive circuit.

## 7.4 Register Description

Register	Bit	Symbol	Function	Configuration
<b>Control register 1</b>				
<b>R0 (R00h)</b>  <b>default "A0"h</b>	D7	DISP1	Source output data selection.	All source output as "0" or "1" selection Refer to "10.2 " All "0" or "1" Source Output Display "
	D6	DISP0	Source output data selection.	All source output as "0" or "1" selection Refer to "10.2 " All "0" or "1" Source Output Display "
	D5	ADC	Specifies source output and display RAM address mapping .	Refer to 4.1 "Relation between the Display RAM Address and the Source Output Channel"
	D4	DTY	Specifies partial display mode.	"0": Normal display mode. "1": Partial display mode. Refer to "5. Partial Display Mode".
	D3	STBY	Specifies stand-by mode.	"0": Normal operation. "1": Stand-by mode.
	D2	COLOR	Specifies color mode.	"0": 262,144 color mode. "1": 8 color mode. Refer to "9 8-color Display Mode".
	D1	-	-	-
	D0	GSM	Gate scan selection in partial-off display areas.	"0": Normal scan in non-display area "1": Configures the scanning cycle in non-display area by the number of the R52 register.
<b>Control register 2</b>				
<b>R1 (R01h)</b>  <b>default "00"h</b>	D7	ADX	RAM X address increment direction after one write or read operation .	"0": From X0 to X239 Refer to "4.2. Display RAM Access" "1": From X239 to X0 *Note : ADX = "1" setting is prohibited when RGB interface circuit is in use.
	D6	ADR	RAM Y address increment direction after one write or read operation .	"0": Y0 to Y319 Refer to "4.2. Display RAM Access" "1": Y319 to Y0 *Note : ADR = "1" setting is prohibited when RGB interface circuit is in use.
	D5	-	-	-
	D4	-	-	-
	D3	-	-	-
	D2	-	-	-
	D1	LTS	Specifies setting period of calibration.	"0": 1line period = tcal "1": 1 line period = tcal x 2 Refer to "3.3 Internal Clock Mode".
	D0	OSCSTBY	Oscillation control.	"0": Starts oscillation. "1": Stops oscillation.
<b>RGB interface register 2</b>				
<b>R2 (R02h)</b>  <b>default "00"h</b>	D7	-	-	-
	D6	-	-	-
	D5	-	-	-
	D4	VMODE	Vsync interface selection.	"0": Normal Refer to "Table 9-1". "1": Uses Vsync interface.
	D3	WNRGB	RGB interface writing mode selection.	"0": Requires 1 frame data. "1": Requires data only for the window area. Refer to "9.1.6 Restriction when using the RGB interface circuit".
	D2	RGBS	RGB interface writing mode selection.	"0": Capture mode. Refer to "Table 9-1". "1": Through mode.
	D1	DISPCK	Specifies display timing at RGB interface circuit.	"0": Internally synchronized display mode by SYSCLK. "1": Externally synchronized display mode by Vsync and Hsync. Refer to "Table 9-1".
	D0	NWRGB	RGB interface pin control.	"0": Writes to the display data RAM via the system interface circuit. "1": Writes to the display data RAM via the RGB interface circuit. Refer to "Table 9-1".

Reset register 1				
R3 (R03h)	D7	-	-	-
	D6	-	-	-
	D5	-	-	-
	D4	-	-	-
	D3	-	-	-
	D2	-	-	-
	D1	-	-	-
	D0	RES	Reset command for the HX8312A	"0" : Normal operation. "1" : Reset Operation.
RAM access control register				
R5 (R05h)	D7	-	-	-
	D6	-	-	-
	D5	-	-	-
	D4	WAS	Specifies window area access mode.	"0" : Normal writing mode. "1" : Window area access mode. Refer to "4.3. Window Area Access Mode".
	D3	-	-	-
	D2	AM	Specifies the address increment direction.	"0" : X address increment, then Y address increment. "1" : Y address increment, then X address increment. *Note: This setting is invalid when RGB interface circuit is in use. Refer to "4.2. Access to the Display Data RAM".
	D1	-	-	-
	D0	-	-	-
Data reverse register				
R6 (R06h)	D7	-	-	-
	D6	-	-	-
	D5	-	-	-
	D4	-	-	-
	D3	-	-	-
	D2	-	-	-
	D1	-	-	-
	D0	REV	Reverse the source output data voltage	"0": Data "0000" h; Source output: V83 at VCOML "1": Data "0000" h; Source output: V0 at VCOML
Display size control register				
R13 (R0Dh)	D7	-	-	-
	D6	-	-	-
	D5	-	-	-
	D4	-	-	-
	D3	-	-	-
	D2	NSO1	Specify source output size.	Refer to "4.1 Relation between the Display RAM Address and the Source Output Channel".
	D1	NSO0		
	D0	-	-	-
Partial non-display area color register 1				
R14 (R0Eh)	D7	-	-	-
	D6	-	-	-
	D5	-	-	-
	D4	-	-	-
	D3	-	-	-
	D2	-	-	-
	D1	-	-	-
	D0	PSEL	Specifies the color of the partial non-display area	"0" : Displays the color specified in the R15 register. "1" : Displays the most significant bit of the display RAM data. Refer to "5.2 Display Color Selection and Gate Scan Method in Partial Non-Display Areas".

Partial non-display area color register 2				
R15 (0F'h)	D7	-	-	-
	D6	-	-	-
	D5	-	-	-
	D4	-	-	-
	D3	-	-	-
	D2	PGR	Specifies display data for pixel R.	"0" : Displays "0". "1" : Displays "1".
	D1	PGG	Specifies display data for pixel G.	"0" : Displays "0". "1" : Displays "1".
default "00'h	D0	PGB	Specifies display data for pixel B.	"0" : Displays "0". "1" : Displays "1".
First display window area starting register 1 , 2				
R16 (R10h)	D7	-	-	-
	D6	-	-	-
	D5	-	-	-
	D4	-	-	-
	D3	-	-	-
	D2	-	-	-
	D1	-	-	-
R17 (R11h)	D0	P1SL8	Specify the starting line number of the first display window area.	Set within the range of *000'h - *13F'h.
	D7	P1SL7		
	D6	P1SL6		
	D5	P1SL5		
	D4	P1SL4		
	D3	P1SL3		
	D2	P1SL2		
default "00'h	D1	P1SL1		
D0	P1SL0			
Second display window area starting register 1 , 2				
R18 (R12h)	D7	-	-	-
	D6	-	-	-
	D5	-	-	-
	D4	-	-	-
	D3	-	-	-
	D2	-	-	-
	D1	-	-	-
R19 (R13h)	D0	P2SL8	Specify the starting line number of the second display window area.	Set within the range of *000'h - *13F'h.
	D7	P2SL7		
	D6	P2SL6		
	D5	P2SL5		
	D4	P2SL4		
	D3	P2SL3		
	D2	P2SL2		
default "00'h	D1	P2SL1		
D0	P2SL0			
First display window area display line number 1 , 2				
R20 (R14h)	D7	-	-	-
	D6	-	-	-
	D5	-	-	-
	D4	-	-	-
	D3	-	-	-
	D2	-	-	-
	D1	-	-	-
R21 (R15h)	D0	P1AW8	Specify the display line number of the first display window area.	Set within the range of *001'h - *140'h.
	D7	P1AW7		
	D6	P1AW6		
	D5	P1AW5		
	D4	P1AW4		
	D3	P1AW3		
	D2	P1AW2		
default "00'h	D1	P1AW1		
D0	P1AW0			

Second display window area display line number 1, 2					
R22 (R16h)	D7	-	-	-	
	D6	-	-	-	
	D5	-	-	-	
	D4	-	-	-	
	D3	-	-	-	
	D2	-	-	-	
	D1	-	-	-	
	D0	P2AWB			
R23 (R17h)	D7	P2AW7	Specify the display line number of the second display window area.	Set within the range of 000'h - '13F'h.	
	D6	P2AW6			
	D5	P2AW5			
	D4	P2AW4			
	D3	P2AW3			
	D2	P2AW2			
	D1	P2AW1			
	D0	P2AW0			
Power Supply System Control Register 1					
R24 (R18h)	D7	VR2ON	Controls the VR2 regulator.	"0": VR2 regulator off. "1": VR2 regulator on.	
	D6	VR1ON	Controls the VR1 regulator.	"0": VR1 regulator off. "1": VR1 regulator on.	
	D5	VCLON	Controls the step-up circuit 3 for VCL..	"0": VCL step-up circuit off. "1": VCL step-up circuit on.	
	D4	VGON	Controls the step-up circuit 2.	"0": Step-up circuit 2 off. "1": Step up circuit 2 on.	
	D3				
	D2	DDVDHON	Controls the step-up circuit 1 for DDVDH.	"0": DDVDH step-up circuit off. "1": DDVDH step-up circuit on.	
	D1				
	D0	DCON	Controls the DC/DC converter.	"0": DC/DC converter off. "1": DC/DC converter on.	
Power Supply System Control Register 2					
R25 (R19h)	D7	VR2SEL2	Specify the output voltage of the VR2 regulator.	-	
	D6	VR2SEL1			
	D5	VR2SEL0			
	D4	VR1SEL2	Specify the output voltage of the VR1 regulator.		
	D3	VR1SEL1			
	D2	VR1SEL0			
	D1	-	-		-
	D0	-	-		-
Power Supply System Control Register 3					
R26 (R1Ah)	D7	-	-	-	
	D6	-	-	-	
	D5	-	-	-	
	D4	-	-	-	
	D3	FS3	Specify the step-up circuit 2 and 3 frequency	-	
	D2	FS2			
	D1	FS1	Specify the step-up circuit 1 frequency		
	D0	FS0			
Power Supply System Control Register 4					
R27 (R1Bh)	D7	-	-		-
	D6	-	-		-
	D5	-	-		-
	D4	-	-	-	
	D3	VSEL2	Specify the output voltage of the VS and VDH regulator.	-	
	D2	VSEL1			
	D1	VSEL0			
	D0	RGON	Controls the VS and VDH regulator.		"0": VS and VDH regulator off. "1": VS and VDH regulator on.

Power Supply System Control Register 5				
R28 (R1Ch)	D7	-	-	
	D6	SAP2	Source driver circuit operating current control	
	D5	SAP1		
	D4	SAP0		
	D3	-	-	-
	D2	AP2	Step-up circuit operating current control	(AP2, AP1, AP0) = "000": Halt (AP2, AP1, AP0) = "001": 0.5(fixed) (AP2, AP1, AP0) = "010": 0.75(fixed) (AP2, AP1, AP0) = "011": 1.0(fixed) (AP2, AP1, AP0) = "100": 1.25(fixed) (AP2, AP1, AP0) = "101": 1.5(fixed) (AP2, AP1, AP0) = "110": 1.5(fixed) (AP2, AP1, AP0) = "111": Setting disable
	D1	AP1		
	D0	AP0		
Power Supply System Control Register 6				
R29 (R1Dh)	D7	-	-	
	D6	-	-	
	D5	-	-	
	D4	-	-	
	D3	R/L	Specifies the gate scan direction.	-
	D2	SCN2	Specify gate scan mode.	(SCN2, SCN1, SCN0) = "XX0": MODE5 (SCN2, SCN1, SCN0) = "011": MODE2
	D1	SCN1		
	D0	SCN0		
Power Supply System Control Register 8				
R30 (R1Eh)	D7	VCOMEN	Specify the VCOM1 operation.	-
	D6	-		
	D5	VCOMFX		
	D4	VCOMHI		
	D3	XVCOMG	VCOML output control	"0": VCOML = GND "1": VCOML is setting with VDV and VCM
	D2	-	-	-
	D1	-	-	-
	D0	DDVDHXON	Specifies whether to use or not to use the extra step-up circuit 1 for DDVDH.	"0": Doesn't use the extra step-up circuit 1. "1": Uses the extra step-up circuit 1.
Power Supply System Control Register 9				
R31 (R1Fh)	D7	-	Specify the VCOM amplitude.	-
	D6	-		
	D5	-		
	D4	VDV4		
	D3	VDV3		
	D2	VDV2		
	D1	VDV1		
	D0	VDV0		
Power Supply System Control Register 10				
R32 (R20h)	D7	-	Specify the VCOMH voltage level	-
	D6	-		
	D5	-		
	D4	VCM4		
	D3	VCM3		
	D2	VCM2		
	D1	VCM1		
	D0	VCM0		

				<b>ID code register 1</b>			
<b>R49</b> <b>(R31h)</b>	D7	MCOD3	Manufacturer code.	-			
	D6	MCOD2					
	D5	MCOD1					
	D4	MCOD0					
default "10"h	D3	VCOD3	The version of this LSI.	Depends on the version of the product.			
	D2	VCOD2					
	D1	VCOD1					
	D0	VCOD0					
				<b>ID code register 2</b>			
<b>R50</b> <b>(R32h)</b>	D7	DCOD7	Device code of this LSI.	-			
	D6	DCOD6					
	D5	DCOD5					
	D4	DCOD4					
default "03"h	D3	DCOD3					
	D2	DCOD2					
	D1	DCOD1					
	D0	DCOD0					
				<b>N line inversion register</b>			
<b>R51</b> <b>(R33h)</b>	D7	NLINE6	Specify the number of lines for N line inversion.	Set within the range of "01"h - "78"h. Refer to "7 Gate Line Driving Function".			
	D6	NLINE5					
	D5	NLINE4					
	D4	NLINE3					
default "01"h	D3	NLINE2					
	D2	NLINE1					
	D1	NLINE0					
	D0	NLINE0					
				<b>Partial gate register 1</b>			
<b>R52</b> <b>(R34h)</b>	D7	GSMLN7	Specify the gate scanning cycle of the non-display area	"00"h : Doesn't scan the partial non-display area. "01"h : Scans the partial non-display area every frame. "02"h : Scans the partial non-display area every two frames.			
	D6	GSMLN6					
	D5	GSMLN5					
	D4	GSMLN4					
default "01"h	D3	GSMLN3					
	D2	GSMLN2					
	D1	GSMLN1					
	D0	GSMLN0					
				<b>Partial gate register 2</b>			
<b>R53</b> <b>(R35h)</b>	D7	-	-	-			
	D6	-	-	-			
	D5	-	-	-			
	D4	-	-	-			
default "00"h	D3	-	-	-			
	D2	-	-	-			
	D1	-	-	-			
	D0	PNFRM	Configures the driving method of the partial non-display area.	"0" : The partial non-display area is driven as that in the partial display area. "1" : The partial non-display area is driven by the frame inversion.			
				<b>Gate scan selection register</b>			
<b>R55</b> <b>(R37h)</b>	D7	-	-	-			
	D6	-	-	-			
	D5	-	-	-			
	D4	-	-	-			
default "00"h	D3	-	-	-			
	D2	GSCAN2	Select the method of gate scanning.	-			
	D1	GSCAN1					
	D0	GSCAN0					
				<b>Gate output control register</b>			
<b>R59</b> <b>(R3Bh)</b>	D7	-	-	-			
	D6	-	-	-			
	D5	-	-	-			
	D4	-	-	-			
default "00"h	D3	-	-	-			
	D2	-	-	-			
	D1	-	-	-			
	D0	DISPTMG	Controls the gate output	"0" : Fix all gate outputs to VGL level. "1" : Gate scanning normal operation.			

Gamma control register 12				
R154 (R9Ah)  default "00"h	D7	-	Gamma adjustment register	-
	D6	-		
	D5	-		
	D4	ON14		
	D3	ON13		
	D2	ON12		
	D1	ON11		
	D0	ON10		
Extend mode register				
R157 (R9Dh)  default "00"h	D7	-	-	-
	D6	-	-	-
	D5	MON_EN	Specify the V0 and V63 monitor function	"0": V0 and V63 output monitor is disable. "1": V0 and V63 output monitor is enable.
	D4	MON_SEL	V0 and V63 monitor selection	"0": V0 outputs at DS1 pin. "1": V63 outputs at DS1 pin
	D3	-	-	-
	D2	BPEN	Specify the Enable operation	"0": Enable control is available. "1": VBP/HBP control is enable
	D1	EPL	Specify the Enable polarity	"0": High active "1": Low active
	D0	MSBF	NWRGB (R2:D0) = "1"	"0": 18-bit x 1transfer ( BWS2="L" ). RGB interface type "0": 16-bit x 1transfer ( BWS2="H" ). RGB interface type "1": 6-bit x 3 transfer ( BWS2=x ). RGB interface type
	NWRGB (R2:D0) = "0"		"0": MPU5 mode A ( use lower 6bits ). MPU interface type "1": MPU5 mode B ( use upper 6bits ). MPU interface type This bit is invalid in other modes.	
Off mode register				
R192 ("C0"h)  default "00"h	D7	OFFMOD	Specify the Off mode	"0": Normal mode "1": Off mode In off mode, only OFFMOD bit can be updated. Other register and the display RAM can not be updated. The display RAM data may not be retained in off mode, and need to rewrite after off mode canceling.
	D6	-	-	-
	D5	-	-	-
	D4	-	-	-
	D3	-	-	-
	D2	-	-	-
	D1	-	-	-
	D0	-	-	-

## 8 Timing Characteristics

### 8.1 Timing Characteristics

Read / Write Characteristics (8080-series MPU)

Bus Timing Characteristics

<<Normal Write Mode (IoVcc=1.65V-2.4V)/VCC=2.4~3.3V>>

Item		Symbol	Unit	Min	Typ	Max
Bus cycle time	Write	tCYCW	ns	200	-	-
	Read	tCYCR	ns	300	-	-
Write low-level pulse width		PWLW	ns	40	-	-
Read low-level pulse width		PWLR	ns	150	-	-
Write high-level pulse width		PWHW	ns	70	-	-
Read high-level pulse width		PWHR	ns	150	-	-
Write/Read rise/fall time		tWRr,WRf	ns	-	-	25
Set up time	(RS to NCS,E_NWR)	tAS	ns	5	-	-
	(RS to NCS,RE_NRD)		ns	5	-	-
Address hold time		tAH	ns	5	-	-
Write data set up time		tDSW	ns	20	-	-
Write data hold time		tH	ns	15	-	-
Read data delay time		tDDR	ns	-	-	100
Read data hold time		tDHR	ns	5	-	-

<< Normal Write Mode , (IoVcc=2.4V-3.3V)/VCC=2.4~3.3V>>

Item		Symbol	Unit	Min	Typ	Max
Bus cycle time	Write	tCYCW	ns	125	-	-
	Read	tCYCR	ns	300	-	-
Write low-level pulse width		PWLW	ns	40	-	-
Read low-level pulse width		PWLR	ns	150	-	-
Write high-level pulse width		PWHW	ns	70	-	-
Read high-level pulse width		PWHR	ns	150	-	-
Write/Read rise/fall time		tWRr,WRf	ns	-	-	25
Set up time	(RS to CS*,WR*)	tAS	ns	5	-	T.B.D
	(RS to RD*)		ns	5	-	-
Address hold time		tAH	ns	5	-	-
Write data set up time		tDSW	ns	20	-	-
Write data hold time		tH	ns	15	-	-
Read data delay time		tDDR	ns	-	-	100
Read data hold time		tDHR	ns	5	-	-

## Read / Write Characteristics (68-system MPU)

### Bus Timing Characteristics

<<Normal Write Mode(HWM=0),IoVcc = 2.4V-3.3V>>

Item		Symbol	Unit	Min	Typ	Max
Bus cycle time	Write	tCYCW	ns	200	-	-
	Read	tCYCR	ns	300	-	-
Write low-level pulse width		PWLW	ns	70	-	-
Read low-level pulse width		PWLR	ns	150	-	-
Write high-level pulse width		PWHW	ns	40	-	-
Read high-level pulse width		PWHR	ns	150	-	-
Write/Read rise/fall time		tWRr,WRf	ns	-	-	25
Set up time	(RS to NCS,E_NWR)	tAS	ns	5	-	-
	(RS toNCS,RE_NRD)		ns	5	-	-
Address hold time		tAH	ns	5	-	-
Write data set up time		tDSW	ns	20	-	-
Write data hold time		tH	ns	15	-	-
Read data delay time		tDDR	ns	-	-	100
Read data hold time		tDHR	ns	5	-	-

<< Normal Write Mode , (IoVcc=2.4V-3.3V)/VCC=2.4~3.3V>>

Item		Symbol	Unit	Min	Typ	Max
Bus cycle time	Write	tCYCW	ns	125	-	-
	Read	tCYCR	ns	300	-	-
Write low-level pulse width		PWLW	ns	70	-	-
Read low-level pulse width		PWLR	ns	200	-	-
Write high-level pulse width		PWHW	ns	40	-	-
Read high-level pulse width		PWHR	ns	200	-	-
Write/Read rise/fall time		tWRr,WRf	ns	-	-	25
Set up time	(RS to CS*,WR*)	tAS	ns	10	-	-
	(RS to RD*)		ns	10	-	-
Address hold time		tAH	ns	5	-	-
Write data set up time		tDSW	ns	60	-	-
Write data hold time		tH	ns	15	-	-
Read data delay time		tDDR	ns	-	-	100
Read data hold time		tDHR	ns	5	-	-

### Reset Timing Characteristics

Item	Symbol	Unit	Min	Typ	Max
Reset"low"level width	tRES	ms	(1)	-	-
Reset rise time	trRES	us	-	-	(10)

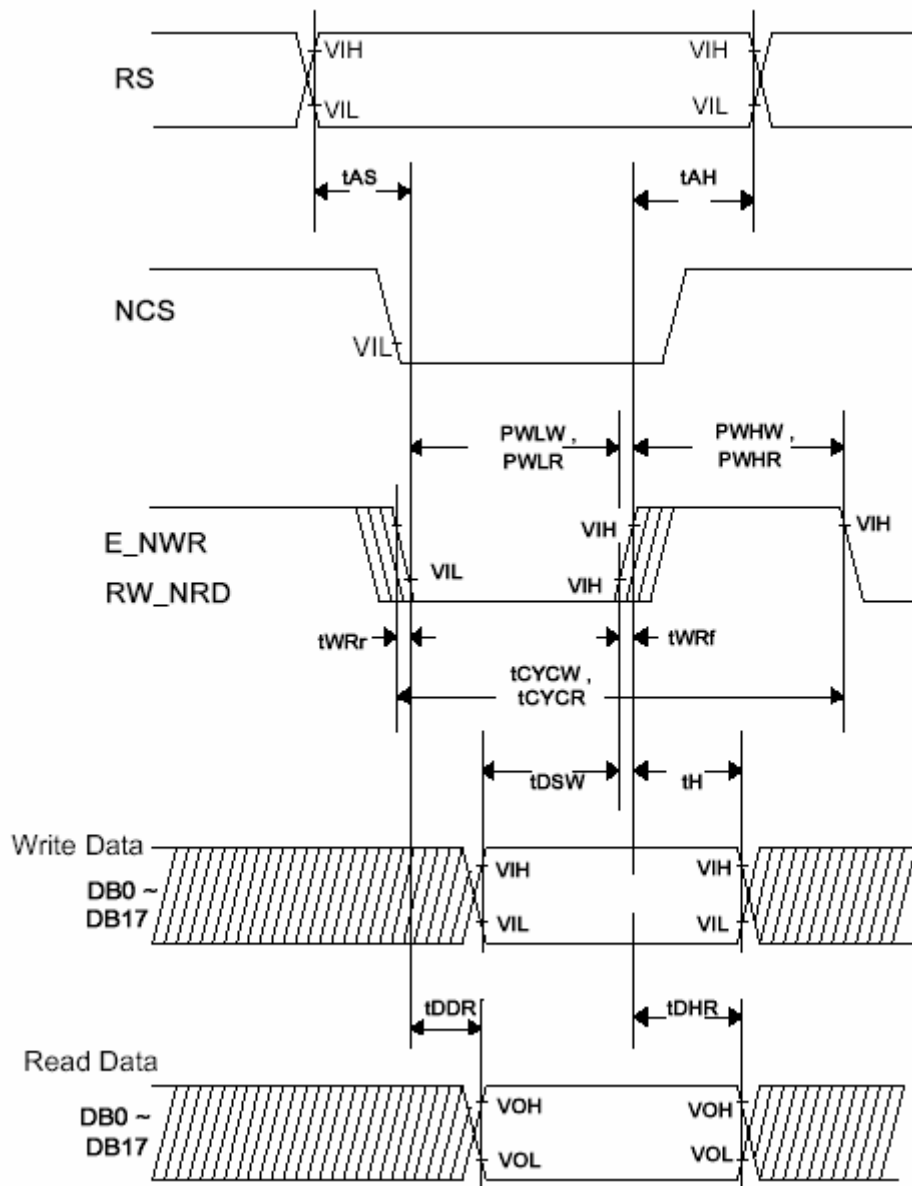

80-System Bus Timing

Note 1) PWEL is specified during the overlap period. (SC\*="Low", WR\* or RD\*="Low")

Note 2) When using 16-bit bus interface, parallel data can be transferred through DB17-10 pin and DB8-1 and DB0 must be fixed to "Vcc" or "GND".

## 9 SETUP FLOW OF POWER SUPPLY

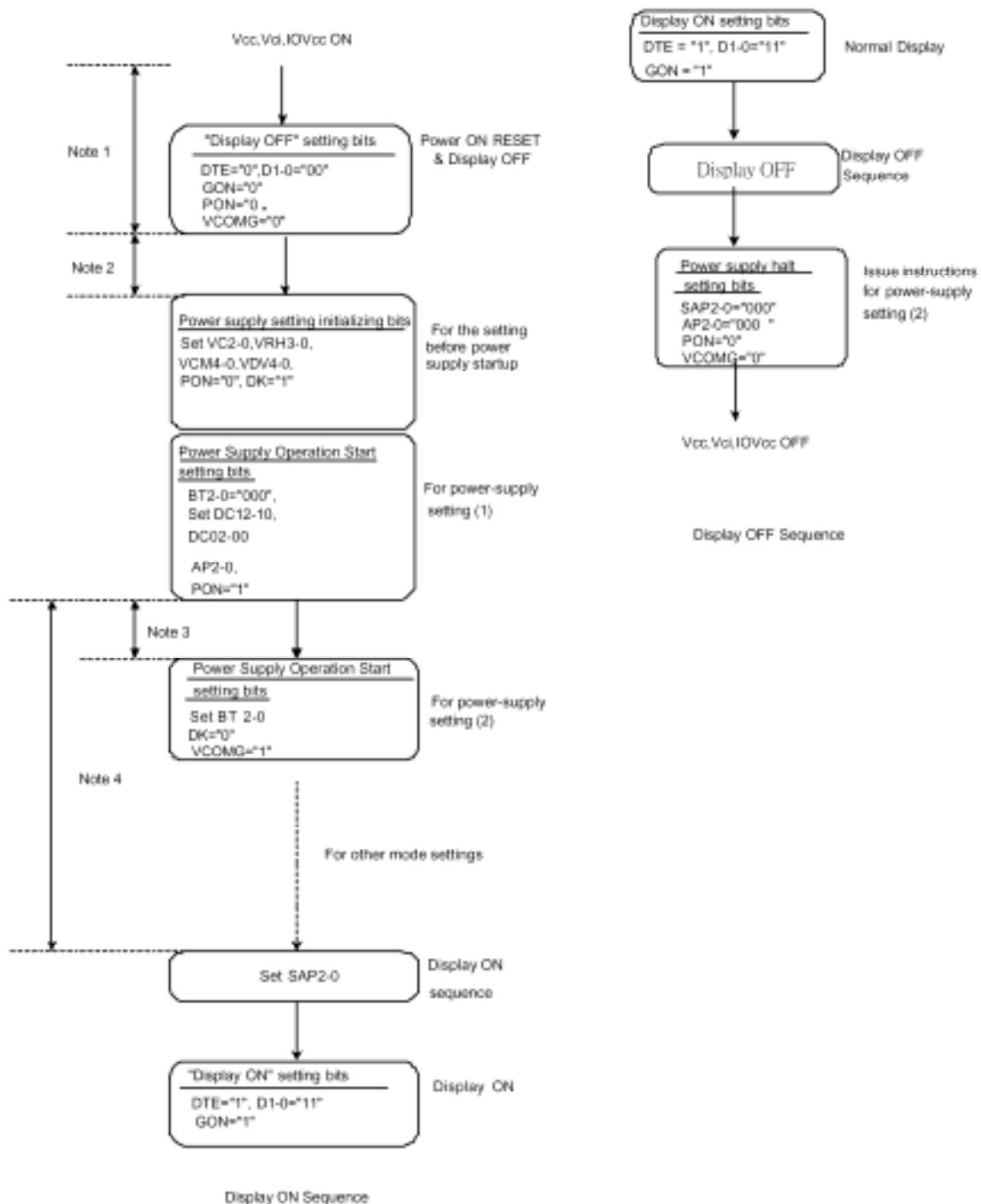

## 10 QUALITY AND RELIABILITY

### 10.1 TEST CONDITIONS

Tests should be conducted under the following conditions :

Ambient temperature :  $25 \pm 5^{\circ}\text{C}$   
Humidity :  $60 \pm 25\% \text{ RH}$ .

## 10.2 SAMPLING PLAN

Sampling method shall be in accordance with MIL-STD-105E , level II, normal single sampling plan .

## 10.3 ACCEPTABLE QUALITY LEVEL

A major defect is defined as one that could cause failure to or materially reduce the usability of the unit for its intended purpose. A minor defect is one that does not materially reduce the usability of the unit for its intended purpose or is an infringement from established standards and has no significant bearing on its effective use or operation.

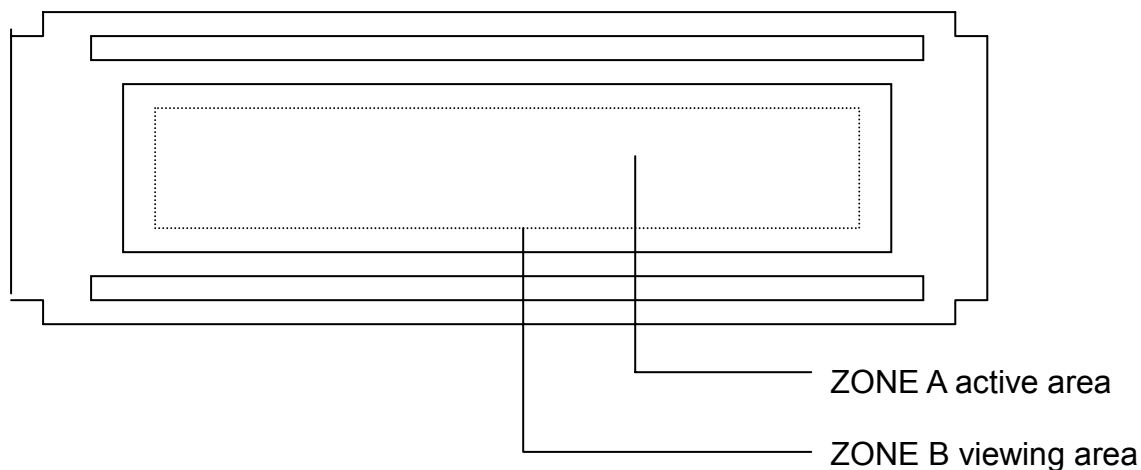

## 10.4 APPEARANCE

An appearance test should be conducted by human sight at approximately 30 cm distance from the LCD module under fluorescent light. The inspection area of LCD panel shall be within the range of following limits.

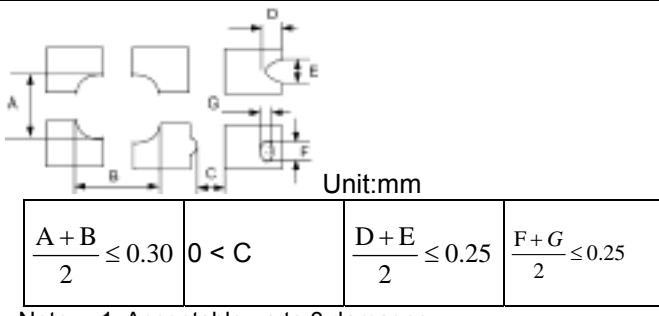

## 10.5 INSPECTION QUALITY CRITERIA

No.	Item	Criterion for defects	Defect type															
1	Non display	No non display is allowed	Major															
2	Irregular operation	No irregular operation is allowed	Major															
3	Short	No short are allowed	Major															
4	Open	Any segments or common patterns that don't activate are rejectable.	Major															
5	Black/White spot (I)	<table border="1" style="width: 100%; border-collapse: collapse;"> <thead> <tr> <th style="width: 50%;">Size D (mm)</th> <th style="width: 50%;">Acceptable number</th> </tr> </thead> <tbody> <tr> <td><math>D \leq 0.15</math></td> <td>Ignore</td> </tr> <tr> <td><math>0.15 &lt; D \leq 0.20</math></td> <td>3</td> </tr> <tr> <td><math>0.20 &lt; D \leq 0.30</math></td> <td>2</td> </tr> <tr> <td><math>0.30 &lt; D</math></td> <td>0</td> </tr> </tbody> </table>	Size D (mm)	Acceptable number	$D \leq 0.15$	Ignore	$0.15 < D \leq 0.20$	3	$0.20 < D \leq 0.30$	2	$0.30 < D$	0	Minor					
Size D (mm)	Acceptable number																	
$D \leq 0.15$	Ignore																	
$0.15 < D \leq 0.20$	3																	
$0.20 < D \leq 0.30$	2																	
$0.30 < D$	0																	
6	Black/White line (I)	<table border="1" style="width: 100%; border-collapse: collapse;"> <thead> <tr> <th style="width: 33%;">Length(mm)</th> <th style="width: 33%;">Width (mm)</th> <th style="width: 33%;">Acceptable number</th> </tr> </thead> <tbody> <tr> <td><math>10 &lt; L</math></td> <td><math>0.03 &lt; W \leq 0.04</math></td> <td>5</td> </tr> <tr> <td><math>5.0 &lt; L \leq 10</math></td> <td><math>0.04 &lt; W \leq 0.06</math></td> <td>3</td> </tr> <tr> <td><math>1.0 &lt; L \leq 5.0</math></td> <td><math>0.06 &lt; W \leq 0.07</math></td> <td>2</td> </tr> <tr> <td><math>L \leq 1.0</math></td> <td><math>0.07 &lt; W \leq 0.09</math></td> <td>1</td> </tr> </tbody> </table>	Length(mm)	Width (mm)	Acceptable number	$10 < L$	$0.03 < W \leq 0.04$	5	$5.0 < L \leq 10$	$0.04 < W \leq 0.06$	3	$1.0 < L \leq 5.0$	$0.06 < W \leq 0.07$	2	$L \leq 1.0$	$0.07 < W \leq 0.09$	1	Minor
Length(mm)	Width (mm)	Acceptable number																
$10 < L$	$0.03 < W \leq 0.04$	5																
$5.0 < L \leq 10$	$0.04 < W \leq 0.06$	3																
$1.0 < L \leq 5.0$	$0.06 < W \leq 0.07$	2																
$L \leq 1.0$	$0.07 < W \leq 0.09$	1																
7	Black/White sport (II)	<table border="1" style="width: 100%; border-collapse: collapse;"> <thead> <tr> <th style="width: 50%;">Size D (mm)</th> <th style="width: 50%;">Acceptable number</th> </tr> </thead> <tbody> <tr> <td><math>D \leq 0.30</math></td> <td>Ignore</td> </tr> <tr> <td><math>0.30 &lt; D \leq 0.50</math></td> <td>5</td> </tr> <tr> <td><math>0.50 &lt; D \leq 1.20</math></td> <td>3</td> </tr> <tr> <td><math>1.20 &lt; D</math></td> <td>0</td> </tr> </tbody> </table>	Size D (mm)	Acceptable number	$D \leq 0.30$	Ignore	$0.30 < D \leq 0.50$	5	$0.50 < D \leq 1.20$	3	$1.20 < D$	0	Minor					
Size D (mm)	Acceptable number																	
$D \leq 0.30$	Ignore																	
$0.30 < D \leq 0.50$	5																	
$0.50 < D \leq 1.20$	3																	
$1.20 < D$	0																	
8	Black/White line (II)	<table border="1" style="width: 100%; border-collapse: collapse;"> <thead> <tr> <th style="width: 33%;">Length (mm)</th> <th style="width: 33%;">Width (mm)</th> <th style="width: 33%;">Acceptable number</th> </tr> </thead> <tbody> <tr> <td><math>20 &lt; L</math></td> <td><math>0.05 &lt; W \leq 0.07</math></td> <td>5</td> </tr> <tr> <td><math>10 &lt; L \leq 20</math></td> <td><math>0.07 &lt; W \leq 0.09</math></td> <td>3</td> </tr> <tr> <td><math>5.0 &lt; L \leq 10</math></td> <td><math>0.09 &lt; W \leq 0.10</math></td> <td>2</td> </tr> <tr> <td><math>L \leq 5.0</math></td> <td><math>0.10 &lt; W \leq 0.15</math></td> <td>1</td> </tr> </tbody> </table>	Length (mm)	Width (mm)	Acceptable number	$20 < L$	$0.05 < W \leq 0.07$	5	$10 < L \leq 20$	$0.07 < W \leq 0.09$	3	$5.0 < L \leq 10$	$0.09 < W \leq 0.10$	2	$L \leq 5.0$	$0.10 < W \leq 0.15$	1	Minor
Length (mm)	Width (mm)	Acceptable number																
$20 < L$	$0.05 < W \leq 0.07$	5																
$10 < L \leq 20$	$0.07 < W \leq 0.09$	3																
$5.0 < L \leq 10$	$0.09 < W \leq 0.10$	2																
$L \leq 5.0$	$0.10 < W \leq 0.15$	1																
9	Back Light	1. No Lighting is rejectable 2. Flickering and abnormal lighting are rejectable	Major															

10	Display pattern	 <table border="1" data-bbox="486 392 1125 504"> <tr> <td><math>\frac{A+B}{2} \leq 0.30</math></td> <td><math>0 &lt; C</math></td> <td><math>\frac{D+E}{2} \leq 0.25</math></td> <td><math>\frac{F+G}{2} \leq 0.25</math></td> </tr> </table> <p>Note: 1. Acceptable up to 3 damages 2. NG if there're two or more pinholes per dot</p>	$\frac{A+B}{2} \leq 0.30$	$0 < C$	$\frac{D+E}{2} \leq 0.25$	$\frac{F+G}{2} \leq 0.25$	Minor																	
$\frac{A+B}{2} \leq 0.30$	$0 < C$	$\frac{D+E}{2} \leq 0.25$	$\frac{F+G}{2} \leq 0.25$																					
11	Blemish & Foreign matters  Size: $D = \frac{A+B}{2}$	<table border="1" data-bbox="454 593 1189 772"> <thead> <tr> <th>Size D (mm)</th> <th>Acceptable number</th> </tr> </thead> <tbody> <tr> <td><math>D \leq 0.15</math></td> <td>Ignore</td> </tr> <tr> <td><math>0.15 &lt; D \leq 0.20</math></td> <td>3</td> </tr> <tr> <td><math>0.20 &lt; D \leq 0.30</math></td> <td>2</td> </tr> <tr> <td><math>0.30 &lt; D</math></td> <td>0</td> </tr> </tbody> </table>	Size D (mm)	Acceptable number	$D \leq 0.15$	Ignore	$0.15 < D \leq 0.20$	3	$0.20 < D \leq 0.30$	2	$0.30 < D$	0	Minor											
Size D (mm)	Acceptable number																							
$D \leq 0.15$	Ignore																							
$0.15 < D \leq 0.20$	3																							
$0.20 < D \leq 0.30$	2																							
$0.30 < D$	0																							
12	Scratch on Polarizer  	<table border="1" data-bbox="454 828 1189 1064"> <thead> <tr> <th>Width (mm)</th> <th>Length (mm)</th> <th>Acceptable number</th> </tr> </thead> <tbody> <tr> <td><math>W \leq 0.03</math></td> <td>Ignore</td> <td>Ignore</td> </tr> <tr> <td><math>0.03 &lt; W \leq 0.05</math></td> <td><math>L \leq 2.0</math></td> <td>Ignore</td> </tr> <tr> <td></td> <td><math>L &gt; 2.0</math></td> <td>1</td> </tr> <tr> <td><math>0.05 &lt; W \leq 0.08</math></td> <td><math>L &gt; 1.0</math></td> <td>1</td> </tr> <tr> <td></td> <td><math>L \leq 1.0</math></td> <td>Ignore</td> </tr> <tr> <td><math>0.08 &lt; W</math></td> <td>Note (1)</td> <td>Note(1)</td> </tr> </tbody> </table> <p>Note(1) Regard as a blemish</p>	Width (mm)	Length (mm)	Acceptable number	$W \leq 0.03$	Ignore	Ignore	$0.03 < W \leq 0.05$	$L \leq 2.0$	Ignore		$L > 2.0$	1	$0.05 < W \leq 0.08$	$L > 1.0$	1		$L \leq 1.0$	Ignore	$0.08 < W$	Note (1)	Note(1)	Minor
Width (mm)	Length (mm)	Acceptable number																						
$W \leq 0.03$	Ignore	Ignore																						
$0.03 < W \leq 0.05$	$L \leq 2.0$	Ignore																						
	$L > 2.0$	1																						
$0.05 < W \leq 0.08$	$L > 1.0$	1																						
	$L \leq 1.0$	Ignore																						
$0.08 < W$	Note (1)	Note(1)																						
13	Bubble in polarizer	<table border="1" data-bbox="454 1153 1189 1332"> <thead> <tr> <th>Size D (mm)</th> <th>Acceptable number</th> </tr> </thead> <tbody> <tr> <td><math>D \leq 0.20</math></td> <td>Ignore</td> </tr> <tr> <td><math>0.20 &lt; D \leq 0.50</math></td> <td>3</td> </tr> <tr> <td><math>0.50 &lt; D \leq 0.80</math></td> <td>2</td> </tr> <tr> <td><math>0.80 &lt; D</math></td> <td>0</td> </tr> </tbody> </table>	Size D (mm)	Acceptable number	$D \leq 0.20$	Ignore	$0.20 < D \leq 0.50$	3	$0.50 < D \leq 0.80$	2	$0.80 < D$	0	Minor											
Size D (mm)	Acceptable number																							
$D \leq 0.20$	Ignore																							
$0.20 < D \leq 0.50$	3																							
$0.50 < D \leq 0.80$	2																							
$0.80 < D$	0																							
14	Stains on LCD panel surface	Stains that cannot be removed even when wiped lightly with a soft cloth or similar cleaning too are rejectable.	Minor																					
15	Rust in Bezel	Rust which is visible in the bezel is rejectable.	Minor																					
16	Defect of land surface contact (poor soldering)	Evident crevices which is visible are rejectable.	Minor																					
17	Parts mounting	<ol style="list-style-type: none"> <li>1. Failure to mount parts</li> <li>2. Parts not in the specifications are mounted</li> <li>3. Polarity, for example, is reversed</li> </ol>	Major Major Major																					
18	Parts alignment	<ol style="list-style-type: none"> <li>1. LSI, IC lead width is more than 50% beyond pad outline.</li> <li>2. Chip component is off center and more than 50% of the leads is off the pad outline.</li> </ol>	Minor  Minor																					

19	Conductive foreign matter (Solder ball, Solder chips)	1. $0.45 < \varphi$ , $N \geq 1$ 2. $0.30 < \varphi \leq 0.45$ , $N \geq 1$ $\varphi$ : Average diameter of solder ball (unit: mm) 3. $0.50 < L$ , $N \geq 1$ L: Average length of solder chip (unit: mm)	Major Minor  Minor
20	Faulty PCB correction	1. Due to PCB copper foil pattern burnout, the pattern is connected, using a jumper wire for repair; 2 or more places are corrected per PCB. 2. Short circuited part is cut, and no resist coating has been performed.	Minor  Minor

## 10.6 RELIABILITY

Test Item	Test Conditions	Note
High Temperature Operation	70±3°C , t=96 hrs	
Low Temperature Operation	-20±3°C , t=96 hrs	
High Temperature Storage	80±3°C , t=96 hrs	1,2
Low Temperature Storage	-30±3°C , t=96 hrs	1,2
Humidity Test	40°C , Humidity 90%, 96 hrs	1,2
Thermal Shock Test	-30°C ~ 25°C ~ 80°C 30 min. 5 min. 30 min. ( 1 cycle ) Total 5 cycle	1,2
Vibration Test (Packing)	Sweep frequency : 10~55~10 Hz/1min Amplitude : 0.75mm Test direction : X.Y.Z/3 axis Duration : 30min/each axis	2
Static Electricity	150pF 330 ohm ±8kV, 10times air discharge 150pF 330 ohm ±4kV, 10times contact discharge	

Note 1 : Condensation of water is not permitted on the module.

Note 2 : The module should be inspected after 1 hour storage in normal conditions

(15-35°C , 45-65%RH).

Definitions of life end point :

- Current drain should be smaller than the specific value.
- Function of the module should be maintained.
- Appearance and display quality should not have degraded noticeably.
- Contrast ratio should be greater than 50% of the initial value.

Box Drop Test:

The module test on packing:

Falling body Height and Weight:

Totally Weight	Falling body Height
0 ~ 9 Kg	92 cm
9 ~ 25 Kg	76 cm
25 ~ 45 Kg	53 cm
45 ~ 68 Kg	46 cm
Over68 Kg	41 cm

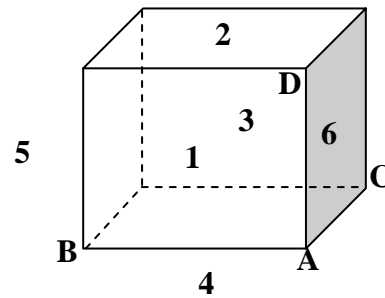

The dropping test in turns :

1. Conner A
2. Edges of the planes : 1-4 , 1-6 , 4-6
3. Planes : 1 , 2 , 3 , 4 , 5 , 6

## 11 USE PRECAUTIONS

### 11.1 Handling precautions

- 1) The polarizing plate may break easily so be careful when handling it. Do not touch, press or rub it with a hard-material tool like tweezers.
- 2) Do not touch the polarizing plate surface with bare hands so as not to make it dirty. If the surface or other related part of the polarizing plate is dirty, soak a soft cotton cloth or chamois leather in benzine and wipe off with it. Do not use chemical liquids such as acetone, toluene and isopropyl alcohol. Failure to do so may bring chemical reaction phenomena and deteriorations.
- 3) Remove any spit or water immediately. If it is left for hours, the suffered part may deform or decolorize.
- 4) If the LCD element breaks and any LC stuff leaks, do not suck or lick it. Also if LC stuff is stuck on your skin or clothing, wash thoroughly with soap and water immediately.

### 11.2 Installing precautions

- 1) The PCB has many ICs that may be damaged easily by static electricity. To prevent breaking by static electricity from the human body and clothing, earth the human body properly using the high resistance and discharge static electricity during the operation. In this case, however, the resistance value should be approx.  $1M\Omega$  and the resistance should be placed near the human body rather than the ground surface. When the indoor space is dry, static electricity may occur easily so be careful. We recommend the indoor space should be kept with humidity of 60% or more. When a soldering iron or other similar tool is used for assembly, be sure to earth it.
- 2) When installing the module and ICs, do not bend or twist them. Failure to do so may crack LC element and cause circuit failure.
- 3) To protect LC element, especially polarizing plate, use a transparent protective plate (e.g., acrylic plate, glass etc) for the product case.
- 4) Do not use an adhesive like a both-side adhesive tape to make LCD surface (polarizing plate) and product case stick together. Failure to do so may cause the polarizing plate to peel off.

### 11.3 Storage precautions

- 1) Avoid a high temperature and humidity area. Keep the temperature between

0°C and 35°C and also the humidity under 60%.

- 2) Choose the dark spaces where the product is not exposed to direct sunlight or fluorescent light.
- 3) Store the products as they are put in the boxes provided from us or in the same conditions as we recommend.

## 11.4 Operating precautions

- 1) Do not boost the applied drive voltage abnormally. Failure to do so may break ICs. When applying power voltage, check the electrical features beforehand and be careful. Always turn off the power to the LC module controller before removing or inserting the LC module input connector. If the input connector is removed or inserted while the power is turned on, the LC module internal circuit may break.
- 2) The display response may be late if the operating temperature is under the normal standard, and the display may be out of order if it is above the normal standard. But this is not a failure; this will be restored if it is within the normal standard.
- 3) The LCD contrast varies depending on the visual angle, ambient temperature, power voltage etc. Obtain the optimum contrast by adjusting the LC drive voltage.
- 4) When carrying out the test, do not take the module out of the low-temperature space suddenly. Failure to do so will cause the module condensing, leading to malfunctions.
- 5) Make certain that each signal noise level is within the standard (L level: 0.2V<sub>dd</sub> or less and H level: 0.8V<sub>dd</sub> or more) even if the module has functioned properly. If it is beyond the standard, the module may often malfunction. In addition, always connect the module when making noise level measurements.
- 6) The CMOS ICs are incorporated in the module and the pull-up and pull-down function is not adopted for the input so avoid putting the input signal open while the power is ON.
- 7) The characteristic of the semiconductor element changes when it is exposed to light emissions, therefore ICs on the LCD may malfunction if they receive light emissions. To prevent these malfunctions, design and assemble ICs so that they are shielded from light emissions.
- 8) Crosstalk occurs because of characteristics of the LCD. In general, crosstalk

occurs when the regularized display is maintained. Also, crosstalk is affected by the LC drive voltage. Design the contents of the display, considering crosstalk.

### 11.5Other

- 1) Do not disassemble or take the LC module into pieces. The LC modules once disassembled or taken into pieces are not the guarantee articles.
- 2) The residual image may exist if the same display pattern is shown for hours. This residual image, however, disappears when another display pattern is shown or the drive is interrupted and left for a while. But this is not a problem on reliability.

# 12 Mechanic Drawing

