



A Brighter Solution

AMP DISPLAY INC.

SPECIFICATIONS

12.1 Color TFT MODULE w/ Touch

CUSTOMER:	
CUSTOMER PART NO.	
AMP DISPLAY PART NO.	AM-1024768GTMQW-T00H
APPROVED BY:	
DATE:	

APPROVED FOR SPECIFICATIONS

APPROVED FOR SPECIFICATION AND PROTOTYPES

AMP DISPLAY INC

9856 SIXTH STREET RANCHO CUCAMONGA CA 91730
TEL: 909-980-13410 FAX: 909-980-1419
WWW.AMPDISPLAY.COM

AMP DISPLAY NUMBERING SYSTEM

<u>A</u>	<u>C</u>	<u>20</u>	<u>2</u>	<u>A</u>	<u>Y</u>	<u>I</u>	<u>L</u>	<u>Y</u>	<u>70</u>	<u>H</u>
1	2	3	4	5	6	7	8	9	10	11

1-	Company:	A [AMPire/AMP display]
2-	LCM type	G :Graphic C :Character T : Tab M : TFT D : Custom Design]
3-	Row Dots Number	128, 240, 320] Character per line [08, 16, 20,24,40]
4-	Column dots number	32, 64, 128, 240
		Lines: [1, 2, 4,
5-	LCD Module serial Number	[A-Z]
6-	LCD Type :	N = TN Type LCD H = HTN Type LCD Y = STN Yellow-Green Type LCD G = STN Gray Type LCD S = STN Negative Type LCD F = FSTN Type LCD P = FSTN White Type LCD Paper white W = FSTN White Type LCD Paper white, No reverse T = TFT LCD O = OLED
7-	Polarizer & Viewing angle type	A,B [Reflective A:6H, B: 12H]
		I,J,K,L [Transflective : I=6H, J=9H, K=12H, L=3H]
		Q,X [Transflective; Q=10:30, X=4:30H]
		M,N,O,P,R [Transmissive: M=6H, N= 12H ,O =9H, P =3H, R =4:30]
		T,U,V,W, Y [Negative type: T=6H,U=12H,V=3H,W=4:30,Y=9H]
		S =Single blue/Area color F = Full Color
8-	Backlight Type	None = Without backlight
		L =5V LED, 0 =12V LED, P =24V LED, Q =Edge=Lit LED, E =EL, C=CCFL
9-	Backlight Color	None Without backlight A =Amber, B = Blue, G = Green, R =Red, Y =Yellow-green, W =White D = Double Color (Y, G&R) , T =RGB, , P = Lamp
10-	Version Code	00~ZZ, D0 ~ D9 Version Code/Double Display
11-	LCM Temp	Normal Temperature H = Extgended Temperature

RECORD OF REVISION

Revision Date	Page	Contents	Editor
2010/10/21	-	New Release	Patrick

1. FEATURES

AM-1024768G model is a 12.1" TFT-LCD module with a white LED Backlight Unit and a 20-pin 1ch-LVDS interface. This module supports 1024 x 768 XGA mode and displays 262k\16.2M colors. The converter for the Backlight Unit is built in.

- Wide Viewing angle
- High contrast ratio
- Fast response time
- XGA (1024 x 768 pixels) resolution
- Wide operating temperature
- DE (Data Enable) mode
- LVDS (Low Voltage Differential Signaling) interface
- Reversible-scan direction
- RoHS Compliance
- Lamp Replaceable
- Touch Panel

APPLICATIONS

- TFT LCD Monitor
- Industrial Application
- Amusement
- Vehicle

2. PHYSICAL SPECIFICATIONS

Item	Specifications	Unit	Note
Active area	245.76 (H) ×184.32 (V)	mm	(1)
Driver Element	a-si TFT active matrix	-	-
Pixel Number	1024 x R.G.B x 768	pixel	-
Pixel Pitch	0.240(H) x 0.240(V)	mm	-
Pixel Arrangement	RGB vertical stripe	-	-
Display Colors	262K/16.2M	color	-
Transmissive Mode	Normally white	-	-
Surface Treatment	Hard coating (3H), Glare	-	-
Module Power Consumption	13.6	W	Typ.
Weight	700(Typ.)		

Note (1) Please refer to the attached drawings for more information of front and back outline dimensions.

(2) Connector mounting position

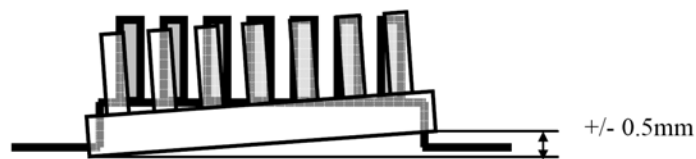

3. ABSOLUTE MAX. RATINGS

The followings are maximum values which, if exceed, may cause faulty operation or damage to the unit.

Item	Symbol	Values		UNIT	Note
		Min.	Max.		
Operating Ambient Temperature	T _{OP}	-30	+80	°C	
Storage Temperature	T _{ST}	-40	+85	°C	
Power Supply Voltage	V _{CC}	-0.3	7	V	(1)
Converter Voltage	V _i	-0.3	18	V	(1) · (2)
Enable Voltage	EN	-	5.5	V	
Backlight Adjust	ADJ	-	5.5	V	

Note (1) Permanent damage to the device may occur if maximum values are exceeded. Function operation should be restricted to the conditions described under Normal Operating Conditions.

Note (2) Specified values are for lamp (Refer to 3.2 for further information).

Relative Humidity (%RH)

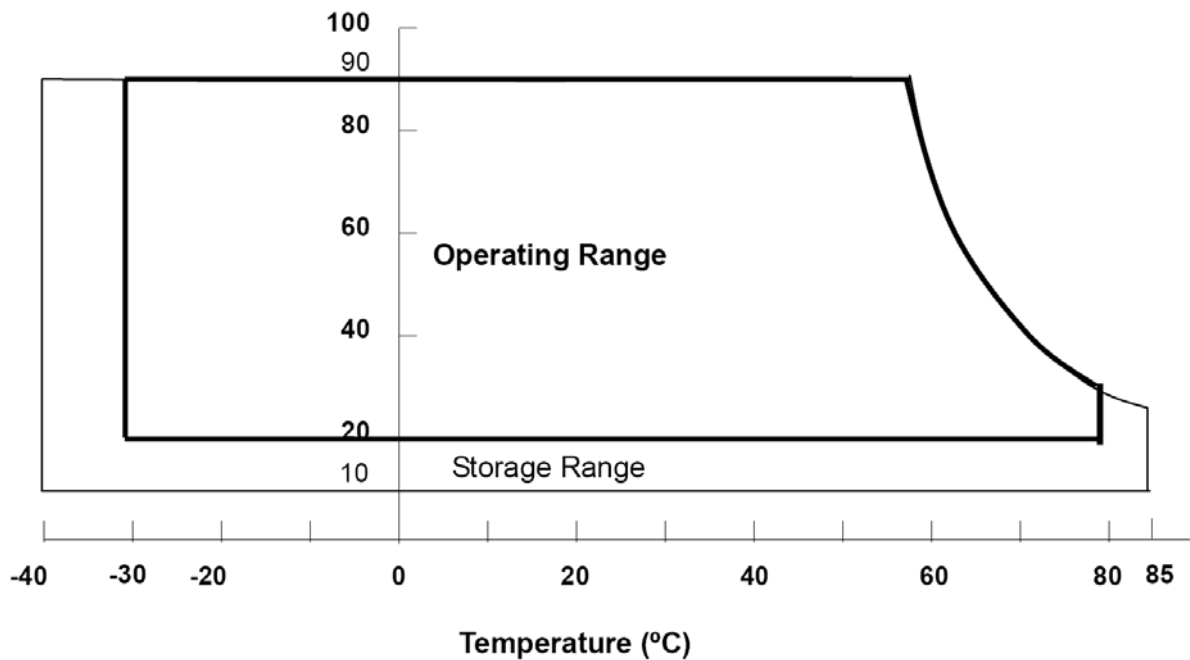

4. ELECTRICAL CHARACTERISTICS

4.1 TFT LCD Module

Parameter	Symbol	Value			Unit	Note
		Min.	Typ.	Max.		
Power Supply Voltage	V_{CC}	3.0	3.3	3.6	V	(1) at $V_{CC}=3.3V$
		4.75	5.0	5.25	V	(1) at $V_{CC}=5.0V$
Rush Current	I_{RUSH}	-	-	4	A	(2)
Power Supply Current	White	-	410	-	mA	(3)a, at $V_{CC}=3.3V$
		-	320	-	mA	(3)a, at $V_{CC}=5.0V$
	Black	-	540	-	mA	(3)b, at $V_{CC}=3.3V$
		-	400	-	mA	(3)b, at $V_{CC}=5.0V$
Power Consumption	P_L	-	2.0	-	W	
LVDS differential input voltage	$ VID $	100	-	600	mV	-
LVDS common input voltage	V_{ICM}	0.7	-	1.6	V	-

Note (1) The assembly should be always operated within above ranges.

Note (2) Measurement Conditions:

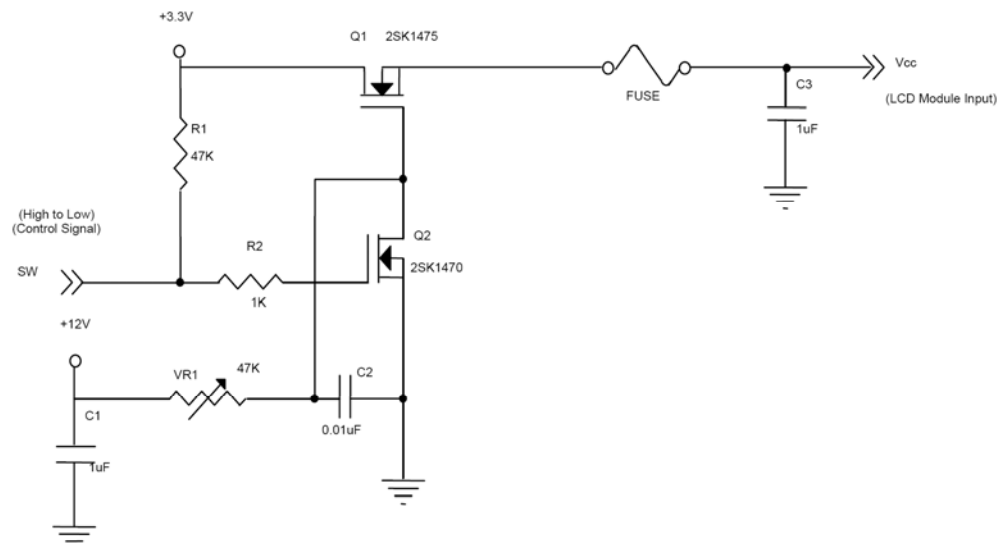

Vcc rising time is 470 μ s

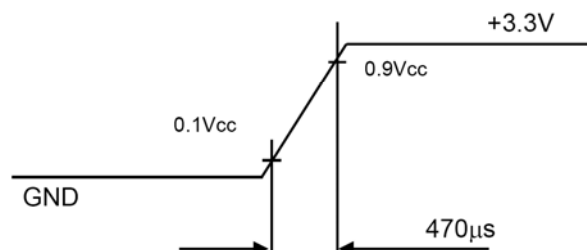

Note (3) The specified power supply current is under the conditions at $V_{cc} = 3.3V$ or $5V$, $T_a = 25 \pm 2 \text{ }^\circ\text{C}$, $f_v = 60 \text{ Hz}$, whereas a power dissipation check pattern below is displayed.

a. White Pattern



Active Area

b. Black Pattern



Active Area

4.2 Backlight Unit

$T_a = 25 \pm 2 \text{ }^\circ\text{C}$

Parameter	Symbol	Value			Unit	Note	
		Min.	Typ.	Max.			
Converter Power Supply Voltage	V_i	10.8	12.0	13.2	V		
Converter Power Supply Current	I_i	-	1.0	-	A	@ $V_i = 12V$ (Duty 100%)	
LED Power Consumption	P_{LED}	-	12	-	W	@ $V_i = 12V$ (Duty 100%)	
EN Control Level	Backlight on	-	2.0	3.3	5.0	V	
	Backlight off	-	0	---	0.8	V	
PWM Control Level	PWM High Level	-	2.0	3.3	5.0	V	
	PWM Low Level	-	0	-	0.15	V	
PWM Control Duty Ratio	-	20	-	100	%		
PWM Control Frequency	f_{PWM}	190	200	210	Hz		
LED Life Time	L_L	50,000	-	-	Hrs	(2)	

Note (1) LED current is measured by utilizing a high frequency current meter as shown below:

Note (2) The lifetime of LED is defined as the time when it continues to operate under the conditions at

$T_a = 25 \pm 2 \text{ }^\circ\text{C}$ and Duty 100% until the brightness becomes $\leq 50\%$ of its original value.

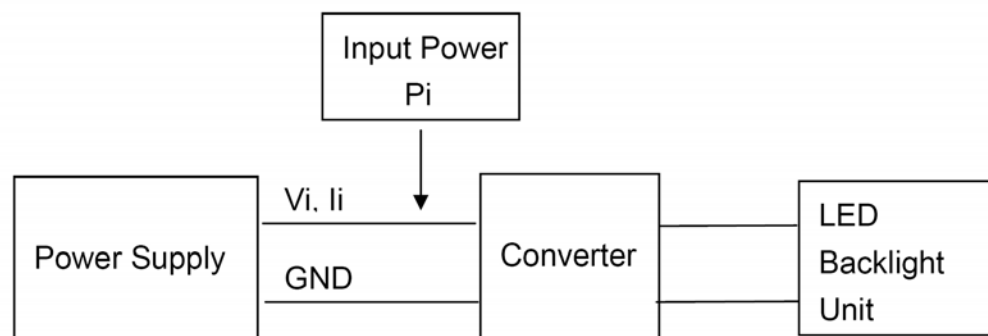

4-3 Touch Panel Electrical Specification

Parameter	Condition	Standard Value
Terminal Resistance	X Axis	340 ~ 1090 Ω
	Y Axis	120 ~ 600 Ω
Insulating Resistance	DC 25 V	More than 10MΩ
Linearity	--	±1.5 %
Pen writing Durability	Note A	100,000 times(min)
Input life by finger	Note B	1,000,000 times (min)

Note A .

Writing length 35 mm.

Writing speed: 300mm/sec.

Shape of pen end : R0.8

Load : 250 g

Note B

By Silicon rubber tapping at same point

Shape of rubber end : R8

Load : 200g

Frequency : 5 Hz

Interface

No.	Symbol	Function
1	XR	Touch Panel Right Signal
2	YD	Touch Panel Bottom Signal
3	XL	Touch Panel Left Signal
4	YU	Touch Panel Top Signal

5. OPTICAL SPECIFICATION

5.1 Test Conditions

Item	Symbol	Value	Unit
Ambient Temperature	Ta	25±2	°C
Ambient Humidity	Ha	50±10	%RH
Supply Voltage	V _{CC}	3.3	V
Input Signal	According to typical value in "3. ELECTRICAL CHARACTERISTICS"		
Converter Voltage	V _{in}	12	V
Converter Duty		100%	

5.2 Optical Specifications

The relative measurement methods of optical characteristics are shown in 7.2. The following items should be measured under the test conditions described in 7.1 and stable environment shown in Note (5).

Item	Symbol	Condition	Min.	Typ.	Max.	Unit	Note				
Color Chromaticity	Red	R _x	Typ - 0.03	0.625	Typ + 0.03	-	(1), (5)				
		R _y		0.358		-					
	Green	G _x		0.324		-					
		G _y		0.604		-					
	Blue	B _x		0.144		-					
		B _y		0.088		-					
	White	W _x		0.313		-					
		W _y		0.329		-					
	Center Luminance of White	L _c				380		500	-	-	(4), (5)
	Contrast Ratio	CR				500		700	-	-	(2), (5)
Contrast Ratio in daylight		Sun lamp	40	60	-	-	(7)				
Response Time	T _R	θ _x =0°, θ _y =0°	-	5	10	ms	(3)				
	T _F		-	11	16	ms					
White Variation	δW	θ _x =0°, θ _y =0°	-	1.25	1.4	-	(5), (6)				
Viewing Angle	Horizontal	θ _{x+}	CR≥10	70	80	-	Deg.	(1), (5)			
		θ _{x-}		70	80	-					
	Vertical	θ _{y+}		70	80	-					
		θ _{y-}		70	80	-					

Note (1) Definition of Viewing Angle (θ_x, θ_y):

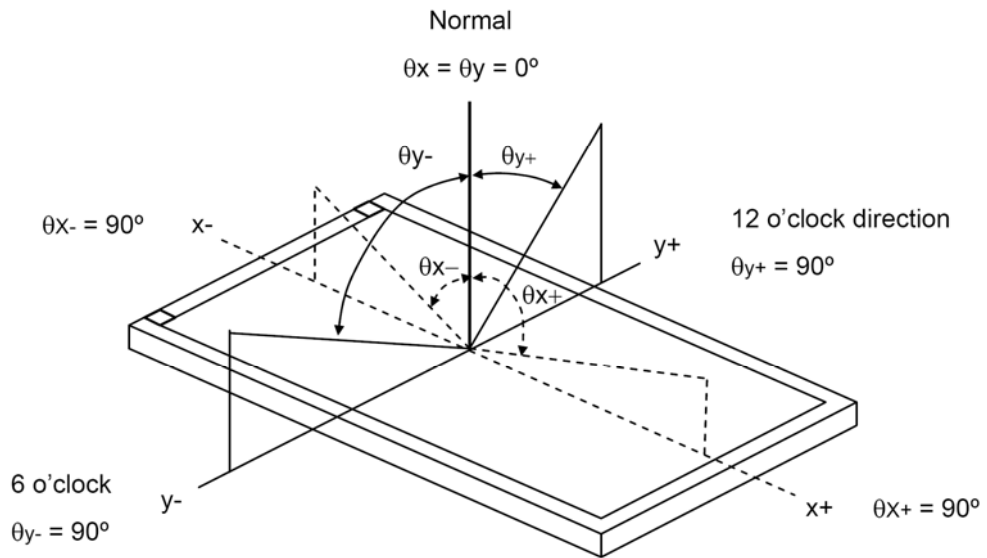

Note (2) Definition of Contrast Ratio (CR):

The contrast ratio can be calculated by the following expression.

$$\text{Contrast Ratio (CR)} = L_{63} / L_0$$

L63: Luminance of gray level 63

L 0: Luminance of gray level 0

$$\text{CR} = \text{CR} (5)$$

CR (X) is corresponding to the Contrast Ratio of the point X at Figure in Note (6).

Note (3) Definition of Response Time (T_R, T_F) and measurement method:

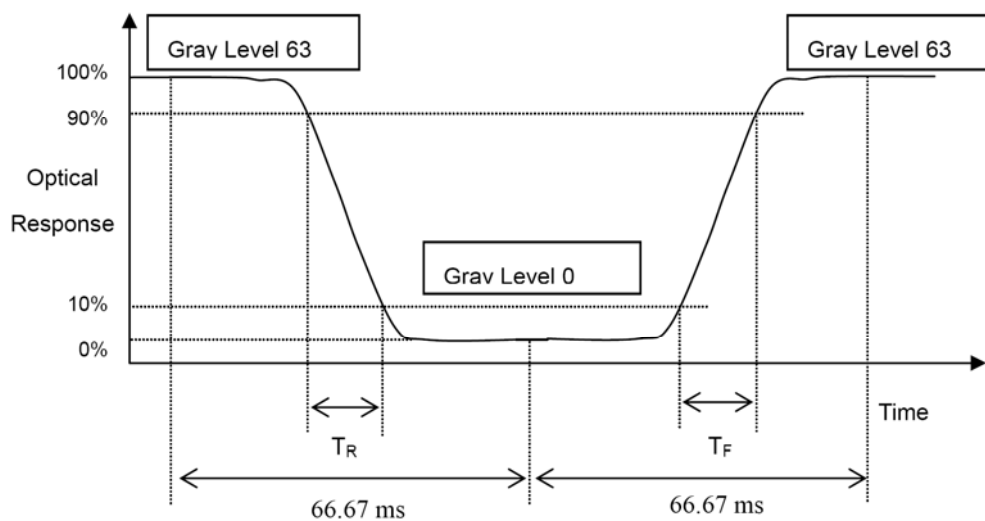

Note (4) Definition of Luminance of White (L_c):

Measure the luminance of gray level 63 at center point

$$L_c = L(5)$$

$L(x)$ is corresponding to the luminance of the point X at Figure in Note (6).

Note (5) Measurement Setup:

The LCD module should be stabilized at given temperature for 20 minutes to avoid abrupt temperature change during measuring. In order to stabilize the luminance, the measurement should be executed after lighting Backlight for 20 minutes in a windless room.

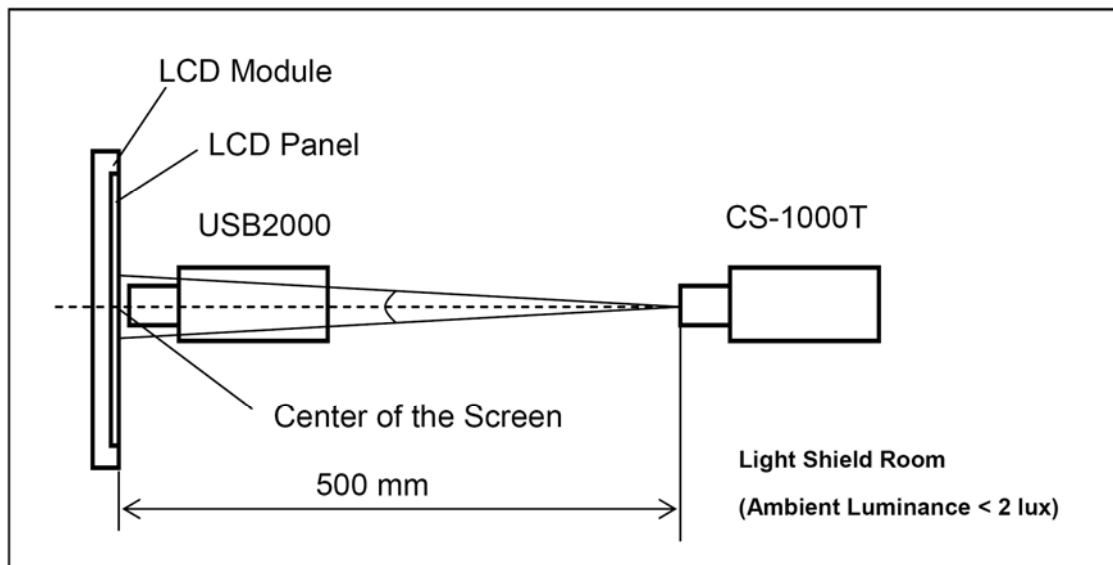

Note (6) Definition of White Variation (δW):

Measure the luminance of gray level 63 at 5 points

$$\delta W = \frac{\text{Maximum [L (1), L (2), L (3), L (4), L (5)]}}{\text{Minimum [L (1), L (2), L (3), L (4), L (5)]}}$$

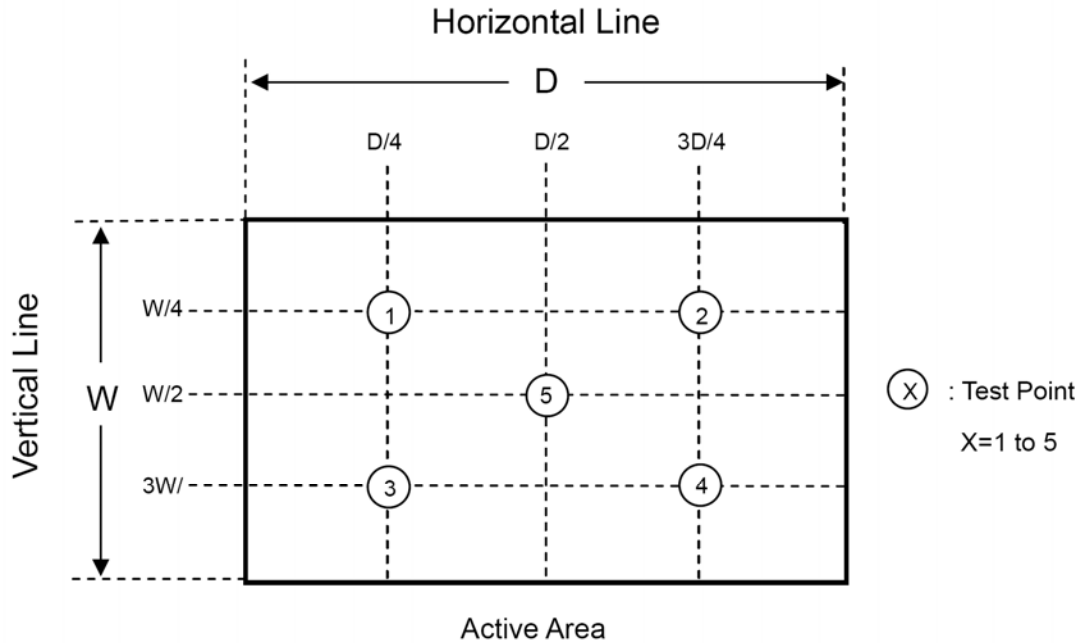

Note (7) Contrast Ratio in daylight:

Measuring carried out at backlight unit on

Sun lamp: 10000 Lux

Contrast Ratio in daylight = Luminance of white screen / Luminance of black screen

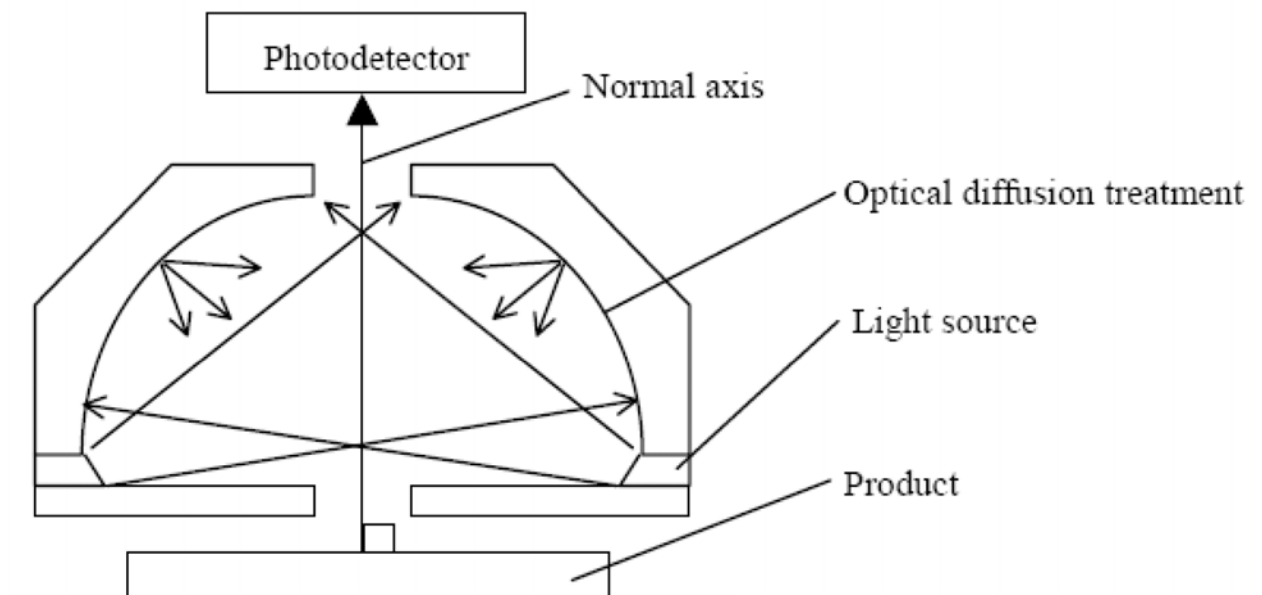

6. INTERFACE

6.1 TFT LCD Module

Pin	Name	Description	Remark
1	RX3+	Differential Data Input, CH3 (Positive)	
2	RX3-	Differential Data Input, CH3 (Negative)	
3	NC	NC	
4	SEL68	LVDS 6/8 bit select function control, Low or NC → 6 bit Input Mode High → 8bit Input Mode	Note (3)
5	GND	Ground	
6	RXC+	Differential Clock Input (Positive)	
7	RXC-	Differential Clock Input (Negative)	
8	GND	Ground	
9	RX2+	Differential Data Input , CH2 (Positive)	
10	RX2-	Differential Data Input , CH2 (Negative)	
11	GND	Ground	
12	RX1+	Differential Data Input , CH1 (Positive)	
13	RX1-	Differential Data Input, CH1 (Negative)	
14	GND	Ground	
15	RX0+	Differential Data Input, CH0 (Positive)	
16	RX0-	Differential Data Input, CH0 (Negative)	
17	reLR	Horizontal Reverse Scan Control, Low or NC → Normal Mode. High → Horizontal Reverse Scan	Note (3)
18	reUD	Vertical Reverse Scan Control, Low or NC → Normal Mode, High → Vertical Reverse Scan	Note (3)
19	VCC	Power supply	
20	VCC	Power supply	

Note (1) Connector Part No.: STARCONN 076B20-0048RA-G4 or JAE FI-SEB20P-HFE or equivalent.

Note (2) User's connector Part No.: JAE FI-SE20ME or equivalent.

Note (3) "Low" stands for 0V. "High" stands for 3.3V. "NC" stands for "No Connected".

6.2 Backlight Unit (Converter connector pin)

Pin	Symbol	Description	Remark
1	V_i	Converter input voltage	12V
2	V_i	Converter input voltage	12V
3	V_i	Converter input voltage	12V
4	V_i	Converter input voltage	12V
5	V_{GND}	Converter ground	Ground
6	V_{GND}	Converter ground	Ground
7	V_{GND}	Converter ground	Ground
8	V_{GND}	Converter ground	Ground
9	EN	Enable pin	3.3V
10	ADJ	Backlight Adjust	PWM Dimming (190-210Hz, Hi: 3.3V _{DC} , Lo: 0V _{DC})

Note (1) Connector Part No.: 91208-01001-H01 (ACES) or equivalent.

Note (2) User's connector Part No.: 91209-01011 (ACES) or equivalent

6.3 Color Data Input Assignment

The brightness of each primary color (red, green and blue) is based on the 6-bit gray scale data input for the color. The higher the binary input, the brighter the color. The table below provides the assignment of color versus data input.

Color		Data Signal																	
		Red						Green						Blue					
		R5	R4	R3	R2	R1	R0	G5	G4	G3	G2	G1	G0	B5	B4	B3	B2	B1	B0
Basic Colors	Black	0	0	0	0	0	0	0	0	0	0	0	0	0	0	0	0	0	0
	Red	1	1	1	1	1	1	0	0	0	0	0	0	0	0	0	0	0	0
	Green	0	0	0	0	0	0	1	1	1	1	1	1	0	0	0	0	0	0
	Blue	0	0	0	0	0	0	0	0	0	0	0	0	1	1	1	1	1	1
	Cyan	0	0	0	0	0	0	1	1	1	1	1	1	1	1	1	1	1	1
	Magenta	1	1	1	1	1	1	0	0	0	0	0	0	1	1	1	1	1	1
	Yellow	1	1	1	1	1	1	1	1	1	1	1	1	0	0	0	0	0	0
	White	1	1	1	1	1	1	1	1	1	1	1	1	1	1	1	1	1	1
Gray Scale Of Red	Red(0)/Dark	0	0	0	0	0	0	0	0	0	0	0	0	0	0	0	0	0	0
	Red(1)	0	0	0	0	0	1	0	0	0	0	0	0	0	0	0	0	0	0
	Red(2)	0	0	0	0	1	0	0	0	0	0	0	0	0	0	0	0	0	0
	:	:	:	:	:	:	:	:	:	:	:	:	:	:	:	:	:	:	:
	:	:	:	:	:	:	:	:	:	:	:	:	:	:	:	:	:	:	:
	:	:	:	:	:	:	:	:	:	:	:	:	:	:	:	:	:	:	:
	Red(61)	1	1	1	1	0	1	0	0	0	0	0	0	0	0	0	0	0	0
	Red(62)	1	1	1	1	1	0	0	0	0	0	0	0	0	0	0	0	0	0
Red(63)	1	1	1	1	1	1	0	0	0	0	0	0	0	0	0	0	0	0	
Gray Scale Of Green	Green(0)/Dark	0	0	0	0	0	0	0	0	0	0	0	0	0	0	0	0	0	0
	Green(1)	0	0	0	0	0	0	0	0	0	0	1	0	0	0	0	0	0	0
	Green(2)	0	0	0	0	0	0	0	0	0	1	0	0	0	0	0	0	0	0
	:	:	:	:	:	:	:	:	:	:	:	:	:	:	:	:	:	:	:
	:	:	:	:	:	:	:	:	:	:	:	:	:	:	:	:	:	:	:
	:	:	:	:	:	:	:	:	:	:	:	:	:	:	:	:	:	:	:
	Green(61)	0	0	0	0	0	0	1	1	1	1	0	1	0	0	0	0	0	0
	Green(62)	0	0	0	0	0	0	1	1	1	1	1	0	0	0	0	0	0	0
Green(63)	0	0	0	0	0	0	1	1	1	1	1	1	0	0	0	0	0	0	
Gray Scale Of Blue	Blue(0)/Dark	0	0	0	0	0	0	0	0	0	0	0	0	0	0	0	0	0	0
	Blue(1)	0	0	0	0	0	0	0	0	0	0	0	0	0	0	0	0	0	1
	Blue(2)	0	0	0	0	0	0	0	0	0	0	0	0	0	0	0	0	1	0
	:	:	:	:	:	:	:	:	:	:	:	:	:	:	:	:	:	:	:
	:	:	:	:	:	:	:	:	:	:	:	:	:	:	:	:	:	:	:
	:	:	:	:	:	:	:	:	:	:	:	:	:	:	:	:	:	:	:
	Blue(61)	0	0	0	0	0	0	0	0	0	0	0	0	1	1	1	1	0	1
	Blue(62)	0	0	0	0	0	0	0	0	0	0	0	0	1	1	1	1	1	0
Blue(63)	0	0	0	0	0	0	0	0	0	0	0	0	1	1	1	1	1	1	

Note (1) 0: Low Level Voltage, 1: High Level Voltage

The brightness of each primary color (red, green and blue) is based on the 8-bit gray scale data input for the color. The higher the binary input, the brighter the color. The table below provides the assignment of color versus data input.

Color		Data Signal																							
		Red								Green								Blue							
		R7	R6	R5	R4	R3	R2	R1	R0	G7	G6	G5	G4	G3	G2	G1	G0	B7	B6	B5	B4	B3	B2	B1	B0
Basic Colors	Black	0	0	0	0	0	0	0	0	0	0	0	0	0	0	0	0	0	0	0	0	0	0	0	
	Red	1	1	1	1	1	1	1	1	0	0	0	0	0	0	0	0	0	0	0	0	0	0	0	
	Green	0	0	0	0	0	0	0	0	1	1	1	1	1	1	1	1	0	0	0	0	0	0	0	
	Blue	0	0	0	0	0	0	0	0	0	0	0	0	0	0	0	0	1	1	1	1	1	1	1	
	Cyan	0	0	0	0	0	0	0	0	1	1	1	1	1	1	1	1	1	1	1	1	1	1	1	
	Magenta	1	1	1	1	1	1	1	1	0	0	0	0	0	0	0	0	1	1	1	1	1	1	1	
	Yellow	1	1	1	1	1	1	1	1	1	1	1	1	1	1	1	1	0	0	0	0	0	0	0	
	White	1	1	1	1	1	1	1	1	1	1	1	1	1	1	1	1	1	1	1	1	1	1	1	
Gray Scale Of Red	Red(0) / Dark	0	0	0	0	0	0	0	0	0	0	0	0	0	0	0	0	0	0	0	0	0	0		
	Red(1)	0	0	0	0	0	0	0	1	0	0	0	0	0	0	0	0	0	0	0	0	0	0		
	Red(2)	0	0	0	0	0	0	1	0	0	0	0	0	0	0	0	0	0	0	0	0	0	0		
	⋮	⋮	⋮	⋮	⋮	⋮	⋮	⋮	⋮	⋮	⋮	⋮	⋮	⋮	⋮	⋮	⋮	⋮	⋮	⋮	⋮	⋮	⋮		
	⋮	⋮	⋮	⋮	⋮	⋮	⋮	⋮	⋮	⋮	⋮	⋮	⋮	⋮	⋮	⋮	⋮	⋮	⋮	⋮	⋮	⋮	⋮		
	Red(253)	1	1	1	1	1	1	0	1	0	0	0	0	0	0	0	0	0	0	0	0	0	0		
	Red(254)	1	1	1	1	1	1	1	0	0	0	0	0	0	0	0	0	0	0	0	0	0	0		
	Red(255)	1	1	1	1	1	1	1	1	0	0	0	0	0	0	0	0	0	0	0	0	0	0		
Gray Scale Of Green	Green(0) / Dark	0	0	0	0	0	0	0	0	0	0	0	0	0	0	0	0	0	0	0	0	0	0		
	Green(1)	0	0	0	0	0	0	0	0	0	0	0	0	0	0	0	1	0	0	0	0	0	0		
	Green(2)	0	0	0	0	0	0	0	0	0	0	0	0	0	0	1	0	0	0	0	0	0	0		
	⋮	⋮	⋮	⋮	⋮	⋮	⋮	⋮	⋮	⋮	⋮	⋮	⋮	⋮	⋮	⋮	⋮	⋮	⋮	⋮	⋮	⋮	⋮		
	⋮	⋮	⋮	⋮	⋮	⋮	⋮	⋮	⋮	⋮	⋮	⋮	⋮	⋮	⋮	⋮	⋮	⋮	⋮	⋮	⋮	⋮	⋮		
	Green(253)	0	0	0	0	0	0	0	0	1	1	1	1	1	1	0	1	0	0	0	0	0	0		
	Green(254)	0	0	0	0	0	0	0	0	1	1	1	1	1	1	1	0	0	0	0	0	0	0		
	Green(255)	0	0	0	0	0	0	0	0	1	1	1	1	1	1	1	1	0	0	0	0	0	0		
Gray Scale Of Blue	Blue(0) / Dark	0	0	0	0	0	0	0	0	0	0	0	0	0	0	0	0	0	0	0	0	0	0		
	Blue(1)	0	0	0	0	0	0	0	0	0	0	0	0	0	0	0	0	0	0	0	0	0	1		
	Blue(2)	0	0	0	0	0	0	0	0	0	0	0	0	0	0	0	0	0	0	0	0	0	1		
	⋮	⋮	⋮	⋮	⋮	⋮	⋮	⋮	⋮	⋮	⋮	⋮	⋮	⋮	⋮	⋮	⋮	⋮	⋮	⋮	⋮	⋮	⋮		
	⋮	⋮	⋮	⋮	⋮	⋮	⋮	⋮	⋮	⋮	⋮	⋮	⋮	⋮	⋮	⋮	⋮	⋮	⋮	⋮	⋮	⋮	⋮		
	Blue(253)	0	0	0	0	0	0	0	0	0	0	0	0	0	0	0	1	1	1	1	1	1	0		
	Blue(254)	0	0	0	0	0	0	0	0	0	0	0	0	0	0	0	1	1	1	1	1	1	1		
	Blue(255)	0	0	0	0	0	0	0	0	0	0	0	0	0	0	0	1	1	1	1	1	1	1		

Note (1) 0: Low Level Voltage, 1: High Level Voltage

7. BLOCK DIAGRAM

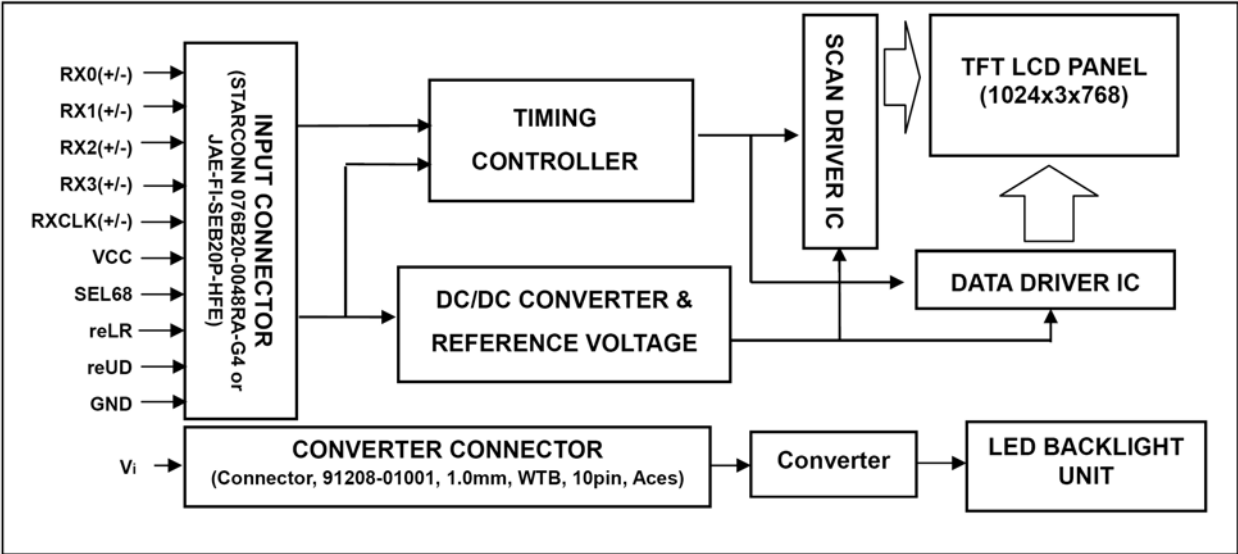

8.INTERFACE TIMING

8.1 Input signal timing specifications

The input signal timing specifications are shown as the following table and timing diagram.

Signal	Item	Symbol	Min.	Typ.	Max.	Unit	Note
DCLK	Frequency	Fc	57.5	64.9	74.4	MHz	
Vertical Active Display Term	Total	Tv	774	806	848	Th	Tv=Tvd+Tvb
	Display	Tvd	-	768	-	Th	-
	Blank	Tvb	6	38	80	Th	-
Horizontal Active Display Term	Total	Th	1240	1344	1464	Tc	Th=Thd+Thb
	Display	Thd	-	1024	-	Tc	-
	Blank	Thb	216	320	440	Tc	-

Note (1) Since this assembly is operated in DE only mode, Hsync and Vsync input signals should be set to low logic level. Otherwise, this assembly would operate abnormally.

(2) Frame rate is 60Hz

INPUT SIGNAL TIMING DIAGRAM

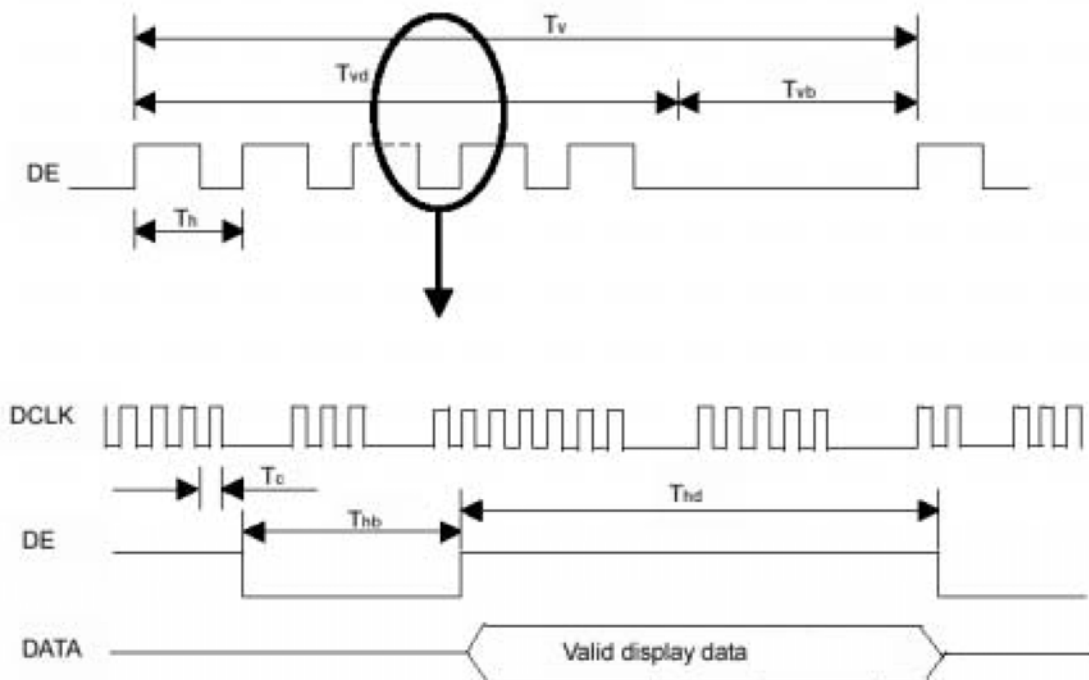

8.2 Power ON/OFF Sequence

To prevent a latch-up or DC operation of LCD assembly, the power on/off sequence should be as the diagram below.

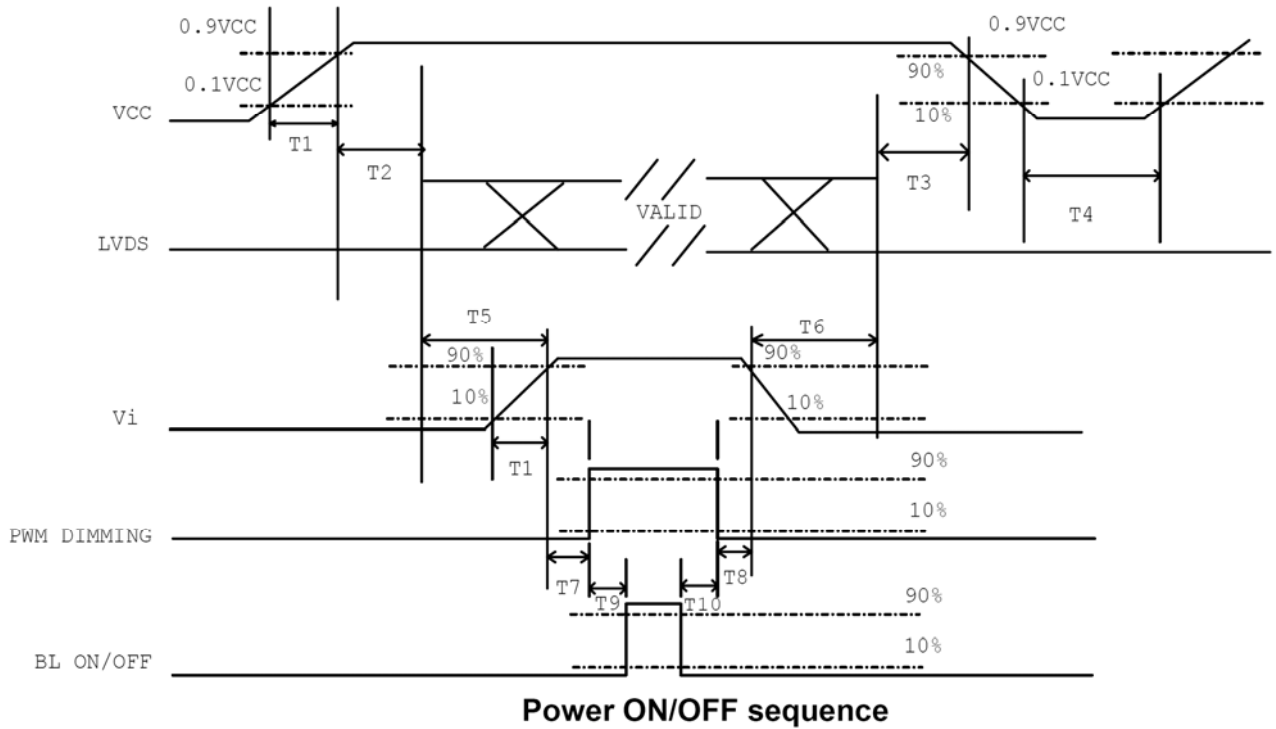

Power ON/OFF sequence

Note (1) Please avoid floating state of interface signal at invalid period.

Note (2) When the interface signal is invalid, be sure to pull down the power supply of LCD VCC to 0 V.

Note (3) The Backlight converter power must be turned on after the power supply for the logic and the interface signal is valid. The Backlight converter power must be turned off before the power supply for the logic and the interface signal is invalid.

Parameter	Value			Units
	Min	Typ	Max	
T1	0.5	-	10	ms
T2	0	-	50	ms
T3	0	-	50	ms
T4	500	-	-	ms
T5	200	-	-	ms
T6	200	-	-	ms
T7	10	-	-	ms
T8	10	-	-	ms
T9	10	-	-	ms
T10	0	-	-	ms

8.3 The Input Data Format

SEL68 = "Low" or "NC" for 6 bits LVDS Input

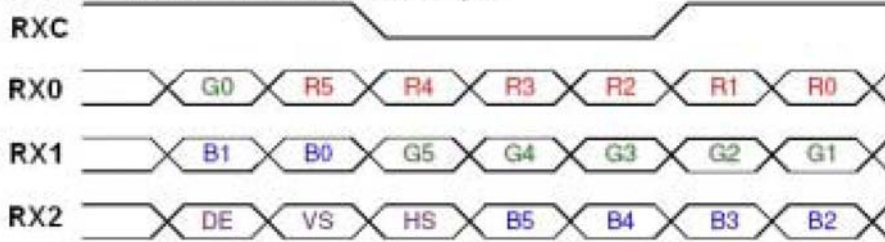

SEL68 = "High" for 8 bits LVDS Input

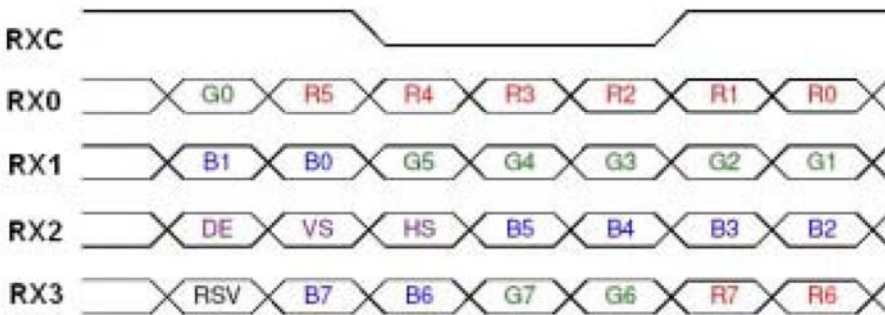

Note (1) R/G/B data 7: MSB, R/G/B data 0: LSB

Note (2) Please follow PSWG

Signal Name	Description	Remark
R7	Red Data 7 (MSB)	Red-pixel Data Each red pixel's brightness data consists of these 8 bits pixel data.
R6	Red Data 6	
R5	Red Data 5	
R4	Red Data 4	
R3	Red Data 3	
R2	Red Data 2	
R1	Red Data 1	
R0	Red Data 0 (LSB)	
G7	Green Data 7 (MSB)	Green-pixel Data Each green pixel's brightness data consists of these 8 bits pixel data.
G6	GreenData 6	
G5	GreenData 5	
G4	GreenData 4	
G3	GreenData 3	
G2	GreenData 2	
G1	GreenData 1	
G0	GreenData 0 (LSB)	
B7	Blue Data 7 (MSB)	Blue-pixel Data Each blue pixel's brightness data consists of these 8 bits pixel data.
B6	Blue Data 6	
B5	Blue Data 5	
B4	Blue Data 4	
B3	Blue Data 3	
B2	Blue Data 2	
B1	Blue Data 1	
B0	Blue Data 0 (LSB)	
RXCLKIN+	LVDS Clock Input	
RXCLKIN-		
DE	Display Enable	
VS	Vertical Sync	
HS	Horizontal Sync	

Note (3) Output signals from any system shall be low or Hi-Z state when VCC is off.

8.4 Scanning Direction

The following figures show the image see from the front view. The arrow indicates the direction of scan.

Fig.1 Normal Scan

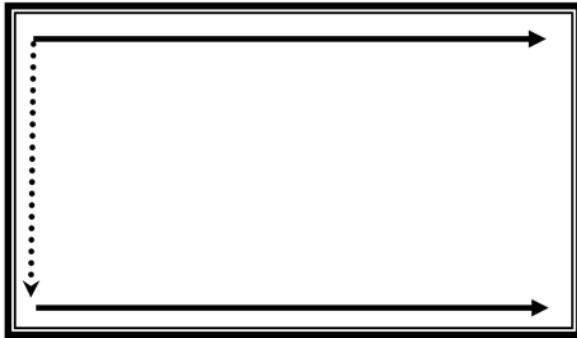

Fig.2 Reverse Scan

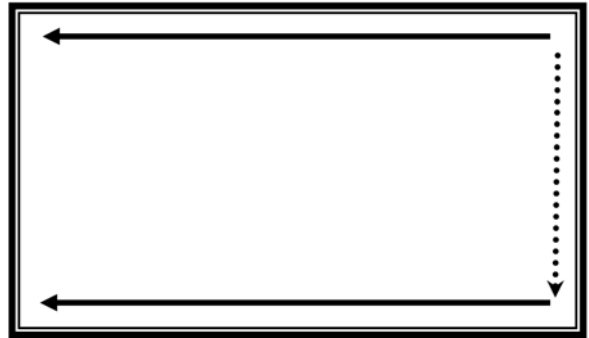

Fig.3 Reverse Scan

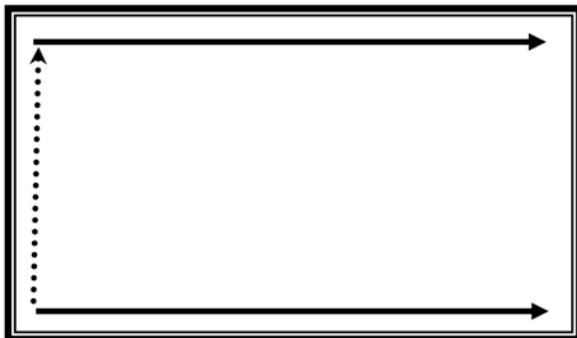

Fig.4 Reverse Scan

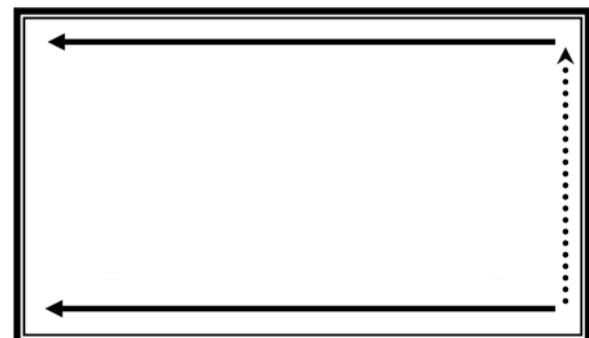

Fig. 1 Normal scan (pin 17, reLR = Low or NC, pin 18, reUD = Low or NC)

Fig. 2 Reverse scan (pin 17, reLR = High, pin 18, reUD = Low or NC)

Fig. 3 Reverse scan (pin 17, reLR = Low or NC, pin 18, reUD = High)

Fig. 4 Reverse scan (pin 17, reLR = High, pin 18, reUD = High)

9.RELIABILITY TEST CONDITIONS

Test Item	Test Condition	Note
High Temperature Storage Test	85°C, 240 hours	(1)(2)
Low Temperature Storage Test	-40°C, 240 hours	
Thermal Shock Storage Test	-30°C, 0.5hour \longleftrightarrow 80°C, 0.5hour; 1hour/cycle,100cycles	
High Temperature Operation Test	80°C, 240 hours	
Low Temperature Operation Test	-30°C, 240 hours	
High Temperature & High Humidity Operation Test	60°C, 90%RH, 240hours	
Shock (Non-Operating)	200G, 2ms, half sine wave, 1 time for $\pm X$, $\pm Y$, $\pm Z$.	(3)
Vibration (Non-Operating)	1.5G, 10 ~ 300 Hz, 10min/cycle, 3 cycles each X, Y, Z	(3)

Note (1) There should be no condensation on the surface of panel during test.

Note (2) Temperature of panel display surface area should be 90 °C Max.

Note (3) At testing Vibration and Shock, the fixture in holding the module has to be hard and rigid enough so that the module would not be twisted or bent by the fixture.

Note (4) In the standard conditions, there is no function failure issue occurred. All the cosmetic specification is judged before reliability test.

10. HANDLING & CAUTIONS

10.1 Cautions when taking out the module

Pick the pouch only, when taking out module from a shipping package.

10.2 Cautions for handling the module

10.2.1 As the electrostatic discharges may break the LCD module, handle the LCD module with care. Peel a protection sheet off from the LCD panel surface as slowly as possible.

10.2.2 As the LCD panel and backlight element are made from fragile glass material, impulse and pressure to the LCD module should be avoided.

10.2.3 As the surface of the polarizer is very soft and easily scratched, use a soft dry cloth without chemicals for cleaning.

10.2.4 Do not pull the interface connector in or out while the LCD module is operating.

10.2.5 Put the module display side down on a flat horizontal plane.

10.2.6 Handle connectors and cables with care.

10.3 Cautions for the operation

10.3.1 When the module is operating, do not lose MCLK, DE signals. If any one of these signals were lost, the LCD panel would be damaged.

10.3.2 Obey the supply voltage sequence. If wrong sequence were applied, the module would be damaged.

10.4 Cautions for the atmosphere

10.4.1 Dewdrop atmosphere should be avoided.

10.4.2 Do not store and/or operate the LCD module in a high temperature and/or humidity atmosphere. Storage in an electro-conductive polymer-packing pouch and under relatively low temperature atmosphere is recommended.

10.5 Cautions for the module characteristics

10.5.1 Do not apply fixed pattern data signal to the LCD module at product aging.

10.5.2 Applying fixed pattern for a long time may cause image sticking.

10.6 Other cautions

10.6.1 Do not disassemble and/or re-assemble LCD module.

10.6.2 Do not re-adjust variable resistor or switch etc.

10.6.3 When returning the module for repair or etc, please pack the module not to be broken. We recommend using the original shipping packages.

10.6.4 AMIPRE will provide one year warrantee for all products and three months warrantee for all repairing products.

11. OUTLINE DIMENSION

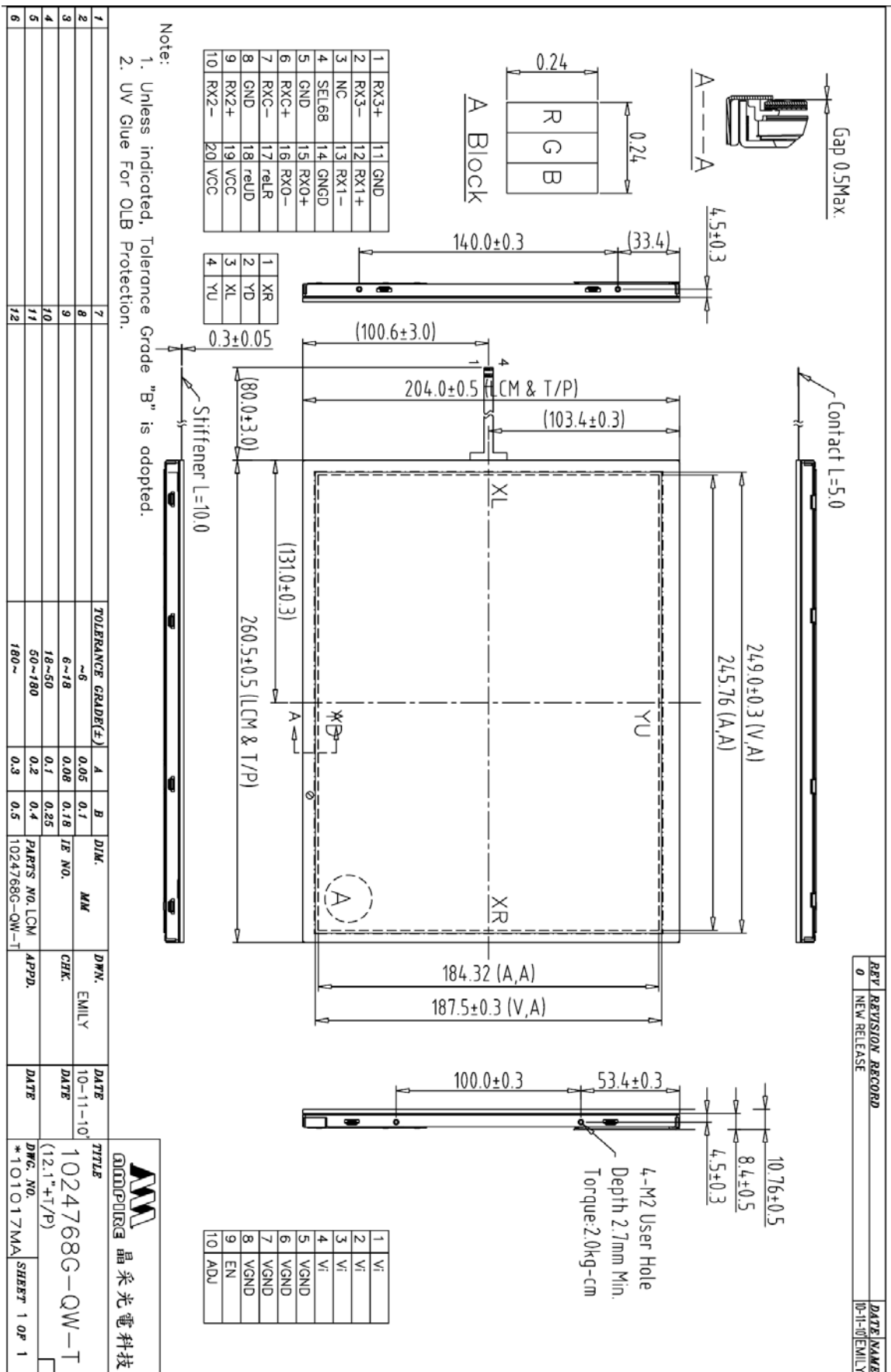

REV	REVISION RECORD	DATE	NAME
0	NEW RELEASE	10-11-10	EMILY

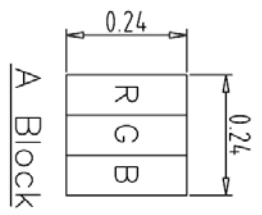

1	RX3+	11	GND
2	RX3-	12	RX1+
3	NC	13	RX1-
4	SEL68	14	GNGD
5	GND	15	RX0+
6	RXC+	16	RX0-
7	RXC-	17	reLR
8	GND	18	reUD
9	RX2+	19	VCC
10	RX2-	20	VCC

1	XR
2	YD
3	XL
4	YU

Note:
 1. Unless indicated, Tolerance Grade "B" is adopted.
 2. UV Glue For OLB Protection.

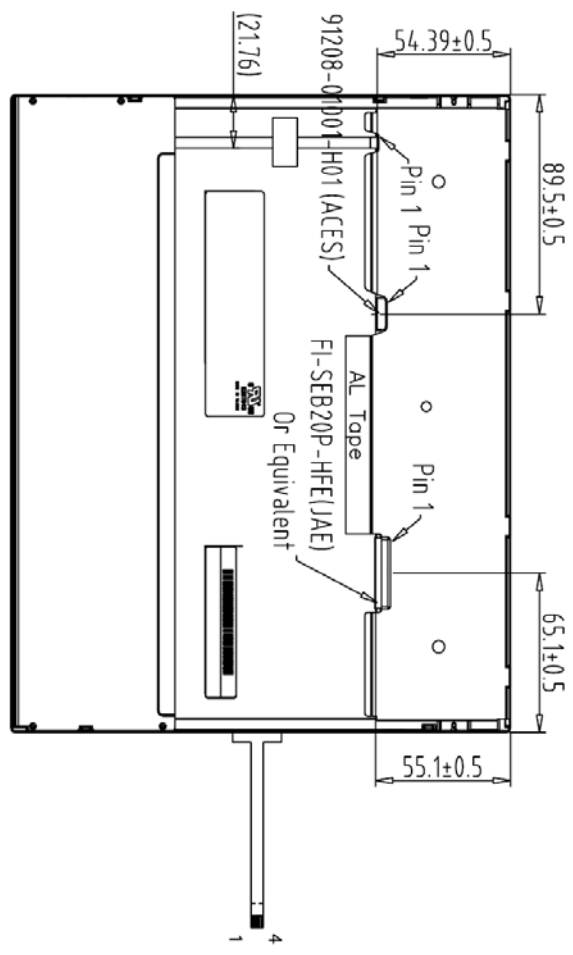

Back View

1	Vf
2	Vf
3	Vf
4	Vf
5	VGND
6	VGND
7	VGND
8	VGND
9	EN
10	ADJ

1		7		TOLERANCE GRADE(±)	A	B	DIM.	MM	DWN.	EMILY	DATE	10-11-10	TITLE	1024768G-QW-T
2		8		~6	0.05	0.1	IE NO.		CHK.		DATE		DWG. NO.	(12.1"+T/P)
3		9		6~18	0.08	0.18							DWG. NO.	*101018MA
4		10		18~50	0.1	0.25							SHEET	1 OF 1
5		11		50~180	0.2	0.4	PARTS NO.	LCM-1	APPD.					
6		12		180~	0.3	0.5		1024768G-QW-T						

